

**FLEETWOOD FOLDING TRAILERS, INC.
INSTALLATION INSTRUCTIONS**

1968-568
Revised July 2005

MODEL NUMBER: 4768-6931 - ROTO MOLDED GAS BOTTLE COVER

This kit for use on grey roto molded front storage box models only.

This package contains:

4	-	1187B161	1/4 - 20 x 5/8 Phillips machine screw
4	-	4732-118	plastic grommet
2	-	4747C923	rivet
2	-	4747-255	rivet
1	-	4759-029	LP cover
1	-	4759-033	LP bottom keeper angle
1	-	4759-032	LP cover top keeper
2	-	4733-420	#10 x 1 1/2" Phillips tek screw
2	-	4751-343	nylon spacer

IMPORTANT NOTICE

These instructions are for the use of qualified individuals specifically trained and experienced in the installation of this type equipment and related system components. Installation and service personnel are required by some states to be licensed. Persons not qualified shall not attempt to install this equipment nor interpret the instructions.

INSTRUCTIONS:

1. Locate the nylon spacers on top of each tongue bar approximately 1/2 in from the inside edge. Also place them so that each one is about even with the outer edge of the front body panel. See Photo 1. Mark the location and use a 1/8" drill bit to pre-drill the attachment holes. Attach each nylon spacer using the 1 1/2" self tapping screw (4733-420) provided.

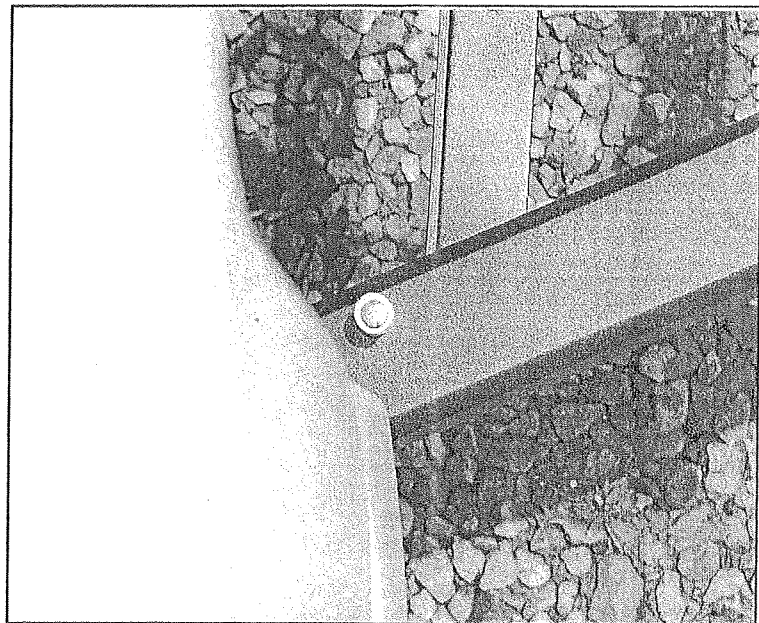

PHOTO 1

2. Rivet the bottom zee keeper angle (4759-033) to the vertical leg of the gas bottle angle nearest to the hitch with two rivets (4747C923) provided.

NOTE: The zee angle leg with the plastic grommet installed will point vertically. See figure 1.

3. Attach the top keeper to the cover using two 1/4 - 20 x 5/8 PHMS (1121C161) provided.

NOTE: Ensure short end of top keeper mounting bracket is oriented as shown in figure 1 toward the ABS front body panel.

4. Screw the LP cover to the bottom zee keeper angle using two 1/4 - 20 x 5/8 PHMS provided. The cover will now be sitting on the gas bottle angles.
5. Again, with the cover attached at the bottom front, and using the top keeper as the template, reach through the LP lid opening in the cover to mark one hole on the top surface of the front body panel recess 1" in from the front. See figure 2.
6. Remove the LP cover and drill one 0.199 hole using a #8 drill bit at the one location marked in step 5.
7. Remove the top keeper from the cover and place the strip of butyl tape on the top edge of top keeper. Rivet the top keeper at the hole drilled in step 6 at the top surface of the body panel recess using one 4747-255 rivet.

NOTE: Refer to figure 1 for proper orientation of the top keeper bracket prior to riveting.

8. With the top keeper attached by one rivet, drill the second hole using the top keeper as the template and then rivet it in place.
9. Reattach the cover using the four 1/4 - 20 x 5/8 PHMS and the LP lid using two thumbscrews.

FIGURE 1

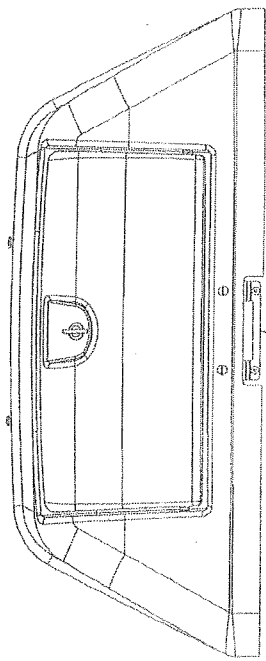

MARK AND DRILL 3/16" HOLE X2 TO UNDERSIDE
OF RECEIVED AREA ON BODY PANEL
NOTE: USE MOUNTING BRACKET AS TEMPLATE
TO MARK HOLES
ADD BUTYL TAPE TOP EDGE PRIOR TO FINAL
ATTACHMENT.

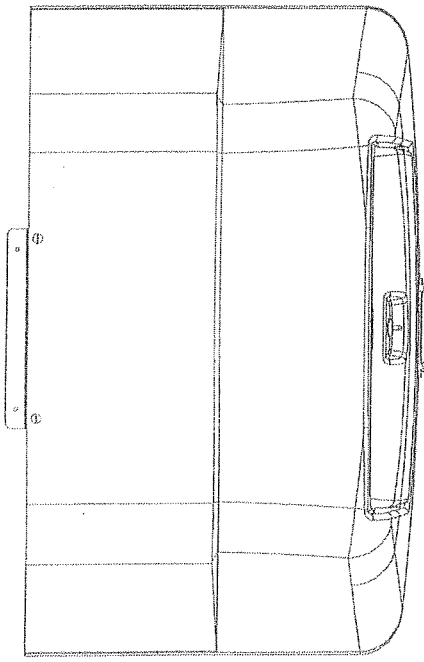

TOP KEEPER MOUNTING BRACKET
MUST BE ORIENTED UNDER END
OVER AS SHOWN (SHORT END
OF ANGLE BRACKETS TOWARD FRONT
OF BODY PANEL)

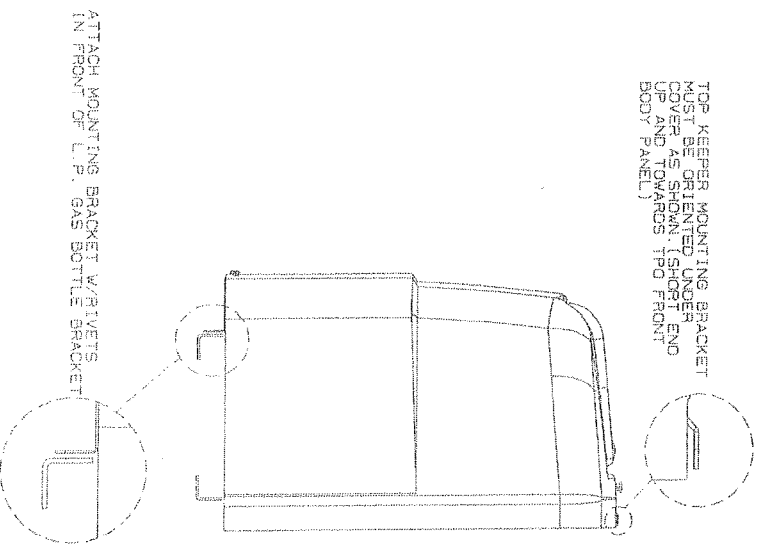

ATTACH MOUNTING BRACKET W/RIVETS
IN FRONT OF L.P. GAS BOTTLE BRACKET