

What You Should Know About Your L.P. Gas System and Its Proper Care

Printed and distributed in the interest of safety by the
nation's leading manufacturers of L.P. gas regulators.

Marshall

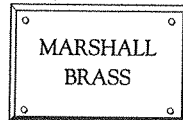

MARSHALL BRASS & MARSHALL GAS CONTROLS
DIVISIONS OF S.H. LEGGITT COMPANY

(800) 877-2495
Fax (512) 396-2217

1000 Civic Center Drive
San Marcos, TX 78666

Typical L.P. Gas Hook Ups

Two Cylinder Hook Up

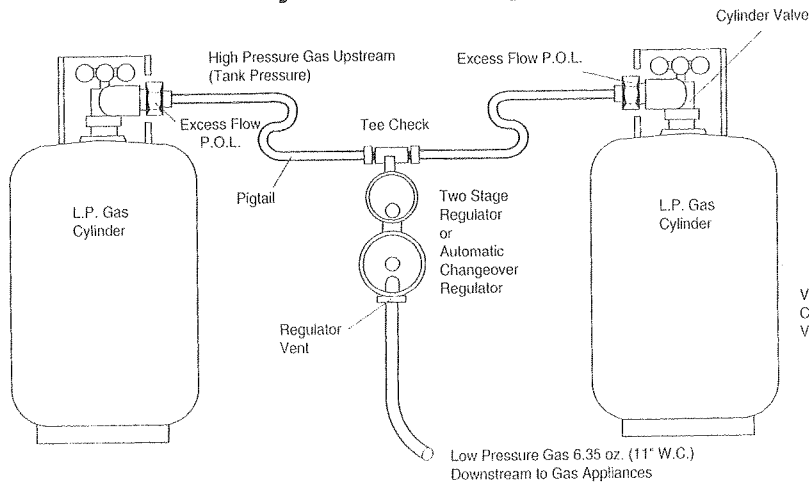

A.S.M.E. Tank or Single Tank Hook Up

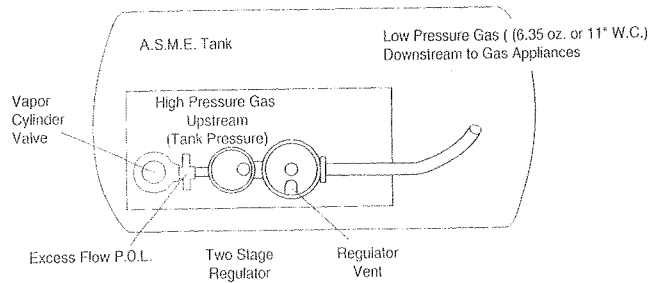

The P.O.L.

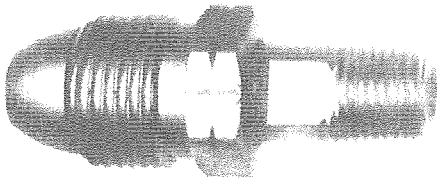

P.O.L. Adapter

The P.O.L. (presto-lite) adapter, sometimes called a spud and nut, is required to convey the L.P. gas to the regulator. With a single tank the P.O.L. is inserted directly into the regulator inlet. With a two-tank hookup, two flexible pigtails with an excess flow P.O.L. on one end and an appropriate fitting on the other end are used.

Your P.O.L. may be equipped with an excess flow device. If you are the owner of a recreational vehicle manufactured after December 1977, your vehicle probably has one. You can quickly check by looking at the inlet end. If it has internal parts instead of a free-flow hole, it is an excess flow P.O.L.

The excess flow P.O.L. is intended to restrict the flow of escaping gas in the event the

regulator is broken off at the P.O.L. However, it is not designed to detect a leak or totally shut off the system in the event of a leak or failure of the regulator. Under certain conditions, an excess flow P.O.L. could cause a restriction in the supply of fuel to appliances. To eliminate this problem, the following procedures should be followed each time the cylinder is opened or restricted fuel flow is evident:

1. Be sure all appliances, including their pilot lights, are off and no gas is flowing from the system.
2. Open valve of L.P. tank slowly.
DO NOT SNAP OPEN.
3. Be sure all connections have been tested with a soapy solution (dishwashing liquid) or leak detector to assure that the system is leak free.
4. Wait at least 15 seconds before lighting appliances.

The P.O.L. has a left-hand (counter-clockwise) thread. Turn it to the left to tighten, to the right to loosen. Since it is a brass-to-brass seal, it is not necessary to use pipe dope. However, be sure to test all connections with a soapy solution before lighting any appliances.

The Tee Check

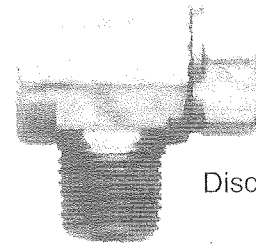

Disc Tee Check

The tee check allows you to run two L.P. gas cylinders through one regulator by using a pigtail from each cylinder valve to the tee check. This converts your regulator to a manual changeover. That is, you open the valve on the cylinder and use it until empty or almost empty, then open the valve on the reserve cylinder, close the valve on the first cylinder, disconnect it and have it refilled. A disc check built into the tee will prevent gas escaping when the empty cylinder is disconnected.

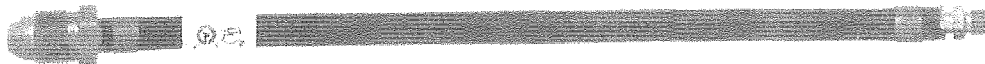

Flexible Excess Flow Pigtail

Regulators

Marshall Gas Controls
290 Two Stage Regulator

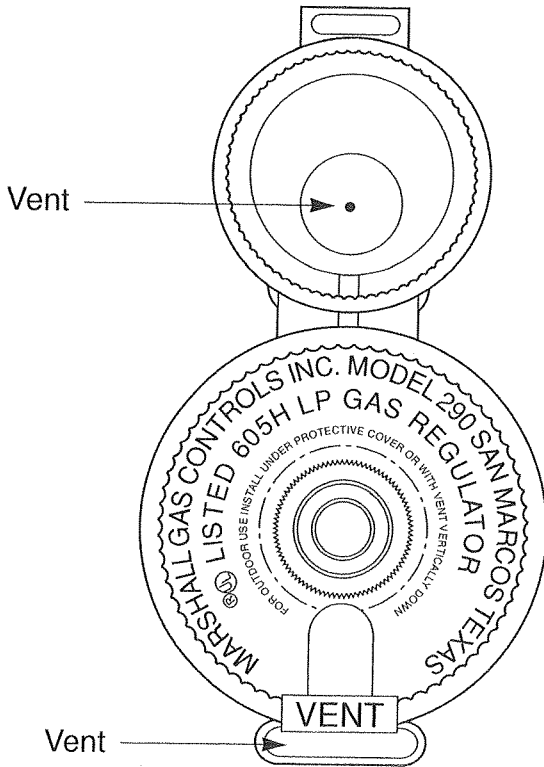

Marshall Gas Controls
254 Changeover Regulator

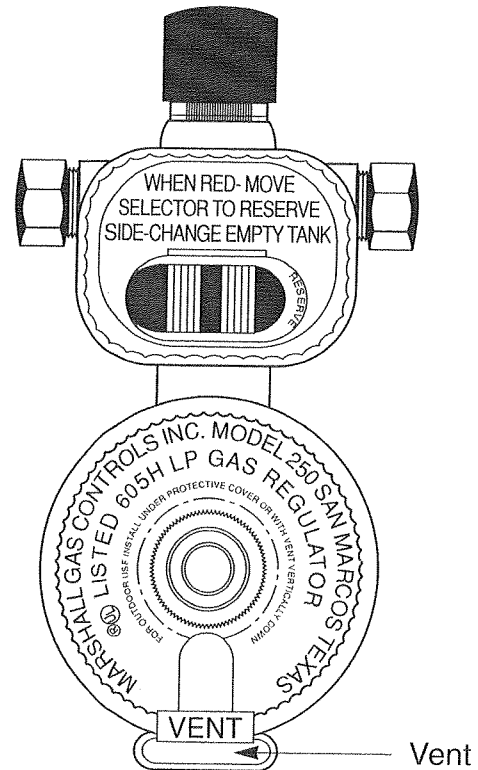

HOW SHOULD YOUR REGULATOR BE MOUNTED?

The regulator will function regardless of the position in which it is mounted. However, ANSI A119.2, NFPA 501C Recreational Vehicles Code at 2-2.7.6 provides in part, "The regulator(s) shall be mounted only in a position (with the vent pointed) downward within 45 degrees of vertical and the diaphragm area being drained." (Emphasis added). It is important to install the regulator in a position in which the cover cannot possibly become a receptacle for water or other foreign material.

WHAT IS A TWO-STAGE REGULATOR?

The Marshall 290 Series Integral Two-Stage Regulator is a high pressure regulator combined with a second-stage regulator. The high pressure regulator reduces the full cylinder pressure within 10-13 psig range. The second-stage then reduces this inlet pressure down to 11 inches of water column outlet pressure (0.4 psig).

With single-stage regulation, the regulator functions under extreme variations of inlet pressure caused by the changes in outside temperature. As a result of these variations in

inlet pressure, minor variations in outlet pressure are possible. Two-stage regulation results in a consistent inlet pressure to the second-stage, thereby minimizing minor outlet pressure variations from the second-stage regulator.

Additionally, moisture caused by water in the L.P. gas or condensation can result in ice forming at the orifice. This can result in a gas stoppage. The possibility of freeze up is greatly reduced with two-stage L.P. gas regulation.

WHAT IS A CHANGOVER REGULATOR?

The Marshall 254 Two Stage Regulator offers the convenience of automatic changeover from empty to full gas cylinder, plus the additional efficiency of two stage pressure regulation. The top portion of the changeover is a dual high pressure regulator, which reduces bottle pressure to approximately 10 to 15 psig and sends it to the second stage low pressure regulator, which completes the regulation process by reducing the 15 psig inlet pressure down to 11 inches of water column (0.4 psig) outlet pressure.

There should be propane in both cylinders to start. Slide the black bar on the top of the regulator towards the cylinder you want to use first. This will be the "supply" cylinder and the

other will be the "reserve" cylinder. Slowly open both cylinder valves. The full-empty indicator on the top of the regulator will turn bright green. The indicator color will stay green as long as there is fuel coming from the "supply" cylinder. When the "supply" cylinder empties, the regulator will automatically switch over to the "reserve" cylinder providing an uninterrupted fuel flow to the system. When it switches over, the full-empty indicator color changes from green to a bright orange. This orange color signals that one cylinder is completely empty and needs to be filled. To remove the empty cylinder, slide the black bar all the way over towards the other cylinder. The full-empty indicator will turn to green and the other cylinder becomes the "supply" cylinder. Next, shut off the cylinder valve on the empty cylinder. Now it's safe to disconnect the cylinder and have it refilled. After filling, reconnect the pigtail and slowly open the cylinder valve. The full cylinder now becomes the "reserve" cylinder.

THE COVER

U.L. 144 requires a cover for certain types of regulators. However, it is a good idea for all regulators to be protected from all elements by a cover whether it is required or not.

The Flexible Hoses



Original Equipment Flexible Hoses are manufactured to strict standards and are listed by Underwriters Laboratories and/or Canadian Gas Association. High Pressure Hoses (Pigtails) are assembled from hose which has a rating of 350 P.S.I.G. working pressure and a burst rating of 1750 P.S.I. High Pressure Hoses must withstand an axial pull test of 400 lbf. The Low Pressure Hose has a rating of 1 P.S.I., however, the hose has a working pressure rating of 125 P.S.I. and a burst strength of 600 P.S.I., and must withstand a 200 lbf. pull test.

The concerns of Rubber Hose are sunlight (ultra violet rays) and ozone. Consequently, your hoses should be checked periodically for signs of aging. The average life of L.P. Hoses depends on the care and protection given them. For your protection, check your hoses before each season's use and each time your L.P. Gas tank(s) are refilled for signs of deterioration or weather cracking. Protect the hoses from direct sun light whenever possible and be sure when replacing your hose that you purchase properly rated, U.L. or C.G.A. listed replacement hose assemblies.

HOW TO KEEP YOUR REGULATOR OPERATING EFFICIENTLY & SAFELY

Your regulator is equipped with a vent (see preceding page) which allows the diaphragm to "breathe." That is, the diaphragm of the regulator moves down and draws air into the bonnet or adjustment spring housing. When the diaphragm moves up, air is expelled through the vent. In the event that excess pressure builds up in the lower housing or body of the regulator, a relief mechanism vents it to the atmosphere. So, it is imperative to check the vent frequently to be sure it is clean and free of water, corrosion or obstruction,

as clogging is the most common cause of regulator malfunction. Great care has been taken in the manufacture of your regulator and it has been thoroughly tested and U.L. listed. However, even a small piece of dirt, corrosion, pipe dope or other foreign matter which finds its way into the regulator can result in higher than normal pressure (high lockup) and/or loss of fuel.

If the vent does become clogged it can easily be cleaned with a toothbrush. In addition, your regulator should be checked periodically by a competent L.P. serviceman to be sure it is properly adjusted and in safe working condition. By following these simple precautions your regulator will give you years of trouble-free service.

WHAT IS REGULATOR FREEZE UP?

A regulator does not freeze, nor will L.P. gas under normal atmospheric conditions. However, as the gas passes through the regulator it expands and cools and moisture in the gas or in the regulator will turn to ice. This ice can build up and totally or partially block the orifice and thus partially or totally block the fuel supply. There are a number of things you can do to prevent this type of freeze up:

1. Be sure your L.P. cylinder is totally free of moisture before it is filled.
2. Be sure your cylinder is not overfilled. This is particularly important if you have a permanently mounted A.S.M.E. tank.
3. Keep the valves on empty cylinders closed.

4. Have your L.P. dealer purge the cylinder if freeze up occurs.
5. Have your L.P. dealer inject methyl alcohol in your cylinder.
6. Install a two-stage regulator if your system has only a single-stage regulator.



MARSHALL BRASS & MARSHALL GAS CONTROLS
DIVISIONS OF S.H. LEGGITT COMPANY

(800) 877-2495
Fax (512) 396-2217

1000 Civic Center Drive
San Marcos, TX 78666