

# UPRIGHT ROOF RACK

64720

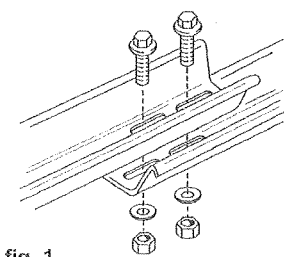

fig. 1

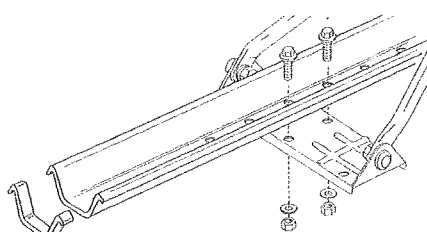

fig. 2

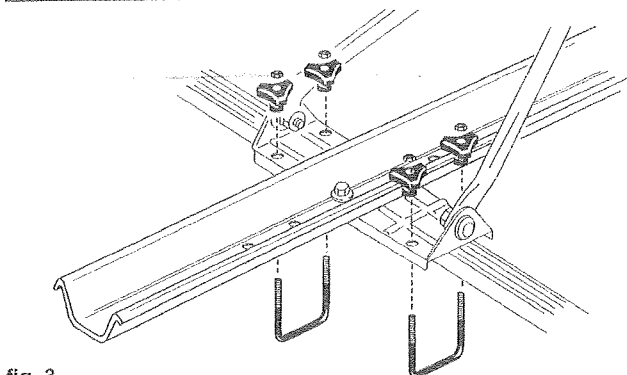

fig. 3

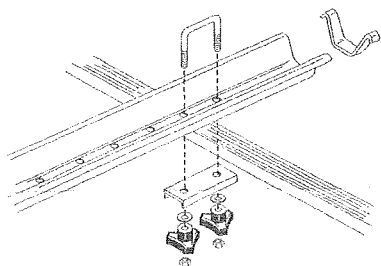

fig. 4

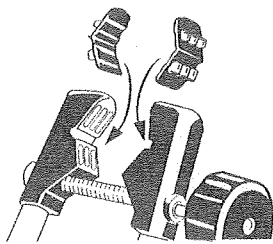

fig. 5

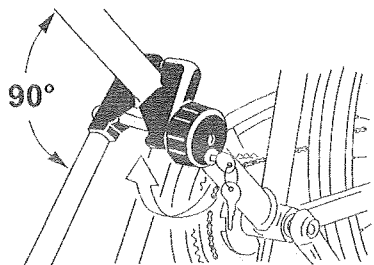

fig. 6

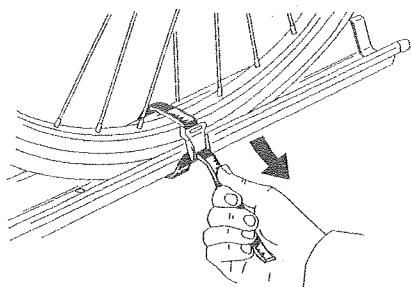
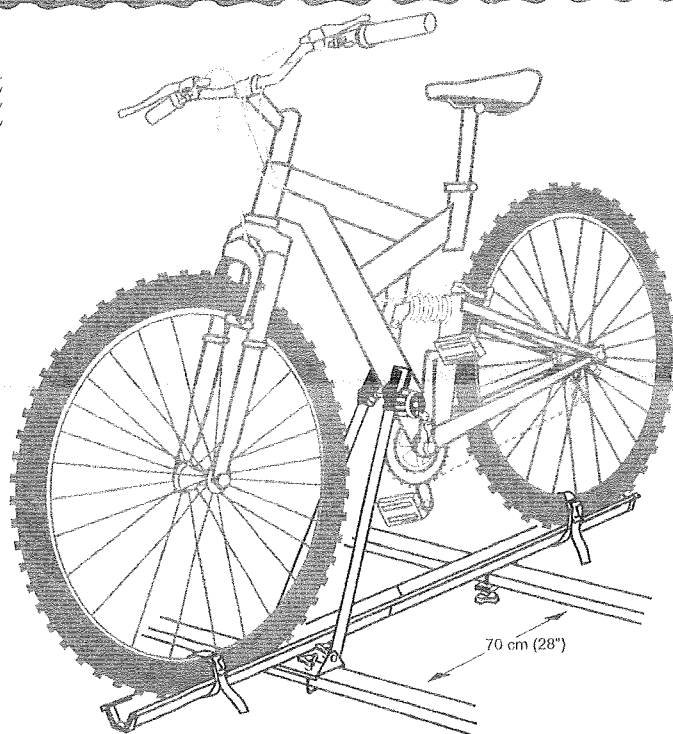

fig. 7



## Instructions:

Assemble the wheel trays using the two nuts, bolts and washers (fig. 1). Install the plastic tray end caps (fig. 2).

Attach the bike support arm bracket to the front roof bar using the "U" bolts, nuts and plastic knobs provided (fig. 3). Attach the rear wheel tray using the "U" bolt and bracket (fig. 4). There are two different sizes of "U" bolts. Depending on the width of the roof bar will determine which "U" bolts are to be used.

**NOTE:** It is important that the bike is equally spaced on the wheel tray. If not then adjust accordingly. The distance between the roof bars should not be less than 28" or 70 cm. Check all nuts, bolts and knobs periodically to insure they are tight.

## Installing Bikes

Place your bike into position on the wheel tray and attach the bike clamp jaw to the down tube (fig. 5). Tighten the knob firmly. **NOTE:** The angle between the down tube on the bike and the support arm should be approximately 90 degrees. **NOTE:** The clamp jaw knob should be checked regularly to insure it is tight. Secure the wheels with the supplied wheel straps, and insure they are tight and that the webbing is lace through the buckle.

## Important notes

- The rack is supplied with a locking jaw knob. This is not a theft preventing device and extra security is recommended if the bikes are left unattended.
- Extra accessories such as child seats, baskets and bike covers should not be used due to the increase in wind resistance. This could cause damage to the rack, bikes or vehicle.
- Carrying items on the roof can adversely affect the handling of the vehicle, so drive slower, especially in cross winds.

**NOTE:** Don't forget that the bikes on the roof increase the height requirement. Be aware of entering underground parking or drive through fast food restaurants

Swagman cannot accept responsibility for damage caused by incorrect fitting.



Danik Industries Ltd.  
300 - 1880 Government St.  
Penticton, B.C. V2A 7J1

Phone (250) 490-8883  
Fax (250) 490-8885  
www.swagman.net