

**FLEETWOOD FOLDING TRAILERS, INC.**  
**INSTALLATION INSTRUCTIONS**

1968-473  
September 1996

**MODEL NUMBER: 4716-7911 BED REINFORCEMENT KIT**

**This kit contains:**

|   |   |          |                          |   |   |          |                   |
|---|---|----------|--------------------------|---|---|----------|-------------------|
| 2 | - | 4734G153 | L-bracket Bed Stop Angle | 8 | - | 1203-864 | Rivet             |
| 2 | - | 4755-251 | Reinforcement Angle      | 1 | - | 4753-999 | Solid Roll Pin    |
| 6 | - | 4733-411 | Tek Screw                | 1 | - | 1968-473 | Instruction Sheet |

**These instructions are designed to be used in conjunction with Product Enhancement Bulletin PE:96-3 for 1997 Sun Ridge model, Grand Tour series, folding trailers manufactured prior to September 4, 1996.**

1. Raise top assembly and secure in raised position.
2. Extend the front queen bed assembly and support using the two attached lower bed legs. Partially extend rear bed approximately two feet.
3. Referencing the illustration provided, place two bed reinforcement angles along the underside of the front bed frame (end closest to trailer). Orient the reinforcement angles as shown. Attach each reinforcement angle using two rivets and three Tek screws. The three Tek screws will be used to attach the top of the angle to the small bed frame flange. Slide bed into trailer far enough to allow access to install the three Tek screws along the top of the bed frame. The two rivets will secure the front of the angle to the bed frame facing. The rivets should be inserted from inside the trailer out through the bed frame and angle. It will be necessary to drill a 3/16" hole through the bed frame using the pre-drilled holes in the angle bracket as a template. Repeat procedure for second reinforcement angle.
4. From outside the trailer, remove one retaining screw and one flat washer from atop each curbside and roadside bed extension.
5. Slide the rear bed assembly inward. Lift the bed assembly up and over the roadside bed stop angle, located atop the rear body rail. As the bed assembly is lifted, ensure the rubber bed seal is not torn.
6. Referencing the illustration provided, attach the two L-bracket bed stop angles to the top of the rear body rail. It will be necessary to drill two 3/16" holes through the body rail using the bracket as a template. Attach the bracket using two rivets provided.
7. Pull the rear bed assembly back over the newly installed stop brackets and reinstall the retaining screw and flat washer removed in step 4.
8. Using a 1/8" punch, knock out the top roll pin in the curbside rear body rail. The roll pin will be the top roll pin closest to the doorway opening. Insert the new solid replacement roll pin in its place. Reference illustration provided.

**NOTE:** Solid roll pin is tapered. Ensure small end of roll pin is inserted first.

9. Function check bed to ensure smooth operation.

L-BRACKET STOP  
(ATTACH TO BODY  
RAIL)

2 1/4

1 1/4

8 1/2

7 1/2

BED REINFORCEMENT  
ANGLE (ATTACH TO  
INSIDE OF BED FRAME)

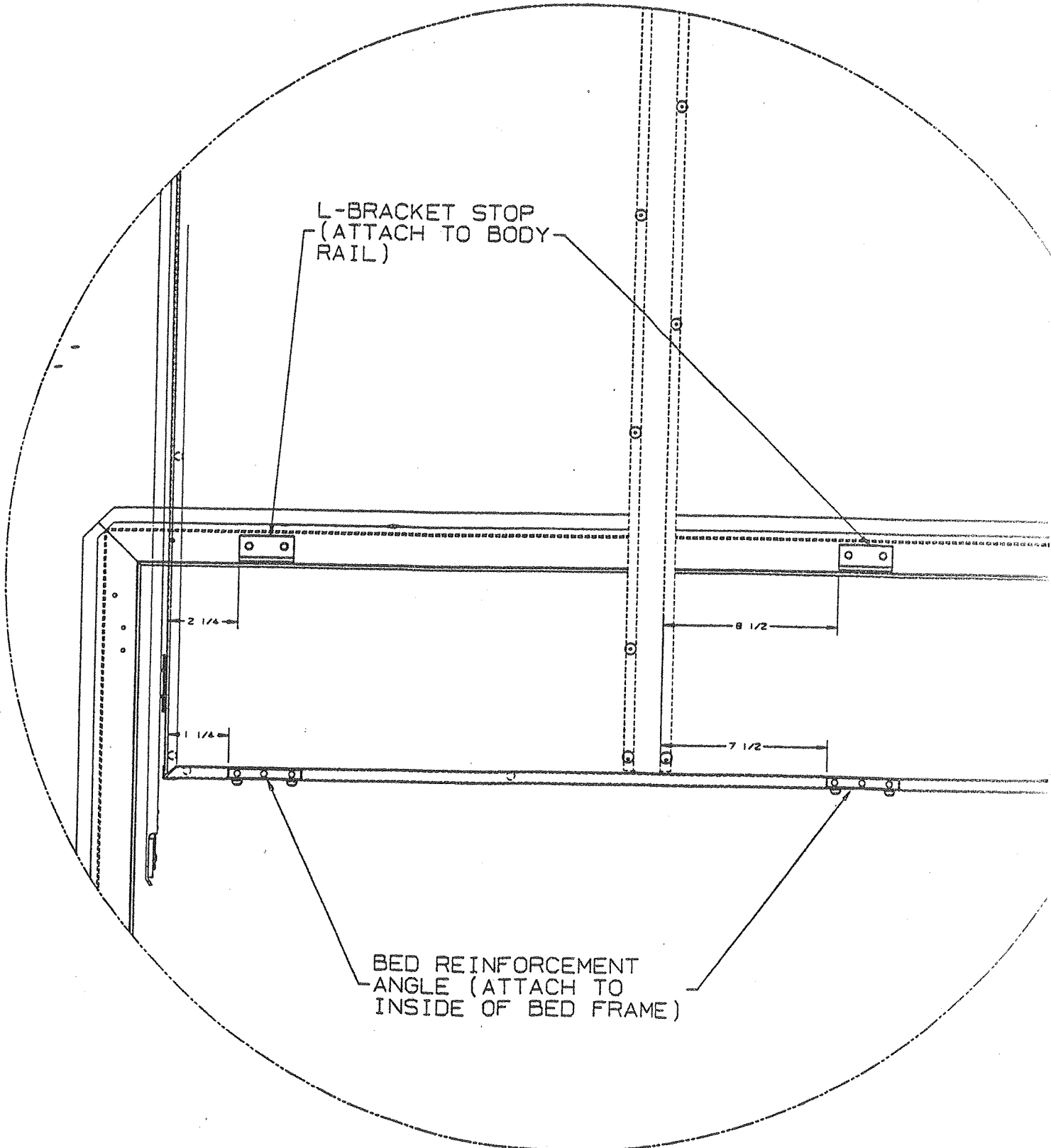

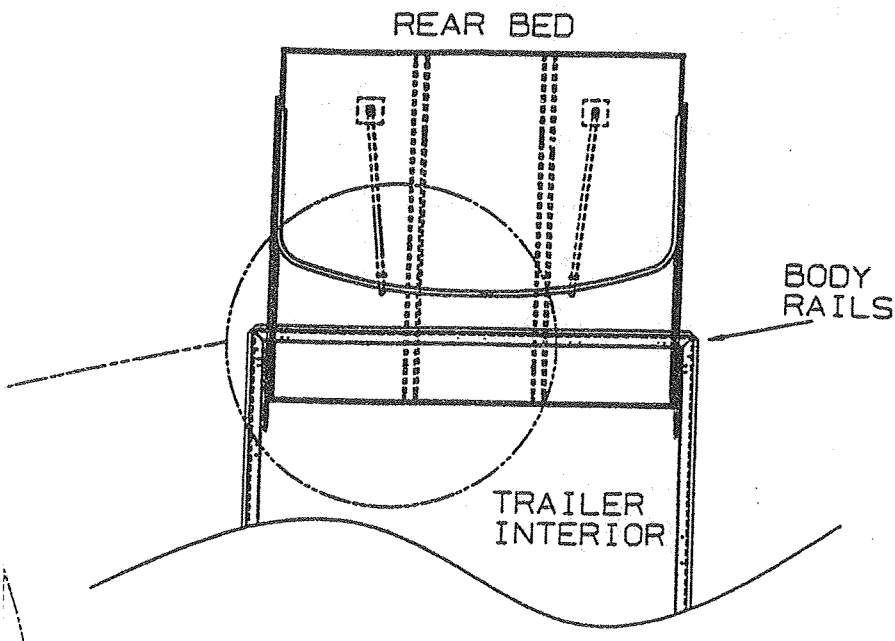

SEE REVERSE  
FOR FURTHER  
DRAWINGS

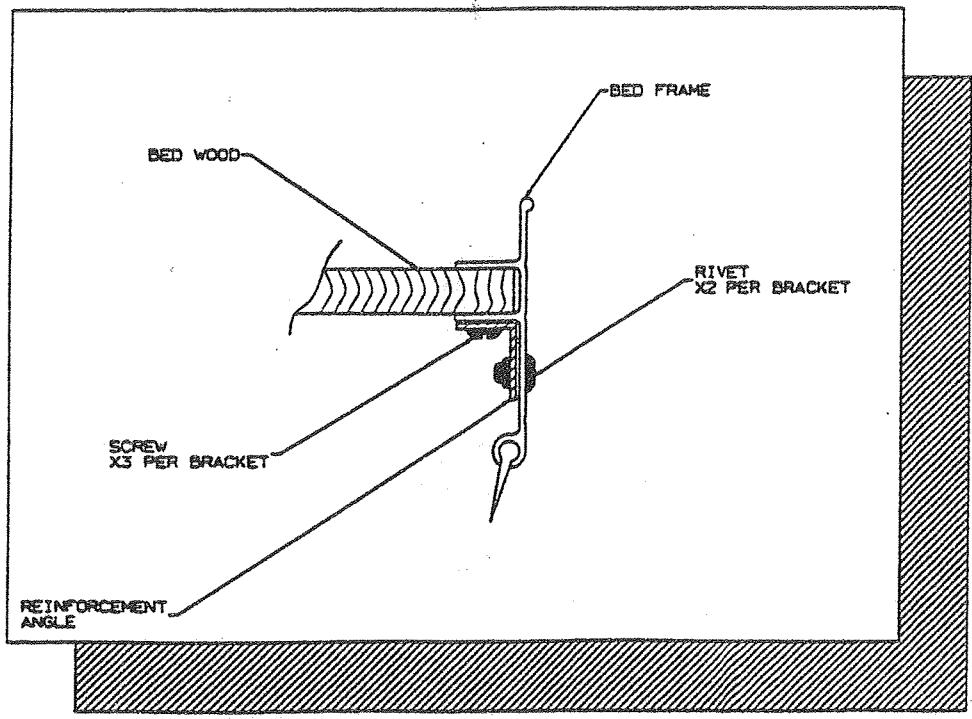
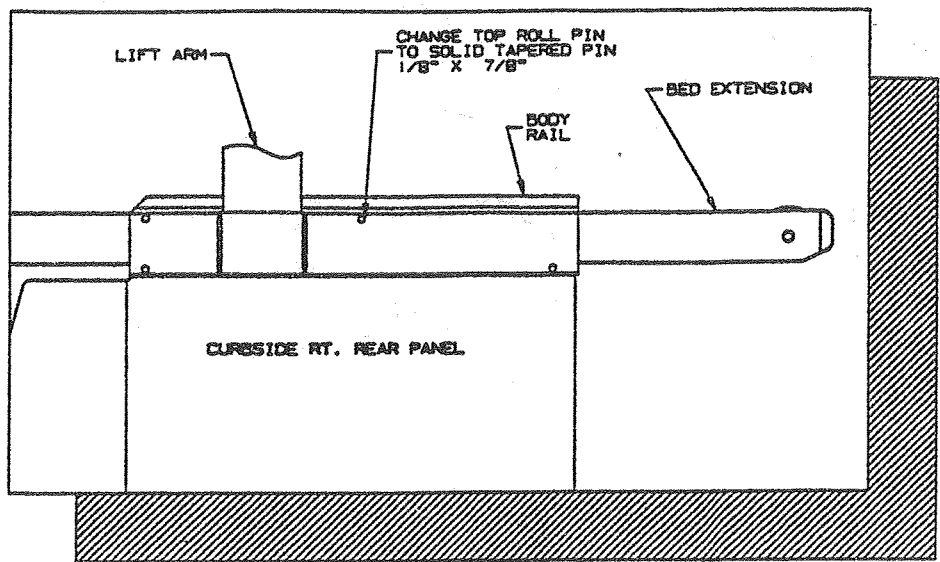

C:SRKIT