

Fleetwood



Folding Trailer Owner's Manual Grand Tour/Destiny Series



1999

TABLE OF CONTENTS

INTRODUCTION	1
IMPORTANT CONSUMER INFORMATION	1-2
PRE-TRIP PREPARATIONS	2-3
TOWING AND TRAILER WEIGHTS	3-7
Towing	3-4
Definitions of Trailer Weights	4-6
Approximate Weights of Common Accessories	6-7
SET-UP INSTRUCTIONS	7-18
Operating Lift System	8
Stabilizer Jacks	8-9
Beds	9-10
Glide-Out Compartment	10
Tent Enclosure	10-11
Swing-Level Galley	11
Bay Window	11
Hinged Galley/Stove Cabinet	11-12
Storage Shelf	12
Bed Bow Support	12
Dinette	12-13
Screen Door	13
Pull-Out Goucho Bed	13-14
Front Trunk Storage Area	14
Front Trunk Lighting	14
Shower	14-15
Inside Galley Stove Use	15-16
Outside Stove Use	16-18
TAKE-DOWN INSTRUCTIONS	18-22
GAS SYSTEM	22-26
Gas Bottle	23-24
Gas Bottle Regulator	24-25
L.P. Gas Regulator Freeze-Up	25
Propane Gas Leak Detector	26

WATER SYSTEMS	26-30
City Water	26-27
Water Tank	27
Sink Drain	27
12 Volt Electric Demand Water Pump	27-28
Hot Water System	28
Draining and Winterizing the Water System	29-30
TRACKING SYSTEM	30-33
Tires	30
How to Change a Flat	31
Brakes	31
Breakaway Switch	31-32
Ball Hitch and Coupler	32
Wheel Bearing Lubrication	32-33
LIFT SYSTEM MAINTENANCE/TOP ADJUSTMENT	33-34
TENT ENCLOSURE	34-35
Cleaning	34
Condensation Preventive Maintenance	34-35
Vinyl Bed Covers	35
Mattress Care	35
ROOF MOUNTED ACCESSORIES	35-36
ELECTRICAL	36-39
Converter	36-37
12 Volt Vehicular Electrical Circuit	37-38
110 Volt AC Power Supply	38
Wiring Color Codes	39
MAINTENANCE	40-42
WARRANTY	43-44
WEB SITE	www.foldingtrailers.com

INTRODUCTION

This manual contains important information regarding the safe operation and maintenance of your Fleetwood folding trailer. We urge you to read it carefully, understand all aspects of your trailer, and follow the recommendations to obtain the most trouble-free use of your recreational vehicle. In this manual, statements preceded by the following words are of special significance and we recommend that you take particular notice of these items when reading this manual:

WARNING means that there is a high possibility of serious personal injury to yourself and others if the warning is not complied with.

CAUTION means that there is the possibility of property damage.

IMPORTANT means that there is a possibility of damage to the trailer if instructions are not followed.

NOTE indicates points of particular interest for more efficient and convenient operation.

NOTE: The words "shall" or "must" indicate a requirement that is essential to satisfactory and safe product performance. The words "should" or "may" indicate a recommendation or advice that is not essential and not required, but may be useful or helpful.

Please remember that when service is required, your Fleetwood folding trailer dealer knows your vehicle best. Consult him for any assistance you may require.

NOTE: Federal law requires you to register the serial numbers of your trailer tires. For your protection, the original equipment tire serial numbers must be recorded on the warranty registration form received with your trailer. Your dealer will supply you with the necessary forms to register any additional tires (spares) you may purchase. Tire registration is not a guarantee or warranty for either the tires or the trailer.

NOTE: Illustrations in this manual represent function and may or may not be specific in their depiction of actual equipment, interior or exterior decor or design, and options as installed on or in your trailer. This product is designed for recreational use and short-term occupancy only. It is not designed nor intended to be used as permanent housing.

IMPORTANT CONSUMER INFORMATION

REPORTING SAFETY DEFECTS

If you believe that your vehicle has a defect that could cause a crash or could cause injury or death, you should immediately inform the National Highway Traffic Safety Administration (NHTSA) in addition to notifying Fleetwood Folding Trailers, Inc. If NHTSA receives similar complaints, it may open an investigation; and if it finds that a safety defect exists in a group of vehicles, it may order a recall and remedy campaign. However, NHTSA cannot become involved in individual problems between you, your dealer, or Fleetwood Folding Trailers, Inc. To contact NHTSA, you may either call the Auto Safety Hotline toll free at 800/424-9393 (or 366-0123 in Washington, D.C. area) or write to NHTSA, U.S. Department of Transportation, Washington, D.C. 20590. You can also obtain other information about motor vehicle safety from the Hotline.

To report safety defects in the provinces of Canada, those residents should notify Road Safety and Motor Vehicle Regulations, Directorate of Transport Canada, Ottawa, Ontario K1A 0N5 (800/333-0510).

NOTICE TO DEALER AND CONSUMER

Because brake requirements are governed by state or provincial regulation, the requirements vary from state to state. To ensure compliance with applicable regulations, we recommend you check with your Department of Motor Vehicles to determine if brakes are required on your trailer. Available through your dealer is an accessory electric brake package that can be installed on your trailer. Read all corresponding brake manuals associated with the installation of electric brakes or brake controllers.

PRE-TRIP PREPARATIONS

Before you seek out those favorite recreational campsites with your new Fleetwood folding trailer, we suggest you first make these pre-trip preparations. Read the information in this booklet very carefully. Please note that the text for the set-up and take-down instructions does not differentiate between models. When the text does not apply to your model, continue to the next applicable step. Set up and take down the trailer per the instructions several times to familiarize yourself completely with the procedure and to prevent unintentional damage to the equipment.

Establish a tool kit for your trailer's maintenance needs and stow it in the trunk of your tow vehicle. The tool kit should include items such as a standard slot screwdriver, standard Phillips screwdriver, pliers, hydraulic or scissor jack (1 1/2 ton), 13/16" lug wrench, stabilizer jack handle (furnished), crankshaft handle (furnished) and four wheel chocks.

Final preparations should include the proper loading and physical check of the trailer before the trip. The trailer should be loaded with these basic rules in mind:

1. Keep your trailer as light as possible. Reducing cargo weight will increase gas mileage. Distribute the cargo weight as evenly as possible. **Be certain that a minimum of 10% to 15% of the overall trailer weight is on the ball hitch of the tow vehicle. Less than 10% will result in a negative tongue weight which can cause whipping or swaying while towing.**
2. Water tanks do not need filling unless primitive camping is planned; fill water tanks at campground to reduce towing weight.

Make your first trip close to home if possible. This will serve as a preparatory trip to see that everything works and what other items you will need to take.

A physical check should also be made per this checklist. Be certain that:

1. Tires are inflated to the recommended pressure as indicated on the tire sidewall. The three main causes for early tire wear and/or premature tire failure are under inflation, over loading (cargo), and improper towing (see towing section). Due to the relatively small tire sizes used on folding trailers, always check the tire air pressure before each camping trip. Temperature changes can result in loss of tire air pressure. See Specification Chart located inside trailer for cargo capacities.

2. Wheel lug nuts are properly torqued: 12" wheels, 50-75 foot pounds; 13" wheels, 90-120 foot pounds. Check torque before first trip. Re-torque after first 10, 25, and 50 miles. Re-torque periodically thereafter and before each trip.
3. The tongue coupler is securely fastened to the ball hitch with safety pin in place.
4. The safety chains are attached to trailer and tow vehicle hitch (chains must crisscross).
5. The electrical pigtail is connected.
6. All lights on the trailer are functioning properly.
7. The L.P. gas bottle valve is closed and tank is secured to the mounting brackets.
8. The cooler and other cargo items are securely held in place.
9. All doors and latches are securely fastened and locked.

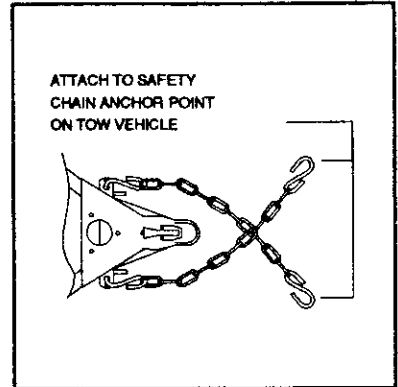

We hope you read and follow these instructions and helpful hints very closely. If you do, you will receive the maximum benefit from your Fleetwood folding trailer.

TOWING AND TRAILER WEIGHTS

TOWING

It's of utmost importance to keep the trailer as level as possible when hooked to the tow vehicle's hitch. Towing a trailer with the tongue inclined will cause premature tire wear. This is also found to be true if the tongue area is angled downward. Even if you've towed before, you'll want to get the feel of maneuvering any new outfit, so practice starts, stops, parking, braking, and turning. When driving around town, always check the traffic clearance before pulling out from the curb or shoulder into the main traffic flow.

IMPORTANT: Towing a trailer attached to a step bumper may interfere with or limit your turning radius. Trailers equipped with front storage compartments or decks have a shorter turning radius. On front deck models, ensure all cargo is secured by using the provided retaining handles. (Cargo straps not provided.)

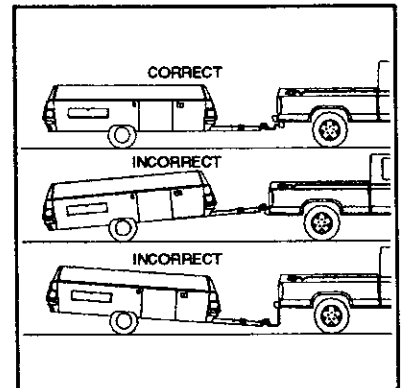

For turns, pull past your turn or intersection sufficiently before turning so as not to run into the curb or obstructions. The longer your trailer, the wider you must swing for clearance. Most new owners are surprised at how well Fleetwood folding trailers track and how little additional maneuvering space is required, but don't let this cause you to forget it's behind you. During parking or backing, remember that the rear of the folding trailer moves opposite to the rear of the towing vehicle. Start by simply placing your hand on the bottom of the steering wheel, then moving your hand left (wheel turning right) will move the trailer to the left and vice versa. On the road, maintain a safe driving distance from other vehicles. A safe driving distance is the total length of your towing vehicle and folding trailer combined for each ten miles per hour of speed. When approaching a downhill grade, downshift, letting the engine compression act as a brake. Should you need added braking, apply your brakes as required. When approaching an uphill grade, the answer is the same - downshift. This keeps the engine from

lugging down which may overheat from laboring in a higher gear. Your towing equipment, its adjustments and how you load the trailer will have a great effect on trailer towing stability and handling. *Be sure to use a tow vehicle that is large enough for your trailer and has the needed power and appropriate towing equipment package.* Hitching up your trailer will become routine with experience. Make it a habit to examine all hitch components before hitching the trailer. Check for cracked or bent parts, cracked welds, and deformed or stripped bolts. Be sure the hitch ball is tight and well lubricated. Inspect the safety chains. If you find defects in any hitch component, correct it before towing the trailer.

IMPORTANT: We recommend weighing your trailer periodically to ensure that the weight limitations of the trailer are not exceeded. To determine specific weights of your Fleetwood folding trailer, follow these procedures using a platform scale such as those used by trucking companies or highway weigh scales:

GROSS VEHICLE WEIGHT: Pull folding trailer on the scale, lower the tongue jack, and disconnect the trailer from tow vehicle. Move tow vehicle off of the scale. Both the trailer axle and tongue jack must be on the scale. The measured weight of the loaded trailer must not exceed the Gross Vehicle Weight Rating (GVWR) of the trailer. Cargo or equipment must be removed until the GVWR is not exceeded.

GROSS AXLE WEIGHT: Position the trailer so that only the axle rests on the scale and the tongue jack is off the scale.

TONGUE WEIGHT: Position the trailer so that only the tongue jack rests on the scale. The tongue weight must be 10% to 15% of the Gross Vehicle Weight for best towing results.

DEFINITIONS OF TRAILER WEIGHTS

DRY OR UNLOADED VEHICLE WEIGHT (UVW) - The weight of the trailer as built at the factory. The UVW does not include cargo, fresh water, L.P. gas, or installed accessories.

GROSS AXLE WEIGHT RATING (GAWR) - Weight carrying capacity of the axle while the trailer is in tow.

GROSS VEHICLE WEIGHT RATING (GVWR) - The maximum permissible weight of this trailer. The GVWR should not exceed the sum of the unloaded vehicle weight plus the net carrying capacity (GVWR equal to or less than UVW + NCC).

GROSS COMBINATION WEIGHT RATING (GCWR) - The value specified by the tow vehicle manufacturer as the maximum allowable loaded weight of the tow vehicle with this towed trailer.

NET CARRYING CAPACITY (NCC) - The weight of all additional goods placed in or on the camping trailer and trailer hitch while in tow.

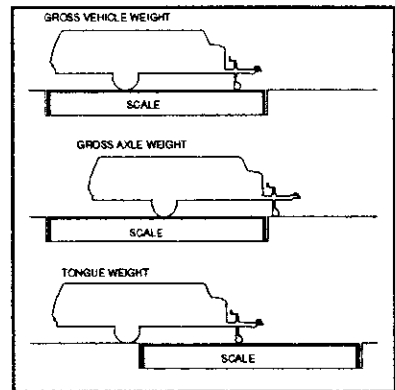

NOTE: Cargo weight will include all accessories and fluid (L.P. gas, water).

WARNING: Do not exceed the rated load of the tow vehicle, the trailer, or the rated load of any axle. Exceeding the GAWR or GVWR of your tow vehicle or trailer can cause undesirable handling characteristics and may create a safety hazard. Check your tow vehicle's owner's manual for additional towing specifications.

Following is a sample Trailer Weight Information Card. The card for your specific model will be in your trailer. Trailer weights listed on the Specification Label (located in the trailer) are subject to 5% variation due to raw material densities.

TRAILER WEIGHT INFORMATION:	CONSULT OWNER'S MANUAL FOR SPECIFIC WEIGHING INSTRUCTIONS AND TOWING GUIDELINES.
MODEL TAOS	GVWR 1,700
UVW 995	NCC 705
WEIGHTS +/- 5%	
THIS TRAILER IS CAPABLE OF CARRYING UP TO	5 GAL.
OF FRESH WATER (INCLUDING WATER HEATER) FOR A TOTAL OF	42 LBS.
<i>REFERENCE: WEIGHT OF FRESH WATER IS 8.345 LBS/GAL.</i>	
GVWR	<i>GROSS VEHICLE WEIGHT RATING MEANS THE MAXIMUM PERMISSIBLE WEIGHT OF THIS TRAILER. THE GVWR IS EQUAL TO OR GREATER THAN THE SUM OF THE UNLOADED VEHICLE WEIGHT PLUS THE NET CARRYING CAPACITY.</i>
UVW	<i>UNLOADED VEHICLE WEIGHT MEANS THE WEIGHT OF THIS TRAILER AS BUILT AT THE FACTORY. IF APPLICABLE, IT INCLUDES FULL GENERATOR FUEL, ENGINE OIL, AND COOLANTS. THE UVW DOES NOT INCLUDE CARGO, FRESH WATER, LP GAS, OR DEALER INSTALLED ACCESSORIES.</i>
NCC	<i>NET CARRYING CAPACITY MEANS THE MAXIMUM WEIGHT OF ALL PERSONAL BELONGINGS, FOOD, FRESH WATER, LP GAS, TOOLS, DEALER INSTALLED ACCESSORIES, ETC., THAT CAN BE CARRIED BY THIS TRAILER. (NCC IS EQUAL TO OR LESS THAN GVWR MINUS UVW).</i>
SAMPLE ONLY	
CD-127	

To calculate the available Net Carrying Capacity (NCC) with full LP gas bottle and a full water tank, these weights must be added to the Dry or Unloaded Vehicle Weight (UVW) first.

EXAMPLE:	L.P. gas in one bottle	20 lbs.
	10 gallons water *	<u>83 lbs.</u>
	Total fluid weight	103 lbs.
	GVWR (Taos)	1700 lbs.
	UVW (includes fluids)	- <u>1098 lbs.</u>
	Available cargo weight for transit	602 lbs.

* Water weighs 8.345 pounds per gallon.

IMPORTANT: Optional accessories added to the trailer must also be added to the Dry or Unloaded Vehicle Weight (UVW) when calculating Net Carrying Capacity (NCC). It is not recommended to install accessories to the rear of the trailer frame. Adverse towing characteristics could occur due to light tongue weight.

APPROXIMATE WEIGHTS OF COMMON ACCESSORIES

The following weights, if installed on your unit, must be added to the unloaded vehicle weight (UVW) and are to be considered as a portion of net cargo capacity (NCC):

<u>Accessory</u>	<u>Weight</u>	<u>Accessory</u>	<u>Weight</u>
Destiny Step	20 lbs.	16,500 BTU Furnace	25 lbs.
8' Screen Room	24 lbs.	Norcold Refrigerator	49 lbs.
10' Screen Room	25 lbs.	Double Crossbar Kit	25 lbs.
12' Screen Room	27 lbs.	Frame Mount Bike Carrier	7 lbs.
8' Canopy	17 lbs.	Air Conditioner (13,500 BTU)	110 lbs.
10' Canopy	20 lbs.	Air Conditioner Kit	16 lbs.
12' Canopy	23 lbs.		

*For additional accessory weights, contact your authorized Fleetwood Folding Trailer dealer.

Due to the overall length and lighter tongue weight on the front storage box and deck models, undesirable towing characteristics may occur until additional weight can be placed inside the front storage box compartment.

NOTE: Cargo weights for front storage box and deck model trailers must not exceed 150 pounds.

CAUTION: With the added trailer weight of optional accessories, weight distribution of the trailer may become unbalanced. This could result in a trailer sway condition while in transit. Certain makes and models of tow vehicles may not be factory equipped to handle these situations. Therefore, a weight distribution hitch or anti-sway device is recommended.

A recommended hitch is the Reese 350 Mini Weight Distributing Kit specifically designed for folding trailer applications. This hitch may or may not be applicable for your particular tow vehicle. Check with your local

dealer for hitch applications.

NOTE: Must be used with a 2" hitch receiver.

Fleetwood Folding Trailers, Inc. reserves the right to change specifications, design, or material of its products at any time without notice or incurring any obligation to incorporate such changes in any product previously manufactured.

SET-UP INSTRUCTIONS

IMPORTANT: Operations for items such as the lifting system, stabilizers and galley may vary between the different series of trailers. The operating instructions for all series of trailers are outlined in this manual. When reading this manual, follow the operating instructions that pertain to the specific equipment on your particular model trailer.

Select a level campsite, preferably not on soft or sandy terrain. Pull or back the folding trailer to desired position for campsite. Place wheel chocks in front and in back of both wheels. Disconnect electrical pigtail and safety chains, and release the coupler release handle. Pull the lock pin (located on the tongue jack) and let the tongue jack swing down into position. Allow the lock pin to lock the tongue jack in place in the top left hole in the brackets.

WARNING: Failure to engage the tongue jack lock pin could result in the trailer tongue falling resulting in injury to yourself or others. Never push or pull the trailer with the tongue jack fully extended.

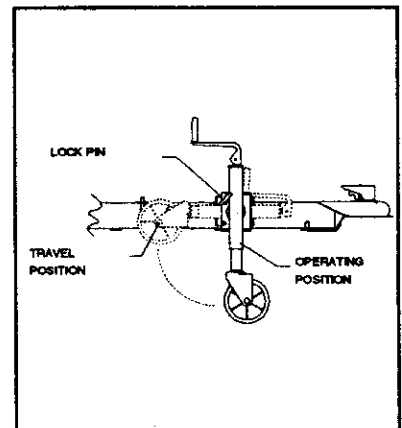

Tongue Jack

Pull the handle of the tongue jack up and rotate the handle in a clockwise motion to lift the trailer tongue up and off the ball hitch. Never attempt to physically lift the trailer tongue up and off of the ball hitch. To prevent interference during the set up of the trailer, drive the vehicle away from the trailer. Adjust the tongue jack height so that the trailer is level horizontally. Unlatch the four "top" latches. Insert the key into the access door lock and turn clockwise. The push-button and handle will pop out. Rotate the handle clockwise to open the access door. Pull outward on the access door to provide an entrance. (Some models may require the top assembly to be slightly raised before the access door can be lowered.)

IMPORTANT: Before lowering the stepper access door, ensure that the area directly beneath the access door is free from obstacles to prevent damage to the exterior finish of the access door. Do not store any perishable items inside the stepper access door with the storage compartment feature, located at the bottom of the door. This is not a water tight compartment.

The hinged access door can be opened and latched into the open position utilizing the retaining latch on the body panel.

NOTE: Either style of access door can be closed and locked with the screen door assembly installed.

OPERATING LIFT SYSTEM

CAUTION: Ensure all top latches are unhooked prior to raising the top assembly.

CRANK-UP/CRANK-DOWN LIFT SYSTEM

Attach crank handle onto the crank shaft. The crank shaft can be located on the rear body panel or down at the rear bumper. Rotate the crank handle in a clockwise motion to raise the top until it is fully extended or the tent fabric becomes reasonably taut, whichever comes first. A clicking sound should always be audible while cranking the top up. If not, when the top is fully raised, lightly over-crank the handle to engage the clutch mechanism.

NOTE: Crank handles are usually stored inside the step door, cabinet, or front storage box on most models.

WARNING: Failure to ensure the crank-up/crank-down lift system is properly operating could result in an unexpected descent of the top assembly or rapid counterclockwise rotation of the crank handle. Do not release the crank handle if the audible clicking sound is not heard. Lower top assembly completely and repeat set-up instructions.

STABILIZER JACKS

CRANK-DOWN STABILIZERS

From underneath the corner of the trailer, insert crank handle onto stabilizer shaft and rotate crank handle clockwise to extend jack to downward position. Repeat for remaining stabilizers and return crank handle to storage location.

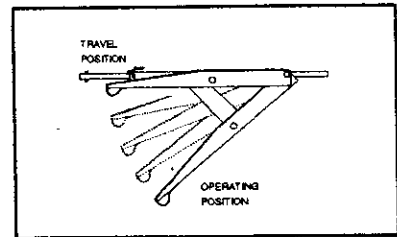

Crank-Down Stabilizer

IMPORTANT: The threaded shaft of the crank-down stabilizer jacks should be lubricated (with white lithium grease or equivalent) at the beginning and end of each camping season to deter corrosion due to weather related elements.

SWING-DOWN STABILIZERS

To release the stabilizer jacks from the locked travel position, reach under the corner of the trailer, firmly grasp the jack and push it toward the center of the trailer (approximately 1/2") and swing down to lock the jack in the lowered position. By pushing down on the quick release lever, the inner leg can be extended to the ground.

Insert the stabilizer handle through the front hole and allow handle to pass completely through the rear hole of the stabilizer. Apply downward pressure to extend the inner legs of the stabilizer jacks to stabilize the trailer. Over-stabilizing the trailer can result in difficult operation of the access door or screen door when completely set-up.

IMPORTANT: Ensure stabilizer handle is extended through the rear hole of the stabilizer or inadvertent damage can occur to the inner stabilizer leg (holes).

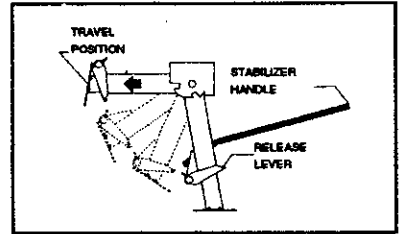

Swing-Down Stabilizer

Repeat procedure for remaining stabilizers.

NOTE: Not all model trailers are equipped with 4 stabilizers. Certain models utilize the trailer tongue jack as a stabilizing support.

CAUTION: Do not lower the stabilizer jacks prior to raising the trailer top as this can place an undue stress on the trailer frame and lift system resulting in premature wear. Do not use the stabilizer jacks to take the weight of the trailer off of the tires. The jacks are intended **ONLY TO "STABILIZE."**

WARNING: Do not lie under trailer when putting stabilizers down or up. Should the trailer fall, serious bodily injury could result.

IMPORTANT: Lubrication of the swing-down stabilizer jacks is not recommended, due to the metal surface contact needed for proper operation of the inner stabilizer leg.

Because of certain terrain conditions, it may be advisable to locate flat blocks of wood or flat rocks under the base plates of the stabilizer jacks.

CAUTION: DO NOT utilize trailer in the open position without having the stabilizers fully extended.

BEDS

Place hands on the bed frame and pull outward until the bed stops.

IMPORTANT: This movement must be done slowly and evenly to prevent inadvertent jamming or wedging of the bed on the sliding tracks.

NOTE: Periodically, place one drop of lubricant (example: 3 in 1 oil) between the plastic bed roller and mounting bolt. This will ensure smooth operation of the beds.

IMPORTANT: DO NOT place any weight on the beds while they are extended without first attaching the lower bed supports to the frame. Damage to the bed rails or bed frames may result. Any damage to the bed rails or bed frames, resulting from weight being applied to the bed area without the lower bed supports in position, will not be considered a warranty item.

Kneel down beneath the side of the fully extended bed. Pull down and swivel the lower bed supports from their travel positions. Lift the bed slightly while placing the free end of the bed supports over the support pegs located on the trailer frame or rear bumper. Perform same procedure for the opposite bed. For expanda-bed information, see "Expanda-Bed" section.

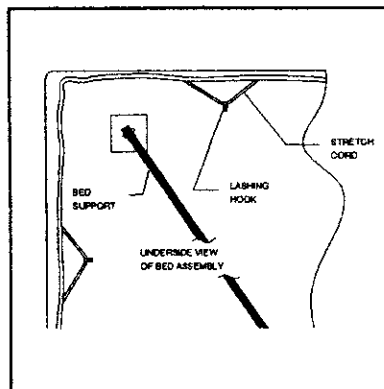

Tent Bed Hooks

IMPORTANT: Ensure lower bed support is fully engaged on the peg, otherwise any weight placed on the bed will cause damage to the bed rail or bed frame. Lower bed supports are designed to swivel into travel or setup position; do not force the bed supports when setting up or taking down.

GLIDE-OUT COMPARTMENT (where applicable)

Locate the two locking handles on the outside edge of the glide-out compartment. Pull the handle straight out and rotate 90° to disengage the lock arms from the main body of the trailer. With the lock arms disengaged, place your hands inside the two inner "grab" handles. Firmly and evenly extend the glide-out compartment from the trailer. Pull outward until the glide-out engages the detent or lock position. Slightly lift upward while pulling out. A gentle rolling motion can be felt as the rollers lock into the track. To ensure the glide-out is "locked-in", gently try to push the glide-out compartment inward. If moderate resistance is felt, the glide-out is correctly extended.

IMPORTANT: Ensure the tent enclosure (bay window) does not catch against the body rails while extending the glide-out. Failure to do so will cause the tent enclosure to tear or snag. Maximum weight rating of glide-out compartment is 1000 pounds.

WARNING: Failure to ensure the glide-out compartment is "locked-in" could result in an unexpected closing of the glide-out. Ensure the surrounding area is clear of all obstacles. Personal injury or damage to the trailer could occur.

TENT ENCLOSURE

From outside the trailer: With both beds fully extended and supported, grasp the bottom edge of either the front or rear tent enclosure and gently pull until the tent fabric is pulled out toward the end of the beds. Standing at either side of the bed, reach in underneath the tent fabric and grasp the side of the canvas bow and rotate toward

the end of the bed. Pull the tent at the bottom over the bed edge and attach the exposed stretch cords to the nearest hooks on the underside of the bed. There are six to eight hooks around the underside perimeter of each bed assembly depending on the model. Repeat for opposite bed end. (Refer to diagram on tent bed hooks and expanda-bed set-up.)

GLIDE-OUT MODELS (where applicable)

Attach Velcro around perimeter of bay window to glide-out compartment and side body rails.

SWING-LEVEL GALLEY

From inside the trailer: Grasp the tubular bar of the swing-level galley (at the decal) and raise until the bottom of the upper galley rests securely on the top of the lower galley.

BAY WINDOW (where applicable)

TIP-OUT MODELS

Push tenting and window cover outward away from galley cabinet. Lift swing-level galley into position. Locate the bay window adjustable U-shaped support bow assembly. Place U-shaped support bow into bay window and insert each leg tip into the recessed cups at each end of the lower galley. Adjust bow spring clips as necessary for tautness.

Locate upper removable bay window support rod. Insert tip into top hole in metal U-shaped support bow. Attach opposite end of support rod to metal retainer bracket located on the top assembly and adjust the spring clip for proper tension.

A 12 volt auxiliary plug-in jack is located above the tip-out galley on the top assembly. The 12 volt jack is for connection of an auxiliary overhead light (not supplied).

HINGED GALLEY/STOVE CABINET

HINGED UPPER GALLEY

Grasp the towel rack (metal bar at rear of galley) of the hinged upper galley assembly. Lift up and rotate toward the outside of the trailer.

NOTE Both the swing level and hinged galleys must engage the "kill switch" atop the lower cabinet top to activate the 12 volt circuit for the top lights and internal appliances.

HINGED STOVE CABINET

Unsnap the nylon web travel strap from the bottom of the stove. Grasp the stove cabinet and rotate toward the rear of the trailer. Ensure the cabinet is seated properly on the lower cabinet assembly. Locate flexible gas line and route into the lower cabinet. Route flexible gas line through hole in interior wall paneling and connect to brass gas quick disconnect on outside frame of trailer.

CAUTION: Ensure that the drapery panel behind the galley is secured with a safety tie or Velcro tab to eliminate the possibility of the drapes coming in contact with the stove.

STORAGE SHELF (where applicable)

Storage Shelf: Raise the storage shelf and slide to rear of the cabinet top. Lower the two side supports and insert into the slotted groove of the cabinet top.

GLIDE-OUT MODELS (where applicable)

Ensure the glide-out compartment is fully extended and "locked-in". Rotate the attached bed bow support upward to the vertical position. Insert the tip of the removable tent support rod into the top hole in the bed bow. Attach the opposite end of the tent support rod to the metal retainer bracket located on the top assembly directly above the glide-out compartment. Adjust the support rod spring clip as needed for proper tension.

A 12 volt auxiliary plug-in jack is located above the glide-out dinette on the top assembly. The 12 volt jack is for connection of an auxiliary overhead light (not supplied).

EXPANDA-BED (where applicable)

Ensure cushion assembly is attached to the Velcro strips on top of the expanda-bed support. Grasp the nylon handle strap and rotate the expanda-bed outward. Lower the expanda-bed until firmly resting on the support angle attached to the main bed assembly. Tuck nylon handle strap under expanda-bed cushion. Attach exposed stretch cord to underside of bed.

WARNING: Test expanda-bed to ensure the bed is completely lowered onto the support angle attached to main bed. Ensure all privacy curtains are free and clear when rotating the expanda-bed outward and inward. Ensure stretch cords are attached to hooks on underside of bed. Failure to do so may cause personal injury or damage to property.

BED BOW SUPPORT

To completely support the tent enclosure over the beds (front and rear), attach the removable bed bow supports by inserting the pole tip into the upper bed bow hole. Insert the opposite end of the bed bow support into the metal roof retainer. These supports can be adjusted by pressing the spring clip on the pole and extending the rod to the next adjustable hole. The bed bow supports may be stored under each mattress assembly.

DINETTE

Where applicable: Lift the backrest off the dinette table. Lift the table and place face-down on bed mattress for later set-up. Slide the seat cushion inboard. Set the backrest in place.

NOTE: Glide-out compartment seat benches will have hinged metal backrest supports which must be raised prior

to setting the backrests in place.

Slide the seat cushion in place against the backrest, making sure that the plastic stops on the bottom of the cushion are wedged firmly against the interior frame of the seat bench. Where applicable, the color band of fabric on the backrest will be oriented at the top of the seat cushion once installed. Throw pillows are to be installed in the corner of the wrap-around goucho dinette.

NOTE: To lift dinette seat cushion, be certain to push the seat cushion firmly toward the backrest before lifting in order to prevent inadvertent damage to the plastic stops.

Extend the table legs completely so that both leg supports lock into position. Set table upright and check to ensure it is stable.

For Bed Application: Lower table to storage or travel position (ensure table is oriented correctly onto bench supports). Place backrest cushions atop table and seat cushions over benches.

IMPORTANT: The table top could be damaged by exposure to rain, excessive moisture or extended periods of sunlight.

SCREEN DOOR

Unfasten the two screen door nylon web retaining straps. This will allow the screen door to hang by its glide cables. Standing at the door opening, pull down on the spring pin clip retaining the door frame and swivel clear of the engagement hole. Standing at the door threshold, reach up and grasp the bottom of the screen door with both hands. Raise and push the door toward the far side of the trailer to release it from its retaining bracket. Hold screen door up from the floor and move it toward the door opening.

From outside the trailer, grasp the door frame with both hands, one on either side, lower screen door into door threshold at base of doorway. Unlock screen door latch (handle) and step inside. Holding the door against the top assembly, lock into place with the two screen door sash locks or lock tabs. Fasten the tent material on either side of the door onto the mating Velcro on the door frame. Attach all tent material patches to mating Velcro on outside of door frame and body rails.

The top window pane of the screen door can be adjusted to various heights for ventilation.

PULL-OUT GOUCHO BED (where applicable)

For bed application: Remove the backrest cushions from goucho and set aside. Standing at the center of the goucho, grasp the seat frame and gently pull outward toward the center of the trailer until the goucho is fully extended. Lay the backrest cushions on top of the exposed goucho frame. Always ensure that the plastic goucho guides (on underside of seat

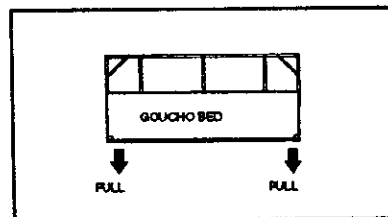
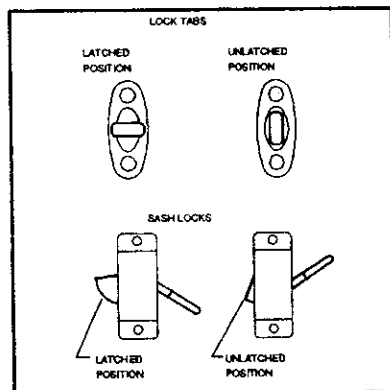

Goucho Bed

cushion) are securely positioned within the routed bench slots. Failure to do so could cause the goucho bed to unexpectedly disengage.

For seat application: Slide goucho bed inward and install backrest cushion above seat cushion against wall.

FRONT TRUNK STORAGE AREA

To access the trunk area, in trailers so equipped, with the trailer in the **closed position**; unlock the trunk lid top latches. Lift the trunk storage lid. Remove prop rod from the retaining brackets located along the front rail. Insert the free end of prop rod into the retainer on the trunk lid to hold in the open position. **Side access** to the trunk area can be achieved by opening the side access door on the curbside of the trailer. Insert the key and turn clockwise to open. The front trunk storage area can be accessed from inside the trailer with the trailer in the **open position** through the front interior paneling. Slide the interior access door panel to the right to gain access.

NOTE: Ensure sliding access panel is closed prior to returning the trailer to the travel position.

IMPORTANT: Front trunk cargo weight capacity is 150 pounds.

FRONT TRUNK LIGHTING

For models equipped with front trunk storage, interior lighting is provided to allow visibility in low lighting situations such as evening arrival at campgrounds.

With the trailer in **closed** position and the tow vehicle **connected** to the trailer:

1. The tow vehicle exterior marker or running lights **must** be turned on to supply 12 VDC to the interior trunk light.
2. Lifting the trunk lid will automatically turn on the interior trunk light.

With the trailer in the **open** position and the tow vehicle **disconnected** from the trailer:

1. 12 VDC power must be supplied by either having the converter plugged into 110 VAC supply or by an auxiliary battery. Converters will switch-over automatically from 12 VDC to 110 VAC power supply.
2. Locate the rocker switch on the front lower galley section near the storage sliding access panel. Turn switch to the "on" position to activate interior storage light.

SHOWER

SHOWER CURTAIN

Install the shower curtain hooks to the shower curtain rod and attach the curtain. Secure the shower curtain rod to the top assembly with the nylon retaining straps.

INSIDE SHOWER OPERATION

Connect a garden hose (not supplied) to the tub drain located on the lower portion of the exterior body panel and

route to a park-supplied drainage receptacle or a suitable waste container. The cassette potti/shower unit is equipped with a fold-down counter top lid. Lift the lid vertically and secure in place by inserting the nylon strapping through the metal retaining loop on the top assembly. Attach the two mating Velcro halves together. Connect the shower head hose to the tub faucet fitting and hand tighten. Attach shower head to retaining bracket. Adjust the shower curtain to ensure that the total area around the tub is sealed and the curtain bottom is inside the tub. Open hot and cold faucets 1/4 turn and adjust to comfortable temperature and pressure desired. If using the built-in water tank, ensure the 12 VDC electric water pump is turned on to supply adequate pressure.

NOTE: When your trailer is being stored for extended periods of time, it is recommended that the shower curtains be removed from the unit, folded, and stored indoors under fairly constant temperatures. Extremes of temperatures could have an adverse effect on the plastic material.

OUTSIDE SHOWER OPERATION (where applicable)

Open the shower access door, located on the side body panel, and swing shower head out away from the panel. Slowly open faucet control knobs. Turn the control lever on top of the shower head to allow water to flow. Lift the shower head off of the retaining bracket to allow the shower to be utilized away from the trailer. Gently pull the shower head and hose to desired length.

NOTE: Either city water supply or the electric pump system must be in operation to allow water to flow to the outside shower.

WARNING: The hot water drawn at the shower is directly out of the water heater. The temperature of the water could be as high as 150°. Scalding could occur if the hot water is not diluted. DO NOT expose the body directly to the undiluted hot water.

INSIDE GALLEY STOVE USE

Unfasten the catch securing the stove cover. Raise the stove cover into position. Rotate the splash guard and secure to the side of the cook top. Check to ensure all burners on the stove unit are turned off. Open the valve on the LP gas bottle all the way by rotating handle in counterclockwise direction. Where applicable, turn gas shut-off lever, located on the quick disconnect, to the "ON" position. Light a match and hold near the LP burner. Slowly open one LP burner until flame ignites. Do not turn the LP burner on high as an unusually high flame may occur when lit. If the match blows out, turn the LP burner off and repeat lighting sequence.

NOTE: Initially, it will take 20-40 seconds for the gas to flow from the bottle to the burner after which the LP burner will ignite.

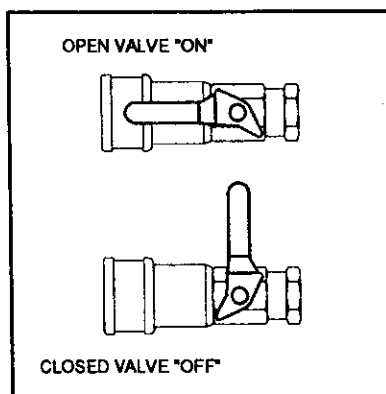

Gas Quick Disconnect

IMPORTANT: Do not place hot cooking utensils on cabinet tops or table top. Damage to surface could occur. Do not use stove unless the drapes are secured to the galley back or

plastic drape track behind the upper galley assembly.

WARNING: On certain model trailers, the inside stove is removable for outside use. Always ensure the stove retaining latch (located on the upper galley front) is in the "locked" position when using the stove for inside use.

When the trailer has been over rough terrain, the gas piping and appliances should be checked by an authorized L.P. gas supplier for leaks. **DO NOT** attempt to test with a lighted match. **DO NOT** tamper with the gas bottle regulator; it is factory adjusted. Failure to adhere to this warning could lead to an undetected gas leak resulting in fire and/or explosion.

Authorized L.P. gas suppliers should not check copper and brass plumbing lines and fittings for leaks using ammoniated or chlorinated household type detergents. These can cause cracks to form on the line and brass fittings.

"COOLER LATCH" STYLE

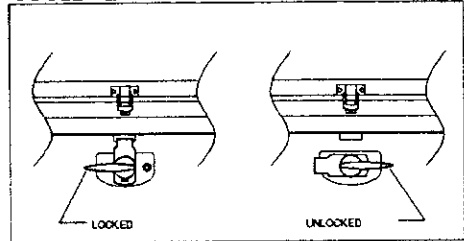

"TWIST LATCH" STYLE

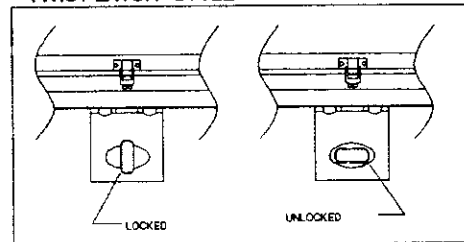

Retaining Latch

OUTSIDE STOVE USE

HIGH PRESSURE OUTSIDE STOVE

Remove auxiliary stove from storage location. Swing support leg into position away from the stove bottom. Using both hands place stove retaining bar onto mounting bracket located on the curbside body panel and lower stove unit until support leg rests against body panel. Ensure outside stove is fully engaged onto the mounting bracket.

IMPORTANT: The outside stove counter top could be damaged by exposure to rain, excessive moisture, or extended periods of sunlight.

Attach gas line from stove to connection located at the bottom flange of curbside rear panel. All gas connections should be tight.

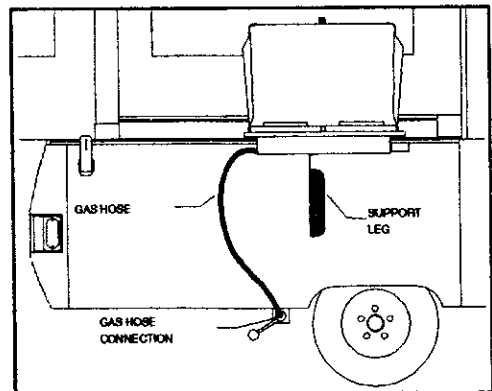

High Pressure Outside Stove

WARNING: This stove connection should NOT be attached directly to any other unregulated L.P. gas source.

Open stove cover and secure the splash guards. The outside stove is now ready for use.

WARNING: Maximum weight to be placed on the cook top of the stove should not exceed 25 pounds. Failure to comply could result in damage to the stove or injury. Keep all flammable objects from open flame or hot burner surface.

WARNING: If a gas leak is suspected, contact an authorized L.P. gas supplier for assistance. Never attempt to check gas systems by yourself as fire or explosion may occur.

Follow instructions in reverse order to store stove.

LOW PRESSURE INSIDE/OUTSIDE STOVE

The following steps should be followed to remove the stove from the inside location in order to utilize the outside location.

Disconnect the gas supply line by first turning the gas shut-off valve to the "OFF" position. (Refer to gas quick disconnect diagram.) For Canadian trailers only: A secondary gas shut-off valve, located by the gas bottle regulator, must also be turned "OFF" before removing the inside stove.

WARNING: Care should be used when disconnecting gas. Never disconnect the stove valve while smoking or with open flame nearby. A small amount of excess gas will be released from the stove module at the time of disconnection.

Unlatch the stove retaining latch (located on front of galley cabinet). Lift and remove the stove from the upper galley cabinet. Carry the stove module outside the trailer. Holding the stove module with both hands, engage the stove hanger onto the retaining bracket located on the curbside (door side) of trailer. Position the stove support rod onto the two retaining loops located on the bottom front of the stove module. Tilt the stove slightly upward and engage the bottom portion of the support rod onto the lower retaining bracket located on the lower section of access door or on the lower frame channel depending on the model. Engage the stove gas line onto the gas quick disconnect located at the bottom flange of curbside panel.

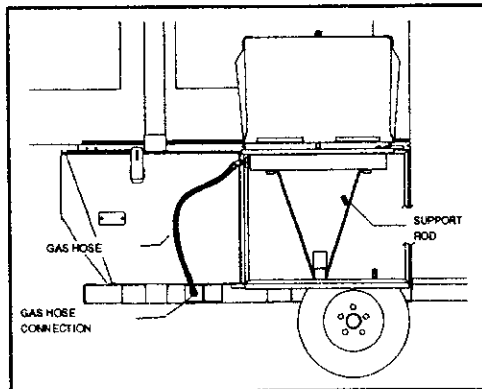

Low Pressure
Inside/Outside Stove

NOTE: The outside quick disconnect does not utilize a shut-off lever.

IMPORTANT: The inside/outside stove counter top could be damaged by exposure to rain, excessive moisture, or extended periods of sunlight.

For inside use: Open the stove cover and secure the splash guards on both sides of the stove cook top. Ensure the drape tabs are secured to the galley back or drape track if using inside. The stove is now ready for use.

WARNING: Maximum weight to be placed on the cooktop of the stove should not exceed 25 pounds. Failure to comply could result in damage to the stove or bodily injury. Keep all flammable objects away from open flame or hot burner surface.

Follow instructions in reverse order to move stove module back to the inside galley position.

NOTE: In order to obtain full counter space when the stove is being used in the outside position, an optional cutting board can be obtained from your dealer and placed into the counter top cut-out.

Plug 30 amp power cord into park supplied receptacle.

Connect garden hose from city water inlet to park supplied water outlet. (See water system for additional details.)

REMINDER: Upper galley must be positioned atop the lower galley cabinet to depress the "kill" switch to activate 12 volt light system.

TAKE-DOWN INSTRUCTIONS

Unplug the power cord and store. Disconnect the city water hook-up and attach the protective cap onto the external city water connector. Close the gas valve on the L.P. gas bottle.

WARNING: Do not attempt to operate any propane appliance while the trailer is in tow.

From inside the trailer, open and light one L.P. burner and allow to burn until flame extinguishes. This will safely and effectively bleed the system. Turn L.P. burners to off. Allow stove burners to cool. Lower the stove cover and secure for travel.

NOTE: On models equipped as such, ensure removable inside/outside stove is locked into the upper galley or storage position. Never store stove assembly when hot.

Drain all water in the sink and tighten basket strainer. Disconnect the waste system hose from the external trailer connection and replace drain cap.

Close all drapes completely and remove safety ties/Velcro tabs from behind the galley. Detach both front and rear bed bow supports from the metal roof retainer and from the bed bow and stow under each mattress. Detach glide-out compartment and tip-out galley tent supports from roof or bay window (where applicable) and store under front mattress or dinette seat bench.

Lift the dinette table up on end. Apply inward pressure to the leg support locks and retract and secure legs with the strap over both dinette legs. Secure the dinette table by locating it on the rests between the bench seats. Store seat cushions on seat bench frame and backrest cushions face-down on the table. On glide-out models, two cushions store under the collapsed dinette table and two in front of the glide-out goucho.

Lower shower curtain and return cassette/shower counter top lid to the travel position (over top of the shower cabinet).

Swing or flip-over hinged upper galley assembly to travel position on floor. Ensure stove cover and stove assembly (where applicable) are secure. Return the wardrobe cabinet, storage shelves, or expanda-bed to the travel position.

NOTE: On flip-over galleys a small amount of water may be expelled from the P-trap when the galley is turned over.

Beginning at the top of the screen door frame, carefully unfasten the Velcro on either side of the door frame and unfasten tent Velcro patches from outer door frame and body rails.

NOTE: Ensure all removable and sliding window panes have been returned to their original closed position prior to storing screen door.

Step inside the trailer and release the screen door retainers. Step outside the trailer and lock the screen door latch. Lift up and remove the door from the threshold and move door inward. From outside the trailer, grasp the bottom of the door frame, lift up and push the top of the door toward the far side of the trailer. Place the bottom of the door onto the pins on the retaining bracket and lock spring-loaded pin clip into base of door frame and snap web retaining straps. Be certain door is securely engaged on retaining bracket.

Ensure Velcro patches sewn onto tenting at doorway opening are clear of the bed slides when closing the beds.

NOTE: On glide-out models, the glide-out compartment must be closed and secured prior to closing the beds.

Where applicable: From outside the trailer, attach glide-out body rail flap to the three individual pieces of Velcro located along the top side of the body rail. Remove Velcro on tenting from Velcro strips on side of glide-out and Velcro patches from body rails. Ensure glide-out bay window tent support bow is lowered onto the dinette seat bench by reaching under tenting and grasping bow. While holding end of tenting, push bow towards center of trailer until bow lays onto seat bench compartment. Be careful not to pinch fingers under bow. (It may be necessary to disengage tenting from around the bow.) Ensure tent fabric is clear of metal body rails. Lightly lift up on the two inner "grab" handles and push the glide-out compartment against the main body panel. (Ensure lock arms are retracted.) Locate the two locking handles on the outside edge of the glide-out compartment. Rotate the lock handles 90° to engage the lock arms. Push in on the lock handles to secure glide-out and lock the handles against the outside of the glide-out compartment. **Do not attempt to close the glide-out compartment from inside the trailer.** Carefully pull all glide-out tenting to outside the trailer. Where applicable, ensure tip-out tenting hangs to outside of trailer.

Beginning with bed most distant from access door: From outside the trailer, release the stretch cords from the hooks located under the extended bed. Detach tenting from Velcro pads at the end of the body rails. Pull the reinforced flaps at the ends of the stretch cords out from under the bed rails. **DO NOT LAY REINFORCED FLAP ON MATTRESS.** Pull the tent up and over the bed edge at corners. From the center of bed, push in bed tenting as far as possible. From both corners of bed, fold reinforced corners of tenting back against the side canvas.

NOTE: If bed bow does not fall onto mattress, reach under tenting and grasp bow. While holding tenting at end of bow, push bow toward center of trailer until it lays flat on mattress.

Pull tenting away from bed bows and ensure that the tent material is clear of bed slides to prevent pinching of tenting. Raise the bed slightly and remove the lower bed supports from the support pegs on the frame or bumper. Swivel each bed support up and lock into the travel position under the bed. (The bed does not need to be raised to lock in supports.)

From the center of the bed, return bed to travel or closed position by placing hands on the bed frame and gently pushing inward until the bed lightly hits the stops. **If resistance is encountered before bed hits the stop, recheck bed rail area to ensure clearance. Do not force!** From inside the trailer, distribute tenting evenly on mattress to lay as flat as possible. Move to opposite bed and repeat above procedure. Ensure either bed did not push out during this step.

Tuck glide-out tenting into trailer to lay flat as possible on beds; fold sides back against glide-out tenting. Attach glide-out rail flap to Velcro on rail. Tuck tip-out tenting into trailer.

Lower the top to within two feet of the trailer body. Turn crank handle clockwise until a click is heard to prevent the top from closing further.

On all models, lean inside trailer at access door and pull both bed tents by top vinyl toward center. From front to rear of trailer, use "chopping" motion to push in side tenting towards center of trailer. Move along side of

trailer while continuing "chopping" to tuck complete tenting. Lower top to within one foot of trailer body. Turn crank handle clockwise until click is heard to prevent top from closing further. Repeat previous "chopping" motion to tuck any remaining exposed tenting. Lower top to trailer body. No tenting should be exposed.

IMPORTANT: If the top will not seat properly onto the trailer, raise the top and repeat procedure. **DO NOT FORCE!**

Walk around trailer to ensure no tenting is exposed, then close and lock the access door and latch the four top latches.

WARNING: Never pull out or push in beds without the top being fully raised and the glide-out compartment closed.

Set up the trailer tongue jack if it was previously retracted to the towing position.

CAUTION: Be sure the tongue jack is supporting the trailer tongue and is locked in position to prevent sudden collapse of trailer tongue.

IMPORTANT: Do not lower top unless the stabilizers are released.

CRANK-DOWN STABILIZERS

Raise stabilizers to travel position by rotating crank handle counterclockwise. Once the stabilizer is completely raised, over-crank 1/4 of a turn to lock the stabilizer in the raised position. Failure to lock the stabilizer in the raised position could result in accidental descent of the stabilizer while traveling.

SWING-DOWN STABILIZERS

To raise the swing-down stabilizers, press on the quick release lever with the jack handle. Slide inner leg completely up and raise stabilizer to travel position. Ensure stabilizer is in the locked or travel position.

WARNING: Stand clear of the trailer when pressing on the quick-release lever for the trailer will drop when it is released. Do not lie under the trailer when releasing or lowering the stabilizers. Bodily injury could result due to the quick drop of the trailer if these warnings are not followed.

CRANK-UP/CRANK-DOWN LIFT

Rotate the crank handle in a counterclockwise motion and lower the top to within two feet of trailer body.

On all models, lean inside the trailer at the access door and pull both bed sections toward the center to lay flat on the mattresses. Starting outside from the front or rear of the trailer, use a "chopping" motion to push the tenting

in towards center of trailer. Move along the outside of the trailer, while continuing "chopping" to completely tuck the entire tenting. Lower top to within one foot of trailer body and repeat above step. Lower top to trailer body.

IMPORTANT: If the top will not seat properly onto the trailer, DO NOT force it. Raise the top to approximately one foot and recheck tent distribution.

NOTE: Pushing down on the center of the top assembly front and rear before attaching the top latches will ease the closing procedure.

Close and lock the access door. Where applicable, ensure front trunk storage lid, glide-out compartment, and side access doors to the trunk area are locked and secured. Inspect perimeter of top to ensure no tenting is exposed. Lower the top assembly completely and then latch the four top latches.

WARNING: Never extend beds without top being fully raised.

Adjust the tongue jack so that the trailer tongue is higher than the vehicle hitch ball. Back the vehicle close to the trailer and set brake. Using the tongue jack, lower the trailer tongue onto the ball hitch of the vehicle. Engage the coupler release handle by pressing down into the locked position. The coupler has a hole in it for a safety clip or padlock to be inserted for trailer theft protection. Install safety pin and clip or pad lock. Retract the tongue jack wheel fully by turning the handle counterclockwise until it stops, pull the release pin and swing the tongue jack up to the travel position. Bring the tongue jack handle up and over the tongue jack to store.

Attach the safety chains to the tow vehicle receiver so they "criss-cross" under the ball. Remove and store wheel chocks. Connect the electrical pigtail to the mating plug on the tow vehicle. Check to see that all lights on the trailer are functioning properly.

Where applicable: Attach safety cable for electric brake system.

GAS SYSTEM

Liquid propane gas is used in your trailer for three basic reasons: it is inexpensive, portable, and burns with intense heat. This system has been checked at our factory and by your dealer to ensure its safety. Except for the simplest maintenance, this system should be checked by an authorized L.P. gas supplier should any problems develop. The L.P. gas system should be checked each time a gas bottle is changed, every 30 days, after traveling over rough terrain, and prior to using after periods of storage. Due to the importance of this system and the safety precautions built into it, we feel it best to take a little time to describe it to you.

COOKING APPLIANCES NEED FRESH AIR FOR SAFE OPERATION. BEFORE OPERATION, OPEN A WINDOW. This warning label has been located in the cooking area to remind you to provide an adequate supply of fresh air for combustion. Unlike homes, the amount of oxygen supply is limited due to the size of the recreational vehicle, and proper ventilation when using the cooking appliance(s) will avoid dangers of asphyxiation. It is especially important that cooking appliances not be used for comfort heating as the danger of asphyxiation is greater when the appliance is used for long periods of time.

A warning label has been located near the L.P. gas container. This label reads: **DO NOT FILL CONTAINER(S) TO MORE THAN 80 PERCENT OF CAPACITY.** Overfilling the L.P. gas container can result in uncontrolled gas flow that can cause fire or explosion. A properly filled container will contain approximately 80 percent of its volume as liquid L.P. gas.

WARNING: L.P. gas containers, gasoline, or other flammable liquids shall not be placed or stored inside the trailer; accidental fire or explosion may result. L.P. gas containers are equipped with safety devices which relieve excessive pressure by discharging gas to the atmosphere.

IT IS NOT SAFE TO USE COOKING APPLIANCES FOR COMFORT HEATING. PORTABLE FUEL BURNING EQUIPMENT INCLUDING CAMPING STOVES USED INSIDE THE TRAILER MAY CAUSE A FIRE OR ASPHYXIATION.

GAS BOTTLE

The L.P. gas is stored under pressure in the gas bottle located on the tongue of your trailer. This bottle should be kept free of rust at all times. If rust should develop on the bottle, the area should be cleaned completely of the rust, primed, and repainted white. Quite naturally, the service valve on top of the tank should always be closed when the tank is not in operational use, and especially when in transit. Position L.P. tank with safety valve pointing away from trailer.

WARNING: Do not smoke while changing the L.P. gas bottle and extinguish all surrounding open flames to avoid the possibility of fire and/or explosion.

To change an L.P. gas bottle: Turn off the L.P. gas at all burners. Close the valve on the L.P. gas bottle by turning it in a clockwise direction. Disconnect the regulator to the L.P. gas bottle, using a suitable wrench. Canadian or CSA configurations use a flexible rubber hose from the gas bottle to a permanently mounted regulator on the gas bottle support angle. (Regulator threads are left-hand threads. Turn counterclockwise to tighten/clockwise to loosen.)

Loosen the wing nuts from the J-bolts and remove the empty gas bottle. Carefully place the full L.P. gas bottle on the tongue support and secure with the J-bolts and wing nuts previously loosened. Using a suitable wrench, attach the regulator (with the vent facing down) or flexible rubber gas hose to the L.P. gas bottle. Open the valve by turning it in a counterclockwise direction slowly. For Canadian or CSA trailers only, a secondary gas shut-off valve is located next to the permanently mounted regulator. This valve must also be turned "OFF" when using the interior stove assembly for outside cooking. *We suggest that all gas system fittings in the trailer be checked for leaks by an authorized L.P. gas supplier each time a gas bottle has been changed, every 30 days, or after the trailer has tracked over rough terrain.* If a leak is suspected, contact your Fleetwood folding trailer dealer or L.P. gas supplier for assistance.

WARNING: Specific regulator configurations contain both high and low pressure gas systems. The flexible rubber gas hoses for these systems are identified with a label which reads "outside stove" or "inside stove". These gas hoses should be connected or disconnected by a certified gas technician. Improper connections could result in an unexpected explosion or abnormally high flame.

CAUTION: Authorized L.P. gas suppliers should not check copper and brass plumbing fittings for leaks using ammoniated or chlorinated household type detergents. These can cause cracks to form on the line and brass fittings.

Additional fittings are required to the gas system as appliances are added i.e., water heater, furnace, refrigerator. Therefore, any time the gas system is altered, the complete gas system should be rechecked for leaks. If a leak is suspected in the trailer, or the L.P. gas leak detector sounds, a distinctive odor (rotten eggs) will be noticeable. Should this be encountered, follow these directions:

1. Open the door and exit the unit, leaving the door open.
2. Close the valve on the L.P. gas bottle(s) or gas supply connection.
3. Do not touch electrical switches or wires.
4. Extinguish any open flame, pilot lights, and all smoking materials.
5. Allow the trailer to ventilate thoroughly. Open all doors, windows, etc.
6. Leave the area until the odor clears.
7. Check all stove valves to ensure they are in the "off" position.
7. Check all appliances to make certain they are off.
8. Have the system checked for leaks by a qualified L.P. service technician following the steps outlined previously.

GAS BOTTLE REGULATOR

The gas bottle regulators are the heart of your L.P. gas system. Regulators are an automatic device with working parts which move continuously. Consequently, they require more care, protection, and attention than any other part of the system. The basic function of a regulator is to take a high and varied inlet pressure from the gas cylinder and reduce it to a safe and consistent outlet pressure to the gas appliances. Whatever the pressure is in the gas bottle, and it will vary due to atmospheric conditions, a low pressure regulator's job is to reduce it to 6.35 ounces or 11" (high pressure regulator 16 p.s.i.) water column outlet pressure, and supply fuel downstream at this pressure in whatever volume is required to efficiently operate each appliance as the demand is made.

The regulators are equipped with a vent because they are constantly "breathing." That is, the diaphragm of the regulator moves down and draws air into the bonnet or adjustment spring housing. When the diaphragm moves up, the air is expelled through the vent. In the event that excess pressure builds up in the lower housing or body of the regulator, a relief mechanism vents it to the atmosphere. For this reason regulators that are not in compartments have been equipped with a protective cover. Make sure that regulator vents face downward and that covers are kept in place to minimize vent blockage that could result in excessive gas pressure causing fire or explosion. It is imperative, therefore, to check the vents frequently to be sure they are clean and free of water,

corrosion, or obstructions as clogging is the most common cause of regulator malfunction. If the vents become clogged, they can easily be cleaned with a toothbrush. In addition, your regulators should be checked periodically by a competent L.P. service technician to be sure that they are properly adjusted and in safe working condition. By following these simple precautions, your regulators will give you years of trouble-free service.

WARNING: If the regulator vent becomes plugged, excessive pressure will cause the appliance to leak, making fire and/or explosion possible and causing subsequent damage to the appliance.

The regulator will function regardless of the position in which it is mounted; however, the recommended mounting position is with the vent vertically down or in a direct line opposite the inlet. If for any reason this is not possible, bear in mind that it is extremely important that the vent be pointed in a direction which results in the least likelihood of dirt, water, or other foreign materials getting into the regulator. It is also important to install the regulator in a position in which the cover cannot possibly become a receptacle for water or other foreign materials.

L.P. GAS REGULATOR FREEZE-UP

A regulator does not freeze, nor will L.P. gas; however, as the gas passes through the regulator, it expands and cools, and moisture in the gas or in the regulator will turn into ice. This ice can build up and totally or partially block the orifice and thus partially or totally block the fuel supply. There are a number of things you can do to prevent this type of freeze-up:

1. Before it is filled, Be sure the L.P. cylinder is totally free of moisture by drying any visible water around the valve area.
2. Be sure the cylinder is not overfilled. Insist that the bottle never be filled beyond 80% liquid level.
3. Keep the valves on an empty cylinder closed.
4. Have your L.P. dealer purge the cylinder if freeze-up occurs.
5. If necessary, have your L.P. dealer inject methyl alcohol in the cylinder.
6. Keep the cylinder in an upright position.

If a gas bottle is overfilled, a built-in pressure mechanism on the bottle will allow excess gas to escape. It is imperative, therefore, that once bottles have been filled that they always be stored outdoors in an upright position whereby complete ventilation is possible. As an example, if a bottle is filled during extremely low temperatures, an increase in temperature will allow the gas to expand and possibly trigger the release valve. The presence of this gas in a confined area could result in fire or explosion caused by exposure to an open flame.

NOTE: Preventive maintenance on all gas appliances should include periodically cleaning as needed to remove dust, lint, etc. from burner tubes and air passages. Burner tubes and orifices should also be inspected frequently for obstructions such as insects/spider webs or other foreign matter that may cause a burner malfunction.

WARNING: The water heater and furnace combustion air exhaust ports may be extremely hot during water heater and furnace operation. Do not touch these outlets or allow any material to come in contact with, or cover, either the air intakes or exhaust ports while operating the water heater and/or furnace.

PROPANE GAS LEAK DETECTOR

The propane you use to cook, refrigerate, and heat with is combustible. Should a leak occur, when the gas reaches the detector in sufficient concentration, your detector will produce a pulsating alarm sound and the RED indicator will flash. This alarm (4 rapid beeps per second) will continue to sound until the gas has dissipated or until the mute button is pressed. When the alarm sounds, follow the eight outlined steps to evacuate the trailer. Do not reenter the effected area until the alarm stops sounding. *If the alarm sounds a second time after the gas is turned back on, leave the gas off and have a qualified Gas Dealer or RV Service Center make the necessary repairs to the source of the gas leak.* The mute button only stops the alarm from sounding for 60 seconds. This detector only indicates the presence of Propane Gas at the sensor. Propane Gas may be present in other areas. This device is intended for detection of Propane Gas leaks ONLY.

WARNING: Do not cover or allow the detector to be obstructed. It may not detect propane gas if obstructed. Exposure of this detector to an intense electromagnetic field may produce unpredictable operation. For example, a radio transmitter in close proximity to the detector may cause the detector to malfunction when the transmitter is transmitting. Failure to comply to these warnings could produce a hazardous condition.

For further details refer to respective appliance manual.

WATER SYSTEMS

Fresh water may be supplied to your trailer sink (and shower unit where applicable) from one of two sources - the water tank or the city water hookup. Fixtures for both of these are located on the roadside body panel and are marked accordingly.

CITY WATER

When the campsite provides a pressurized water system: Remove the protective cap from the external pressure water connector. Attach a non-toxic garden hose (not furnished) between the external trailer connection and the (campsite-furnished) water outlet.

IMPORTANT: Since water pressures at campgrounds vary, we recommend installation of an in-line water pressure regulator (not supplied with trailer) at the water supply outlet. This will protect both the trailer water system and your supply hose from excessively high water pressure.

When the city water is turned on, it will bypass the internal water tank with the exception of the water heater only. In order to be sure the water heater is filled, it is wise to open the hot water faucet slightly to allow the escape of trapped air.

Two types of faucet assemblies are used: Mixer faucets are used when the hot water option is elected. These operate the same as your house-hold hot/cold faucets. Hand pumps are used by turning on and off when a city water hook-up is present. If primitive camping, raise the knob up and down to draw water from the plastic storage tank.

WATER TANK

If the campsite does not provide a pressurized water system, it will be necessary to use the trailer's internal water system. In order to fill the non-removable water storage tank, open the exterior fill spout and slowly fill the tank using a non-toxic hose or appropriate container. Removable five-gallon water storage bottle/s can be removed from inside the trailer and filled at a suitable water filling station.

To ensure complete sanitation of the potable water system, we suggest the following procedure be used on a new system, one that has not been used for a period of time, or one that has become contaminated. Prepare a chlorine solution using one gallon of water and 1/4 cup of Clorox or Purex household bleach (5% sodium hypochlorite solution). Pour one gallon of solution into tank. Complete filling of tank with fresh water. Open the faucet until all air has been released from the pipes and entire system is filled. Pump water up to the sink. Allow to stand for three hours. Drain and flush with potable fresh water. To remove any excessive chlorine taste or odor which may remain, prepare a solution of one quart vinegar to five gallons water and allow solution to agitate in the tank for several days by vehicle motion. Drain tank and again flush with potable water.

Once the internal water system has been cleaned, flushed, and refilled, water can be pumped by raising and lowering the hand pump handle or opening the mixer faucet hot/cold knobs.

SINK DRAIN

The outlet port for the sink drain is located on the same side of the trailer as the sink and the location is identified with a "drain" decal affixed to the body panel. The sink can be drained by simply removing the plastic protective cap from this fitting and allowing the water to flow freely from the sink. Please note that this fitting is threaded to allow the fastening of an adapter or rubber hose in order to drain the sink into a park-provided facility or waste container. (The adapter is contained in the parts package provided with the trailer.)

WARNING: Do not interchange waste system hose and fresh water hose as contamination to the water supply could result.

HINT: To improve drainage, keep auxiliary drain hose as short as possible, and eliminate kinks and twists. Your dealer can also obtain an auxiliary drain hose package which contains a 1 1/4" twelve foot drain line which attaches directly to the sink drain outlet.

12 VOLT ELECTRIC DEMAND WATER PUMP (trailers equipped with hot water only)

The electric pump can be activated for use by pushing the switch button located on the lower galley top. Once the unit is activated, it will automatically switch on and off depending upon water pressure. Instructions for the specific care, use, and service of this component are enclosed with your trailer. This electric water pump is only to be used when a city water hook is not available and water must be drawn from the built-in water storage tank.

IMPORTANT: Do not allow the electric water pump to run when the water system is dry. Subsequent damage to the pump mechanism will result.

NOTE: The electric water pump is equipped with an in-line screen filter which is located on the inlet fitting of the pump. The filter should be cleaned periodically to ensure maximum pump efficiency. Contact your dealer for the removal of the filter and screen.

HOT WATER SYSTEM (where applicable)

The hot water system in your trailer is a high-quality, versatile system. To acquaint you with the various methods of operation, a discussion of each follows:

METHOD 1:

Connect a garden hose (not furnished) to the campground-provided water outlet and city fill fitting on the roadside body panel of the trailer. Turn the city water supply "on" and allow the system including the hot water tank to fill. Light the water heater by following the instructions printed inside the vent cover.

IMPORTANT: Be certain that the water heater is filled prior to lighting to prevent appliance damage. To ensure the hot water heater is completely full, open the hot water faucet knob on the mixer faucet until water is drawn.

Simply turn the sink or shower faucet knob approximately 1/4 turn to draw water.

METHOD 2:

Fill the plastic water tank. Connect trailer exterior power cord to 110 VAC power supply. Engage the electrical demand pump by pressing the switch button located on the lower galley top. Once the hot water tank is filled and all faucets closed, the pump will automatically shut off. Light the water heater by following the instructions printed inside the vent cover. Simply turn the sink or shower faucet knob approximately 1/4 turn to draw water. The electric pump will automatically engage to provide needed water pressure. Due to the water draw during filling of the hot water heater, it will be necessary to refill the plastic water tank.

WARNING: The hot water drawn at the faucets is directly out of the water heater. The temperature of the water could be as high as 150°. Scalding could occur if the hot water is not diluted. **DO NOT** expose the body directly to the undiluted hot water. Also, hydrogen gas can be produced in a hot water system served by this heater that has not been used for a long period of time (generally two weeks or more). Hydrogen gas is extremely flammable. To reduce the risk of injury under these conditions, it is recommended that the hot water faucet be opened for several minutes at the sink before using any electrical appliance connected to the hot water system or lighting any gas appliance. If hydrogen is present, there will probably be an unusual sound such as air escaping through the pipe as the water begins to flow. **THERE SHOULD BE NO SMOKING OR OPEN FLAME NEAR THE FAUCET AT THE TIME IT IS OPENED.**

When a 110 VAC power supply is not available, your water system may be used by connecting the trailer 12 VDC power supply to a tongue-mounted battery or tow vehicle 12 volt outlet, i.e. cigarette lighter.

IMPORTANT: Never attempt to light the hot water heater if it is not filled. Permanent damage to the heater unit could occur and such damage would void the warranty.

DRAINING AND WINTERIZING WATER SYSTEM

Your dealer can advise you concerning specific winterization procedures and products for your climate area or the areas through which you will be traveling. Your dealer may also provide winterization service for all appliances and systems in the trailer. If you choose not to travel during the winter and will be storing your trailer during periods of freezing temperatures, follow a thorough winter storage procedure. Protecting the plumbing systems in your trailer is the most important aspect of long-term winter storage. Extensive damage to the plumbing fixtures and components as well as other potential problems can be avoided by proper draining and antifreeze protection. Following are procedures for winterizing your vehicle yourself.

On units not equipped with a hot water heater or tub and shower unit, the water system may be drained by simply turning the petcock located on the bottom of the water storage tank under the trailer and allowing all water to drain out. Use the hand pump to drain remaining water out of the lines once the tank is drained.

On those units equipped with portable water bottles and not a built-in water tank, it is only necessary to drain the lines and simply empty the bottles.

Drain the fresh water tank by opening the water tank drain valve. Leave valve open. Turn the electric water pump on (12 volt DC power on). Open a cold water faucet. When the flow of water stops, turn the pump off. After opening hot and cold water faucets, open the drain valves on HOT and COLD water pipes. These valves are located on the underside of the trailer. (Water line drain valves only applicable in trailers so equipped.) Drain the water heater by opening the drain valve at the bottom of the heater and open the safety valve. Open the hot water faucets. (Reference water heater instructions for exact location of drain valve.) When each faucet has been opened, drained, and closed, close the water line drain valves and freshwater tank drain valve. Disconnect the shower hose assembly. Be sure ALL water from ALL plumbing fixtures has been drained.

IMPORTANT: Draining the water system alone will not provide adequate cold weather protection. If the trailer is to be unheated during freezing temperatures, consult your dealer for the best winterizing procedure for your climate. Your dealer can winterize your trailer for you or can supply you with one of the special antifreezes which are safe and approved for use in RV water systems. Follow the instructions furnished with the antifreeze.

WARNING: Do not use automotive or windshield washer antifreeze in the trailer water system. These could be harmful if swallowed.

Pour approximately two gallons of non-toxic R.V. approved antifreeze into the portable or built-in water tank. Be sure tank drain valve is closed. Turn the 12 volt water pump switch "ON". Open each cold water faucet, run the water pump and let about a cup of antifreeze solution flow continuously through each faucet. Close each cold water faucet. Check the antifreeze level in the water tank. Add antifreeze solution if necessary.

On trailers equipped with a hot water heater bypass, turn the water pump switch "OFF". Completely drain water tank and water heater. Open water heater relief valve to drain water heater. Pour approximately two gallons of non-toxic RV-approved antifreeze into portable or built-in water tank. Open all hot and cold water faucets to relieve pressure. Close all faucets. Install water heater bypass connection. This can be achieved by disconnecting the two swivel elbow connections from the back of the hot water heater, (hot & cold lines). Attach bypass line

onto the two swivel connections. Turn water pump "ON". Open hot water faucet farthest away from water tank. When antifreeze appears, let about one cup run down drain to winterize trap, then close faucet. Repeat this at all other hot and cold water faucets including the shower. Turn water pump OFF. Open water faucet to relieve pressure then close. Winterizing of the fresh water system is complete.

When filling the plumbing systems with antifreeze, be sure to open and operate all fixtures and valves allowing the antifreeze solution to flow freely. Pour a cup of antifreeze solution down each sink and tub drain. Install all protective caps: water tank fill, city water inlet cap.

TRACKING SYSTEM

TIRES

PLEASE NOTE: While the warranties of the various tire manufacturers vary in language, they provide that tires installed as original equipment at the factory are warranted to the owner to be free from defects in material and workmanship for one year after the retail sale or 33% of the tread wear, whichever occurs first. There is no warranty coverage for damages resulting from road hazards, improper inflation pressures, driving more than the maximum speed limit, or overloading the trailer beyond the maximum load capacity.

CAUTION: To provide maximum towing ease, tire life, and trailering safety, check the following items before each trip to and from the campsite:

1. Tires inflated to recommended pressure as indicated on the tire sidewall.
2. Wheel lugs securely tightened (50-75 foot-pounds for 12" tires; 90-120 foot-pounds for 13" tires).
3. A visual inspection of tire tread and side walls for wear or cuts.
4. Trailer is being towed as level as possible with tow vehicle (at all times).
5. Trailer cargo does not exceed maximum weight limits (GVWR, GAWR, GCWR). Refer to trailer weights.

If a tire warranty adjustment is required, the trailer owner should contact the nearest authorized Fleetwood folding trailer dealer. In the event there is no local dealer, the customer should follow the directions set forth in the tire warranty card packaged in each folding trailer. A Fleetwood folding trailer dealer MAY be able to assist you in handling warranty adjustments.

NOTE: Not all Fleetwood folding trailers are capable of accepting different size tires. Prior to making any tire size changes, consult your dealer for tire size adaptability.

HOW TO CHANGE A FLAT TIRE

Tires can be changed using the following procedure. For safety purposes, turn on the vehicle hazard warning flashers. Block both front and back sides of the tire opposite the one needing changing. Remove the hubcap from the tire you wish to change. Using a 13/16" lug wrench (not supplied), break loose the lug nuts. Raise the trailer using a scissor or hydraulic jack. **Do not utilize the stabilizer jacks as a means of lifting the trailer weight.** The jack should be placed directly underneath the main frame bar and **NOT** on the axle beam. Take the lug nuts off using the lug wrench. Slide the flat tire off and slide repaired, new, or spare tire onto the axle. Start each lug nut by hand to avoid cross-threading and then use the lug wrench to draw the lug nuts reasonably tight. Lower the jack until the tire is on the ground. Using a lug wrench, draw the lug nuts tight (50-75 foot-pounds for 12" tires; 90-120 foot-pounds for 13" tires). Replace hubcap.

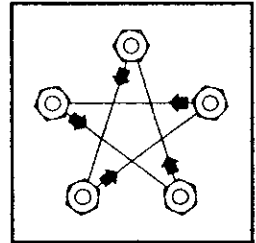

Torque Chart

CAUTION: After you have driven a short distance (approximately one or two miles), stop and recheck the lug nuts to ensure they are properly torqued. Check again after 10, 25, and 50 mile intervals.

BRAKES (where applicable)

Brakes should be adjusted after the first 200 miles and at 3,000 mile intervals, or as use and performance requires. For brake adjustment and maintenance, please refer to Electric Brake Manual supplied in the trailer information packet.

BREAKAWAY SWITCH (where applicable)

The breakaway switch is located on the trailer tongue. It has a steel cable (lanyard) fastened to it which will reach to the frame of the tow vehicle. This device is one of the most vital components on your trailer's braking system. It automatically applies the trailer brakes if the tow vehicle and trailer become uncoupled while in motion. The breakaway switch operates when a pull pin linked by the cable to the tow vehicle is separated from the switch. When the switch closes, power for brake application is transferred from the auxiliary trailer battery. The steel lanyard must be anchored to the tow vehicle when the trailer is hitched up. Secure this cable loop to the permanent frame of the tow vehicle or a part of the hitch that is non-removable. **Do not fasten the breakaway switch lanyard to the hitch ball or any other removable part of the hitch.** Remove the pull pin every three months and lubricate it with light oil. Before reinserting the pin, spray the inside of the switch with an electrical contact cleaner to prevent corrosion.

Test the breakaway switch operation before each trip as follows:

1. Hitch the trailer to the tow vehicle.
2. Pull out the breakaway switch actuating pin.
3. Test brakes by attempting to drive away. The breakaway switch is functioning properly if the trailer brakes are activated.
4. If the brakes are not activated, check that the trailer battery is connected and fully charged and the trailer brakes are properly adjusted.
5. Obtain service repair if the trailer brakes do not operate after making these checks.
6. Reinsert the breakaway switch actuating pin before towing the trailer.

WARNING: Do not tow a trailer with a malfunctioning breakaway switch and do not leave the pull pin out of the breakaway switch for more than a few minutes or the battery will be drained. Do not use the breakaway switch as a parking brake.

BALL HITCH AND COUPLER

All trailer models are equipped with a 2" ball coupler. (Maximum vertical load 350 lbs. - class 2)

Maintain a coat of light grease on the ball hitch of your vehicle. This will induce longer ball hitch life and towing ease. The coupler should be adjusted, when required, to maintain the coupler/ball snugness. With the coupler attached to the ball and the coupler release handle down in the locked position, adjust the lock nut (on the underside of the coupler) to compress spring to within 1/32" of solid. Make a visual inspection of the safety chains for damaged or corroded links; repair or replace as required. Ensure the ball hitch is securely attached to the vehicle and the ball head is securely tightened.

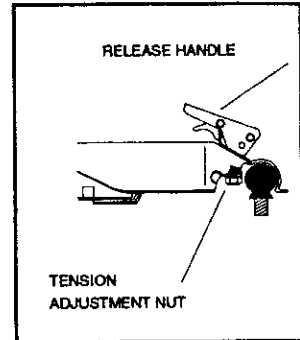

Coupler

RECOMMENDED PRACTICES FOR LUBRICATING AND ADJUSTING WHEEL BEARINGS

IMPORTANT: Wheel bearings should be checked before the initial camping trip and then every 5,000 miles or at the beginning of each camping season.

LUBRICATION

Re-lubrication of wheel bearings is the most important service performed to the running gear. The two most important phases of this operation are cleanliness and proper adjustment. Before disassembly of the hub, check wheel play and freedom of rotation. Extreme or excess play indicates a too-loose adjustment or a defective bearing. Too much drag in rotation of the hub could indicate tightness in bearing adjustment or a brake being adjusted too tight. To begin disassembly, remove the dust cap. Next, remove the cotter pin and spindle nut. Jiggle the hub slightly to loosen the outer bearing. Usually the outer bearing will loosen up enough to be removed by hand. Pull the entire hub which contains the inner bearing and grease seal. Remove the inner bearing by using a seal puller to remove the inner grease seal. Be sure not to damage the bearing case while removing the seal. Wipe all dirt and grease from the inside of the hub and the spindle.

Used bearings must be cleaned prior to lubrication. Various solvents are effective for degreasing. Successful processes employ kerosene, distillates, and chlorinated hydro-carbons. The solvent action of kerosene is limited, but it has the advantage of leaving a rust-inhibitive film on the bearing. After cleaning, bearings should be allowed to drain free of solvent which might dilute lubricants. It is not recommended to reuse grease seals once removed. New grease seals should be installed when repacking wheel bearings.

WARNING: Do not use above-described cleaning solvents near or around open flames as fire or explosion could occur resulting in serious bodily injury.

Carefully inspect races and bearings for pitting, scratches, excessive wear, or other damage. Do not replace a bearing unless you also replace its mating race cup.

If at all possible, use a bearing packer to repack the roller cones. Using a high temperature wheel bearing grease (Type NLGI#2), the bearings can be lubricated by hand if the grease is pressed into and around each and every roller cone. Additional grease within the hub is not required. Install the inner bearing in the hub and replace grease seal by tapping gently with a wooden block, making sure the seal is installed as it was before disassembly. Replace hub on spindle, taking care not to damage threads or grease seal. Replace outer bearing and spindle nut. Slowly rotate the hub in one direction or the other while tightening the spindle nut (maximum 50 foot-pounds torque) or until there is a slight bind to be sure that all bearing surfaces are in contact. At this point the adjusting nut is backed off 1/6 to 1/4 turn or to the nearest locking hole or castellation. This will allow the wheel to rotate freely without excessive end play. By pushing inward and pulling outward on the hub several times a person should feel a very slight end play. If the bearings are too tight or too loose, they will fail prematurely. Install new cotter pin, bend to locked position, and drive on grease cap. Damage to the grease cap could cause the cap to disengage while traveling.

LIFT SYSTEM

Never crank the trailer up with weight on the roof except for a dealer-installed air conditioning unit. Additional weight placed on the top assembly while the unit is being cranked up can result in an unnecessary strain on the lift system causing cables to be stretched and the loss of proper roof height adjustment. Never raise or lower the roof with the stabilizer jacks set. This action can cause a bind on the trailer frame resulting in excessive pressure being placed on the four lift assemblies and pulleys. (Maximum combined weight of roof-mounted accessories is 150 pounds with the top open.)

MAINTENANCE

The maintenance that will be necessary to perform to your lift system is an occasional lubrication of the pulleys contained within the lift system and periodic lift height adjustment. Lubrication should be only a silicone spray and used very sparingly.

NOTE: Excessive lubrication on the pulleys or lubrication on the outer face of the lift arms can result in unsightly stains to the tent enclosure.

TOP ADJUSTMENT

Height adjustment, if necessary, can be performed at each main cable adjustable pulley bracket. One bracket is located in each corner of the main frame tube area.

Crank top to approximately 12" high. Extend front and rear bed assemblies approximately one foot past body rails. Lower top down on extended beds until crank stops to relax cables. Remove pulley pin and relocate pulley to an alternate hole position. (Each hole should add about 1 1/2" lift height to that particular corner. Do not over-adjust or tenting and weather seals may be damaged or pull out of the retaining track.) Raise top and return beds to travel position.

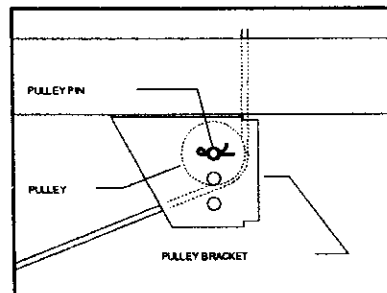

Adjustable Pulley

NOTE: Top height adjustment is considered routine maintenance and is not covered under normal trailer limited warranty.

NOTE: Fine adjustments can only be performed at the main drive train area. This adjustment should be performed by an authorized Fleetwood folding trailer dealer.

IMPORTANT: We emphasize that any customer repairs to the lift system should only be done as a temporary measure. Your dealer should be consulted prior to performing any lift system service to prevent inadvertent damage to the system.

TENT ENCLOSURE

CLEANING

The tent enclosure should be cleaned regularly before substances such as dirt are allowed to accumulate and become embedded in the fabric. The fabric can be cleaned without being removed from the trailer. Simply brush off any loose dirt. Hose down and clean with a mild solution of natural soap such as Lux or Ivory in lukewarm water (no more than 100 degrees F). Rinse thoroughly to remove soap.

NOTE: DO NOT USE DETERGENTS.

If the fabric indicates slight water leakage as a result of residual soap, repeat rinsing. A second alternative is to treat the fabric with a water repellent such as 303 High Tech Fabric Guard or 3m Scotchgard Fabric Protector (red plaid can only).

IMPORTANT: The tent fabric should always be dry when closing or storing the trailer. If the trailer must be closed with the tent fabric wet, for example breaking camp during rain, it is of utmost importance to open the trailer as soon as possible to allow the tent fabric to dry. This will prevent mildew growth which can occur on dirt or other foreign substances not removed from the tent fabric.

NOTE: All washing of tent enclosure material is the consumer's responsibility and is not covered under the normal trailer limited warranty.

CONDENSATION PREVENTIVE MAINTENANCE

The relatively small volume and compact construction of a modern recreational vehicle mean that the normal living activities of even a few occupants will lead to rapid moisture saturation of the air contained in the trailer and the appearance of visible moisture, especially in cold weather. The air inside a recreational vehicle can contain a surprisingly large amount of water vapor. Estimates indicate that a family of four can vaporize up to three gallons of water daily through breathing, cooking, bathing, and washing. Unless this water vapor is carried outside by ventilation, it will condense on the inside of the tent enclosure as moisture. If you know the signs of excessive moisture and condensation, you can minimize their effects during cold weather by the following:

1. Ventilate with outside air. Partially open one or more windows to provide controlled circulation of outside air into the interior. While this ventilation will increase furnace heating load, it will greatly reduce or eliminate water condensation. Even when it is raining or snowing, ventilation air from outside will be far drier than interior air and will effectively reduce condensation.

2. Provide more ventilation while cooking is being done inside the camper.
3. Ensure adequate ventilation in areas where condensation problems are experienced.
4. The use of an electric circulating fan or a small dehumidifier inside the camper will noticeably reduce condensation.

VINYL BED END COVERS

The exterior vinyl over the bed areas can be cleaned by using cool water and a soft bristle brush or cloth. Rinse thoroughly with cool water and allow to dry. When necessary, automobile convertible top cleaners can be used to remove stains.

IMPORTANT: Care should be taken not to allow the vinyl cleaner to come in contact with the tent material or tent leakage may result. Follow the manufacturer's instructions carefully for use of such cleaners or damage to the vinyl surface could occur. Direct contact of insect repellents, hair sprays, and/or suntan lotion/oils on the tent surfaces will cause a breakdown of the water repellency of the fabric. Care should also be used around drapes and privacy curtains. Some cleaners will stain or fade the fabric.

The zippers on your tent can be lubricated by using a paraffin wax. The use of paraffin on the zippers will enhance their ease of operation around the tent sections and windows.

MATTRESS CARE

For cleaning dirt and stains from the mattress fabric, follow the outlined procedures below:

1. Remove loose dirt with a soft brush or compressed air.
2. Cleaning solution: 5% Dawn dish washing detergent and 95% water.
3. Wet area using spray bottle set to medium spray.
4. Spray directly on spot but do not saturate fabric.
5. Immediately blot or wipe dry with handi-wipe or soft sponge. Use of foam rubber not recommended.

ROOF-MOUNTED ACCESSORIES

Periodic maintenance should be performed to all roof-mounted accessories. Check all sealant of accessory attachment points to roof assembly. Cracks or voids in sealant can lead to water damage to roof and interior trailer components.

CAUTION: Do not exceed 150 pounds of roof-mounted cargo/weight while raising and lowering the top assembly. Exceeding this weight limit could damage the lift system.

ROOF-MOUNTED AIR CONDITIONERS

An optional roof-mounted air conditioner can operate only when the trailer is connected to 110 VAC power from either a public utility or a generator. Routine maintenance for a roof-mounted air conditioner should include inspecting the ceiling assembly attachment bolts after each trip to ensure the bolts have not loosened or backed-out due to road vibration. For further maintenance on your air conditioner, follow the manufacturer's recommendations as outlined in the air conditioner owner's manual.

CAUTION: Do not place a tarp over the "A.B.S." top assembly. Excessive heat and moisture build-up can cause irreversible damage to the trailer component parts.

ELECTRICAL

When the campsite provides an electrical system: Plug the power cord into the campsite-provided 110 volt outlet (30 amp. service U.S.).

WARNING: The electrical system is rated for a maximum (30 amp USA/15 amp CSA) A.C. current. Be sure not to exceed this rating. Excessive amperage draw could cause electrical system problems. Be sure any outlet the trailer is plugged into is grounded and has the correct polarity.

CONVERTER

The 6700 series converter changes the 110 volt park supply to 12 VDC for operation of the interior 12 volt lights and certain 12 volt appliances (i.e., furnace). This 12 VDC is a filtered voltage and may be suitable for use with appliances such as radios or television monitors. The receptacles inside the trailer carry the 110 volt current for operation of 110 volt appliances and the like.

When the converter is "unplugged" from the 110 volt park supply, the interior electrical lights and appliances must be serviced by an external 12 volt battery for the electrical supply. This external battery could be the tow vehicle battery or an auxiliary battery mounted on the tongue of the trailer.

All converters will switch from AC to DC automatically and will not have a manual changeover switch.

If the converter is not plugged into a 110 VAC source, the 110 VAC outlets within the trailer will not operate.

All 6700 series converters contain a charge unit within the converter. Therefore, it is recommended during long periods of non-use that the trailer be plugged into a 110 VAC source over night to maintain the battery charge. Always follow the converter manufacturer's recommendations. Do not accidentally switch battery polarity at the terminals.

If the converter output is overloaded, the converter has a built-in temperature protection circuit which will shut

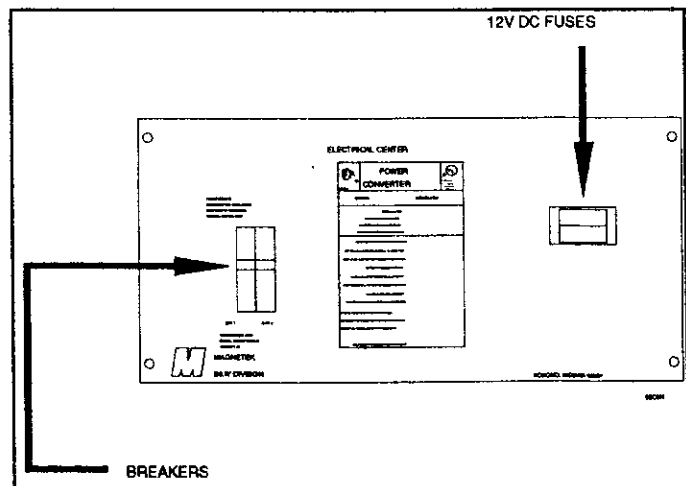

Trailer Converter

down the converter. Once the converter cools (approximately one minute) the converter will then reset and supply output. A fuse may also fail if overloaded. If the converter continues to shut-down, the overload condition must be corrected before normal operation of the converter will resume.

NOTE: For additional information on the converter contained within your trailer, refer to the converter operation manual in your trailer literature package.

WARNING: Do not use or store a battery inside the trailer. Battery acid leakage or explosion could cause bodily injury or death.

On the tongue of the trailer are two 12 volt DC wiring harness connectors. The main harness is a male connector which connects to the tow vehicle for the operation of running lights, brake lights, and so forth. Each model also has a two-prong female connector which is for the auxiliary battery operation of the 12 volt interior lighting system and optional equipment on battery. In order to use the two-prong receptacle, it is necessary to purchase the 12 volt auto extension cord or battery mount kit from your dealer. This cord may be plugged into the tow vehicle cigarette lighter or to an auxiliary battery to provide 12 volt power to the interior of your camper.

IMPORTANT: All gas leak detectors must be connected to a constant 12 volt power source at all times to operate. During periods of non use, the tow vehicle or auxiliary trailer battery should be disconnected. Otherwise, the gas leak detector will drain the battery.

CAUTION: Ensure interior top lights are turned to the "OFF" position when closing the trailer in the travel position.

The electrical system of your folding trailer is broken down into two separate and distinct functions - the 12 volt direct current and 110 volt alternating current.

12 VOLT VEHICULAR ELECTRICAL CIRCUIT

The 12 volt DC electrical circuit is dependent on the tow vehicle's battery or an auxiliary battery. Frequent and regular checks of the battery should be made to assure electrical system stability. We suggest the following checks:

1. Battery terminals and posts free from corrosion.
2. Battery terminals securely fastened to the battery posts.
3. Battery water level.
4. Battery voltage at the level specified by the battery manufacturer.
5. Recharging battery over night once a month. (Ensure adequate ventilation.)

Before each trip, make an operational check of all DC electrical functions of the trailer: turn, stop, side marker, and taillights. If a bulb does not light, remove the lens cover from over the bulb not functioning. Most often, bulb replacement will cure the malfunction; however, should the malfunction persist, contact your authorized Fleetwood folding trailer dealer or a qualified electrician.

All model trailers are equipped with a 12 VDC in-line kill switch. This switch is located on the lower galley top. When the galley is raised to the upright position, the switch will activate thus allowing power to be supplied to the interior top lights. Shower equipped trailers have an ON/OFF switch located on the lower galley top to turn the 12 volt electric pump on and off. Tip-out galleys and glide-out dinette areas have an auxiliary 12 volt plug installed on the interior of the top for attachment of additional 12 volt light fixtures.

110 VOLT AC POWER SUPPLY

The 110 volt AC power cord can be plugged into a park supply power source for the operation of interior and exterior receptacles only. The converter will change the 110 volt AC park supply to 12 volt DC current for interior lighting and optional equipment operation. Two AC circuits are available, a 15 amp circuit which incorporates the G.F.I. receptacle, one or two regular outlets, and a 20 amp circuit which is for air conditioner hook-ups. All 20 amp circuits can be identified by a horizontal notch on one of the vertical receptacle legs. All Canadian trailers utilize 15 amp circuits only.

NOTE: Certain models also have a 20 amp G.F.I. receptacle where applicable.

All model trailers are equipped with a 110 volt AC exterior outlet for your convenience. This outlet is wired in series with a Ground Fault Interrupter. This device is intended to protect you against the hazards of line to ground electric faults and electrical leakage shocks. Materials used to insulate appliances and devices can deteriorate over time or develop cracks or weak spots that could allow electric current to "leak" through the insulation. Should a circuit or appliance develop a potential shock hazard of this type, the GFI device is designed to disconnect the outlet (and other outlets on the same circuit), limiting your exposure time to the shock hazard caused by current leakage to ground.

The GFI device does not prevent electric shock, nor does it protect a person who comes into contact with both "hot" and neutral sides of the circuit. It does not protect against electrical circuit overloads. Test the GFI at least once a month while operating on 110 volts AC. To test the GFI:

- * Push the "TEST" button. The "RESET" button should pop out, indicating that the protected circuit has been disconnected.
- * **IF THE "RESET" BUTTON DOES NOT POP OUT WHEN THE TEST BUTTON IS PUSHED, A LOSS OF GROUND FAULT PROTECTION IS INDICATED. DO NOT USE THE OUTLET OR OTHER OUTLETS ON THE SAME CIRCUIT. HAVE THE TRAILER ELECTRICAL SYSTEM CHECKED BY AN AUTHORIZED FLEETWOOD FOLDING TRAILER DEALER OR BY A QUALIFIED ELECTRICIAN. DO NOT USE THE SYSTEM UNTIL THE PROBLEM HAS BEEN CORRECTED.**
- * To restore power push the "RESET" button.

NOTE: If a 110 volt outlet doesn't work, check the GFI or circuit breaker (15/20 amp). Reset it if necessary. If the GFI continues to trip, have the trailer electrical system checked at an authorized Fleetwood Folding Trailer Dealer or by a qualified electrician.

NOTE: Due to the variety of interior floor plans, the GFI receptacle may be placed in different locations from one model to another.

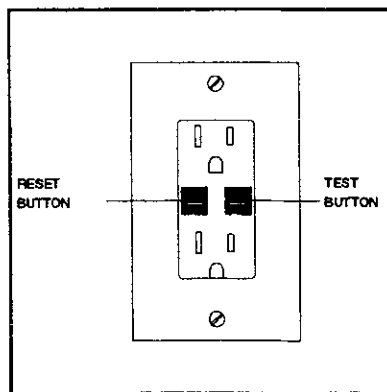

GFI Receptacle

12 VOLT EXTERIOR WIRING COLOR CODE

GREEN - TAIL, TAG, MARKER
 WHITE - GROUND
 RED - LEFT TURN AND STOP
 BROWN - RIGHT TURN AND STOP
 BLUE - ELECTRIC BRAKES
 BLACK - AUX. 12V
 BLACK/RED TRACER - AUX. 12V

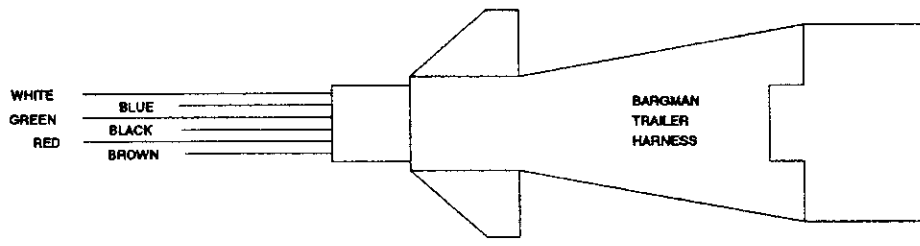
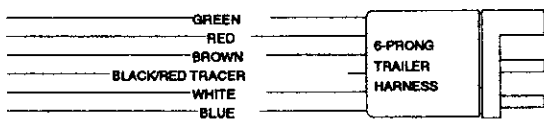
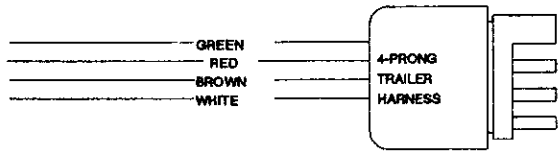

MAINTENANCE CHART

NOTE: SERVICES ARE TO BE PERFORMED AS NOTED IN THE HIGHLIGHTED AREAS.

BEFORE EACH TRIP	EVERY TWO MONTHS
Inspect safety chains	Inspect exterior roof sealants
Inspect trailer/tow vehicle wiring connections	ANNUALLY OR BEFORE LONG-TERM STORAGE
Inspect hitch components	Lubricate lift arm pulleys
Test break-away switch	Winterize water system and drains
Inspect tires for wear	Lubricate glide-out compartment track and rollers.
Check tire pressure	Disconnect battery (where applicable)
Check wheel lug nut torque	Ensure tenting fabric is dry
Check exterior lighting	ANNUALLY OR AFTER LONG-TERM STORAGE
Inspect LP gas components	Lubricate bed slides/rollers
Inspect A/C ceiling assembly bolt tightness	Inspect brakes/Adjust X
Re-charge battery (where applicable)	Sanitize fresh water tanks/cassette potty
MONTHLY	Lubricate coupler and latch
Inspect and clean battery, cables and terminals	Complete LP gas pressure and system check X
Check fire extinguisher	Repack wheel bearings (every 5000 miles) X
Test GFI	AS NEEDED
Wash exterior (trailer closed)	Clean tenting
Inspect and clean water pump filter	Clean interior
Re-charge battery (where applicable)	Lubricate door latches and locks

"X" Indicates items that should be performed by qualified personnel with appropriate equipment.

MAINTENANCE CHART

STANDARD CARE ITEMS AND RECOMMENDED CLEANING AGENTS

Stove and sinks	Appropriate household cleaners
Counter tops	Warm soapy water
Bathub	Non-abrasive household cleaner
Cooler/refrigerator	Mild soap and water
Drapes and valances	Hand wash with luke warm water
Mattress covers	5% Dawn dish washing liquid and 95% water; immediately blot or wipe dry
Cushion/backrest covers	Foam type cleaners and vacuum
Table top	Damp cloth
Vinyl windows	Warm water and mild detergents
Vinyl floor covering *	Water and mild soap
ABS panels	Mild soapy water
ABS tops	Formula 409, Windex, Fantastik

*To keep your vinyl floor covering looking new, it is advisable to place a throw rug or carpet on the floor covering directly underneath the area in which the galley will rest during transit.

WINTER/OFF-SEASON STORAGE

When storing your Fleetwood Folding Trailer for extended periods of time, the following steps should be observed:

1. Winterize water system and turn off L.P. gas at tank valve.
2. Angle trailer tongue end slightly downward to eliminate water, snow or ice build-up on top assembly. Snow or ice build-up on the top assembly should be removed as soon as possible.
3. If trailer is equipped with roof mounted accessories, open bi-monthly to ensure all accessory seals are functioning.
4. DO NOT cover trailer "A.B.S." top assembly with a tarp. Lack of air circulation within a closed trailer can lead to excessive condensation build-up and mildew. Bubbling, blistering, etc. can also occur to "A.B.S." tops due to extreme heat build-up under the tarp.
5. DO NOT store trailer in tall grass, weeds or near wood piles.
6. Disconnect auxiliary 12 volt tongue-mounted battery or periodically recharge once a month.

FLEETWOOD FOLDING TRAILER LIMITED WARRANTY

SUMMARY OF WARRANTY

Limited Lifetime Warranty:

Fleetwood Folding Trailers extends to the original retail purchaser a limited lifetime warranty against functional defects in material and workmanship on the lift system, floor wood, bed wood, trailer frame, and the one piece seamless ABS roof. This warranty covers parts, labor and freight for year one; parts and labor only are covered for year two and thereafter. The floor/bed wood warranty applies only to the structural integrity of the wood.

All hydraulic components are warranted against defects in material and workmanship for a period of two years; parts, labor and freight are covered for year one, parts and labor for year two.

Five (5) Year Limited Warranty:

A five year limited warranty against functional defects in material and workmanship applies to the Sunbrella 302 tent material and the aluminum roof. This warranty covers parts, labor and freight for year one; parts and labor only are covered for years two through five.

All other trailer components are warranted to the original purchaser for a period of one year against functional defects in material and workmanship. Parts, labor and freight are covered for these components.

During the specified times, any defective parts in a Fleetwood folding trailer will, at Fleetwood's option, be either repaired or replaced on an exchange basis with new or reconditioned parts. This Warranty does not cover the expense to take the folding trailer to the dealer for repair, nor the return expense. The consumer must pay all expenses incurred in obtaining warranty performance other than those specifically provided for in this Warranty.

This warranty is to the original purchaser and is not transferrable.

The date of retail sale is established by the Warranty Registration.

Replacement parts are warranted for the unexpired duration of the original warranty.

To obtain warranty performance: Consult the yellow pages of the telephone book under "Recreational Vehicle Dealers" for the name, address, and telephone number of the nearest authorized Fleetwood folding trailer dealer; or call Fleetwood Folding Trailers, Inc. at 814/445-9661. (Collect calls will not be accepted.) Call the authorized Fleetwood folding trailer dealer, report the problem and schedule an appointment. Take the trailer at the scheduled time to the dealer along with the owner's card sent to you by Fleetwood. Only authorized Fleetwood folding trailer dealers may perform warranty obligations. The authorized Fleetwood folding trailer dealer will advise when the warranty performance has been completed. All payments for warranty service and for parts will be made by Fleetwood to the dealer and not to the consumer.

General exceptions and exclusions are outlined on the following page.

LIMITED WARRANTY GENERAL EXCEPTIONS AND EXCLUSIONS

To the extent any or all of the following exclusions or provisions of this warranty are prohibited by any federal, state, or municipal law which cannot be preempted, those exclusions or provisions shall not be applicable.

THERE ARE NO OTHER EXPRESS WARRANTIES EXCEPT THOSE NOTED IN THE SUMMARY OF WARRANTY SECTION OF THIS MANUAL AND ANY IMPLIED WARRANTIES, INCLUDING THE IMPLIED WARRANTIES OF MERCHANTABILITY AND FITNESS FOR A PARTICULAR PURPOSE, ARE LIMITED IN DURATION TO THAT OF THE EXPRESS WARRANTY. Some states do not allow limitations on how long an implied warranty lasts, so the above limitation may not apply to you.

The installation of any roof-mounted accessories exceeding 150 pounds, alterations to the lift system, any damage caused by improper maintenance, improper repair, or the use of improper repair parts are not covered under this warranty. The lifetime warranty provisions do not include exterior surface finish, frame paint, axle beam, springs, running gear components, bed extensions, bed frames, damage due to installation of non-standard roof equipment, or exceeding the recommended top/trailer cargo limits.

Any cosmetic and non-functional defects not noted prior to retail delivery are not covered under this warranty.

Any unauthorized repairs.

Damage caused by failure to perform normal and routine maintenance as set out in the folding trailer owner's manual, mishandling, neglect, abuse, misuse, lightning, or corrosive atmospheres are not covered by this warranty.

This warranty shall not apply if the serial number plate is removed or defaced.

The ABS roof is not warranted against discoloration or damage due to the use of improper cleaning agents. Deflection of the ABS roof materials associated with normal expansion and contraction or the addition of roof-mounted accessories is not covered under this warranty.

The tent material is not warranted against fading, discoloration, or soiling. Rips and tears not noted prior to retail delivery are not warranted.

Vinyl floor covering gouges, cuts, or tears, not noted prior to retail delivery, are not covered under this warranty.

The water heater, cassette potti, furnace, and refrigerator, in trailers so equipped, are warranted by their respective manufacturers. A copy of the warranty for each of these components is provided with the folding trailer. The light bulbs, fuses, tire valve cores, and other similar items are not covered by this warranty and are sold AS IS.

Trailers used for rental purposes are covered by this warranty for three (3) months from the date of purchase by the rental dealer; or if rented by an authorized Fleetwood folding trailer dealer, from the date of rental registration.

This warranty applies only to products sold at retail in the United States and Canada.

Fleetwood Folding Trailers, Inc. reserves the right to make changes in the design or material of its product without incurring any obligation to incorporate such changes in any product previously manufactured.

THIS WARRANTY DOES NOT COVER CONSEQUENTIAL DAMAGES OR CHARGES, such as extra expenses for transportation to and from the dealer or manufacturing plant location, loss of time, loss of pay, loss of use of the folding trailer, inconvenience, commercial loss, towing charges, bus fares, vehicle rental, incidental charges such as telephone calls or lodging bills, or other INCIDENTAL CHARGES, DAMAGES, OR EXPENSES INCLUDING DAMAGE TO PROPERTY (other than injury to person). Some states do not allow the exclusion or limitation of incidental or consequential damages, so the above limitation or exclusion may not apply to you. This warranty gives you specific legal rights, and you may also have other rights which vary from state to state.

CHANGE OF OWNERSHIP NOTIFICATION

If you are the second or subsequent owner of this folding trailer, it is important that you notify Fleetwood Folding Trailers of your name, address, and the Serial Number of your trailer. This information is vital for Fleetwood Folding Trailers to maintain up-to-date records of current ownership. Please complete the form below, clip it, and mail it to:

Fleetwood Folding Trailers, Inc.
258 Beacon Street, P.O. Box 111
Somerset, Pennsylvania 15501

MODEL INFORMATION

Year _____ Model _____

Trailer Serial No. _____

NEW OWNER INFORMATION Purchase Date _____

Name _____

Address _____

City _____ State _____ Zip _____

Name of Previous Owner _____

Coleman and the Coleman Parallelogram are registered trademarks of the Coleman Company, Inc., used under license.