

FLEETWOOD

FOLDING TRAILERS

1995 OWNER'S MANUAL

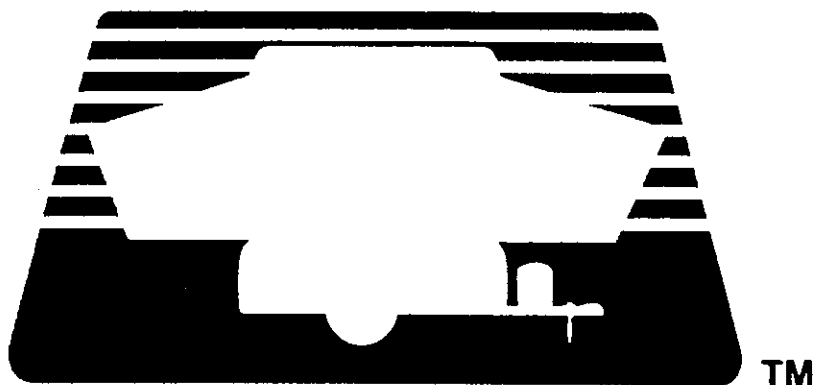

**EXPERIENCE
AMERICA'S BEST**

TO OUR VALUED CUSTOMER:

It is our pleasure to welcome you to our Fleetwood owner's family. Your new Fleetwood folding trailer was designed by a team of specialists who are dedicated to making your camping experience one of the most memorable times of your life.

For over 40 years Fleetwood, as the world's largest manufacturer of R.V.s, has built a solid reputation of providing quality products with features that offer safety, comfort, convenience, and value. Today, as well as in the future, no matter where you travel you will find that Fleetwood and our Fleetwood dealer network will be there to serve your needs.

You will be glad you chose a folding trailer by Fleetwood - The Number One Brand Folding Trailer in the World! We thank you for the confidence you have placed in our company and our products, and we will do everything possible to continue to earn your confidence and your loyalty.

Our very best wishes for many years of safe and fulfilled camping pleasure and memories that will last a lifetime!

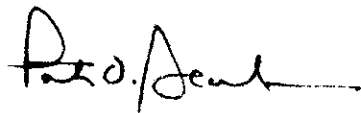

Patrick O. Scanlon
Division General Manager
Folding Trailer Division

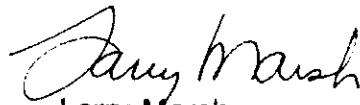

Larry Marsh
Director of Sales and Marketing
Folding Trailer Division

TABLE OF CONTENTS

INTRODUCTION	1	WATER SYSTEMS	17-20
<hr/>		Water Tank	17-18
IMPORTANT CONSUMER INFORMATION	2	Sink Drain	18
<hr/>		12 Volt Electric Demand Water Pump	18
PRE-TRIP PREPARATIONS	3	Water System Versatility	18
<hr/>		City Water Supply	18
TOWING AND TRAILER WEIGHTS	4-5	Use of the Water Tank	18-19
Towing	4	Trouble Shooting the Water System	19
Definitions of Trailer Weights	5	Draining and Winterizing the Water System	20
<hr/>		<hr/>	
SET-UP INSTRUCTIONS	5-14	TRACKING SYSTEM	20-22
Trailer Series/Model Identification	5	Tires	20
Operating Lift System	6	How to Change a Flat	21
Stabilizer Jacks	6-7	Brakes	21
Beds	7-8	Breakaway Switch	21
Tent Enclosure	8	Ball Hitch and Coupler	21-22
Swing-Level Galley	8	Wheel Bearing Lubrication	22
Hinged Galley/Stove Cabinet	8	<hr/>	
Hard Wall	8-9	LIFT SYSTEM	22-23
Bed Bow Support Rod	9	Maintenance	22-23
Dinette	9	Top Adjustment	23
Screen Door	9-10	<hr/>	
Pull-Out Goucho Bed	10	TENT ENCLOSURE	23-25
Front Trunk	10	Sunbrella 302 Fabric	23
Front Trunk Lighting	10	Evolution 3 Fabric	23-24
Pantry Drawers	10	Condensation Preventive Maintenance	24
Mini-Blinds	11	Vinyl Bed Covers	24-25
Shades	11	<hr/>	
Shower	11-12	ROOF MOUNTED ACCESSORIES	25
Shower Curtain Board	11	<hr/>	
Shower Curtain	11	ELECTRICAL	25
Inside Shower	11	<hr/>	
Outside (Hand-Held) Shower	12	CONVERTER	25-26
Dressing Room Curtain	12	12 Volt Vehicular Electrical Circuit	26
Inside Galley Stove	12	110 Volt AC Power Supply	26
Outside Stove	12-14	Wiring Diagram	27-28
<hr/>		<hr/>	
TAKE-DOWN INSTRUCTIONS	14-16	MAINTENANCE	29-30
Crank-Down Stabilizers	15	<hr/>	
Swing-Down Stabilizers	15	WARRANTY	31-32
Power Lift	15	<hr/>	
<hr/>		REPORTING DEFECTS	32
GAS SYSTEM	16-17	<hr/>	
Gas Bottle	16		
Gas Bottle Regulator	16-17		
L.P. Gas Regulator Freeze-Up	17		

INTRODUCTION

This manual contains important information regarding the safe operation and maintenance of your Fleetwood folding trailer. We urge you to read it carefully, understand all aspects of your trailer, and follow the recommendations to obtain the most trouble-free use of your recreational vehicle.

In this manual, statements preceded by the following words are of special significance:

"WARNING" means that there is a high possibility of serious personal injury to yourself and others if the warning is not complied with.

"CAUTION" means that there is the possibility of personal injury to yourself or others.

"IMPORTANT" means that there is a possibility of damage to the trailer if instructions are not followed.

"NOTE" indicates points of particular interest for more efficient and convenient operation.

We recommend that you take particular notice of these items when reading this manual.

NOTE:

The words "shall" or "must" indicate a requirement which is essential to satisfactory and safe product performance.

The words "should" or "may" indicate a recommendation or advice which is not essential and not required but which may be useful or helpful.

Please remember that when service is required, your Fleetwood folding trailer dealer knows your vehicle best. Consult him for any assistance you may require.

NOTE:

Federal law requires you to register the serial numbers of your trailer tires. For your protection, the original equipment tire serial numbers must be recorded on the warranty registration form received with your trailer. Your dealer will supply you with the necessary forms to register any additional tires (spares) you may purchase. Tire registration is not a guarantee or warranty for either the tires or the trailer.

NOTE:

Illustrations in this manual are representative of function and may or may not be specific in their depiction of actual equipment, interior or exterior decor or design, and options as installed on or in your trailer.

NOTE:

This product is designed for recreational use and short-term occupancy only. It is not designed nor intended to be used as permanent housing.

IMPORTANT CONSUMER INFORMATION

Installation and Instructions for Appliances. Operating instructions are provided for each appliance, including air conditioning appliances (other than automotive type).

This recreational vehicle is equipped with listed fuel utilization equipment and an owner's manual which contains the following information:

WARNING:

L.P. gas containers shall not be placed or stored inside the vehicle. L.P. gas containers are equipped with safety devices which relieve excessive pressure by discharging gas to the atmosphere.

WARNING:

IT IS NOT SAFE TO USE COOKING APPLIANCES FOR COMFORT HEATING.

Cooking appliances need fresh air for safe operation. Before operation, open a window.

This warning label has been located in the cooking area to remind you to provide an adequate supply of fresh air for combustion. Unlike homes, the amount of oxygen supply is limited due to the size of the recreational vehicle, and proper ventilation when using the cooking appliance(s) will avoid dangers of asphyxiation. It is especially important that cooking appliances not be used for comfort heating as the danger of asphyxiation is greater when the appliance is used for long periods of time.

A warning label has been located near the L.P. gas container. This label reads:

DO NOT FILL CONTAINER(S) TO MORE THAN 80 PERCENT OF CAPACITY.

Overfilling the L.P. gas container can result in uncontrolled gas flow which can cause fire or explosion. A properly filled container will contain approximately 80 percent of its volume as liquid L.P. gas.

Do not use portable fuel-burning equipment including stoves inside the recreational vehicle. The use of this equipment inside the recreational vehicle may cause fires or asphyxiation.

Do not store L.P. gas containers, gasoline, or other flammable liquids inside the vehicle because a fire or explosion may result.

IF YOU SMELL GAS:

1. Extinguish any open flames, pilot lights, and all smoking materials.
2. Do not touch electrical wires.
3. Shut off the gas supply at the tank valve(s) or gas supply connection.
4. Open doors and other ventilating openings.
5. Leave the area until odor clears.
6. Have the gas system checked and leakage source corrected before using again.

L.P. gas regulators must always be installed with the diaphragm vent facing downward. Regulators that are not in compartments have been equipped with a protective cover. Make sure that regulator vent faces downward and that cover is kept in place to minimize vent blockage which could result in excessive gas pressure causing fire or explosion.

PRE-TRIP PREPARATIONS

Before you seek out those favorite recreational campsites with your new Fleetwood folding trailer, we suggest you first make these pre-trip preparations.

Read the information in this booklet very carefully. Please note that the text for the set-up and take-down instructions does not differentiate between models. When the text does not apply to your model, continue on to the next applicable step. Set up and take down the trailer per the instructions several times to familiarize yourself completely with the procedure.

Establish a tool kit for your trailer's maintenance needs and stow it in the trunk of your tow vehicle. The following items should be included:

1. Standard slot screwdriver
2. Standard phillips screwdriver
3. Hydraulic or scissor jack (1 1/2 ton)
4. 13/16" lug wrench
5. Stabilizer jack handle (furnished)
6. Crankshaft handle (furnished)
7. Four wheel chocks

Final preparations should include the proper loading and physical check of the trailer before the trip.

The trailer should be loaded with these basic rules in mind:

1. Keep your trailer as light as possible. Reducing weight will increase gas mileage.
2. Distribute the weight as evenly as possible.
3. **Be certain that a minimum of 10% of the overall trailer weight is on the ball hitch of the tow vehicle. Less than 10% will result in a negative tongue weight causing whipping or swaying while towing.**
4. Water tanks do not need filling unless primitive camping is planned; fill water tanks at campground to reduce towing weight.

Make your first trip close to home if possible. This will serve as a preparatory trip to see that everything works and what other items you will need to take.

A physical check should also be made per this checklist. Be certain that:

1. Tires are inflated to the recommended pressure as indicated on the tire sidewall.

NOTE:

The three main causes for early tire wear and/or premature tire failure are:

- a. Under inflation
- b. Over loading (cargo)
- c. Improper towing (see towing section)

Due to the relatively small tire sizes used on folding trailers always check the tire air pressure prior to each camping trip. Temperature changes can result in loss of tire air pressure. See Specification Chart located inside trailer for cargo capacities.

2. Wheel lug nuts/bolts are properly torqued: 8" wheels, 70-80 lbs; 10"/12" wheels, 80-90 lbs. Check torque before first trip. Retorque after first 25 miles. Retorque after first 75 miles. Retorque periodically thereafter and before each trip.
3. The tongue coupler is securely fastened to the ball hitch with safety pin in place.
4. The safety chains are attached (chains must crisscross).
5. The electrical pigtail is connected.
6. All lights on the trailer are functioning properly.
7. The L.P. gas bottle valve is closed.
8. The cooler and other items are securely held in place.

We hope you read and follow these instructions and helpful hints very closely. If you do, you will receive the maximum benefit from your Fleetwood folding trailer.

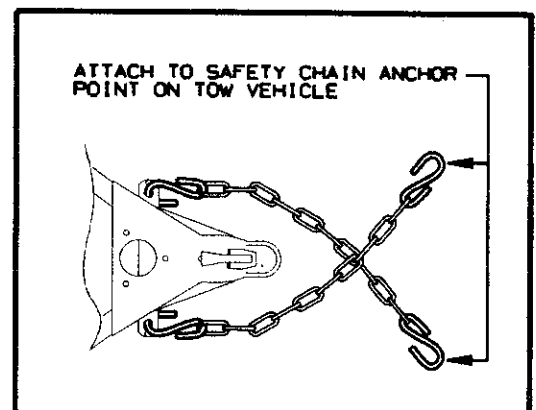

TOWING AND TRAILER WEIGHTS

TOWING

It's of utmost importance to keep the trailer as level as possible when hooked to the tow vehicle's hitch. Towing a trailer with the tongue inclined will cause premature tire wear. This is also found to be true if the tongue area is angled downward.

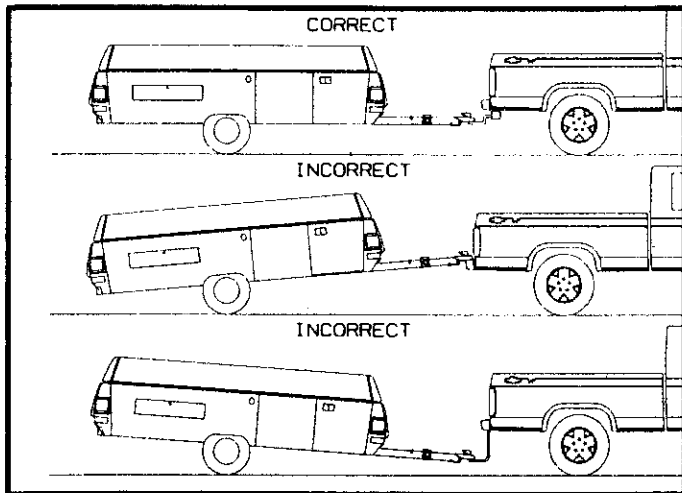

Even if you've towed before, you'll want to get the feel of maneuvering any new outfit, so practice starts, stops, parking, braking, and turning. When driving around town, always check the traffic clearance before pulling out from the curb or shoulder into the main traffic flow.

For turns, pull past your turn or intersection sufficiently before turning so as not to run into the curb or obstructions. The longer your trailer, the wider you must swing for clearance. Most new owners are surprised at how well Fleetwood folding trailers track and how little additional maneuvering space is required, but don't let this cause you to forget it's behind you.

During parking or backing, remember that the rear of the folding trailer moves opposite to the rear of the towing vehicle. Start by simply placing your hand on the bottom of the steering wheel, then moving your hand left (wheel turning right) will move the trailer to the left and vice versa.

On the road, maintain a safe driving distance from other vehicles. A safe driving distance is the total length of your towing vehicle and folding trailer combined for each ten miles per hour of speed.

When approaching a downhill grade, downshift, letting the engine compression act as a brake. Should you need added braking, apply your brakes as required.

When approaching an uphill grade, the answer is the same - downshift. This keeps the engine from lugging down which may overheat from laboring in a higher gear.

Your towing equipment, its adjustments and how you load the trailer will have a great effect on trailer towing stability and handling.

NOTE:

Use a tow vehicle that is large enough for your trailer and has the needed power and appropriate towing equipment package.

Hitching up your trailer will become routine with experience. Make it a habit to examine all hitch components before hitching the trailer. Check for cracked or bent parts, cracked welds, and deformed or stripped bolts. Be sure the hitch ball is tight and well lubricated. Inspect the safety chains. If you find defects in any hitch component, correct it before towing the trailer.

To determine specific weights of your Fleetwood folding trailer, follow these procedures using a platform scale such as those used by trucking companies or highway weigh scales:

GROSS VEHICLE WEIGHT: Pull folding trailer on the scale, lower the tongue jack, and move vehicle off of the scale. Both the trailer axle and tongue jack must be on the scale. The measured weight of the loaded trailer must not exceed the Gross Vehicle Weight Rating (GVWR) of the trailer. Cargo or equipment must be removed until the GVWR is not exceeded.

GROSS AXLE WEIGHT: Position the trailer so that only the axle rests on the scale and the tongue jack is off the scale.

TONGUE WEIGHT: Position the trailer so that only the tongue jack rests on the scale. The tongue weight must be 10% of the Gross Vehicle Weight for best towing results.

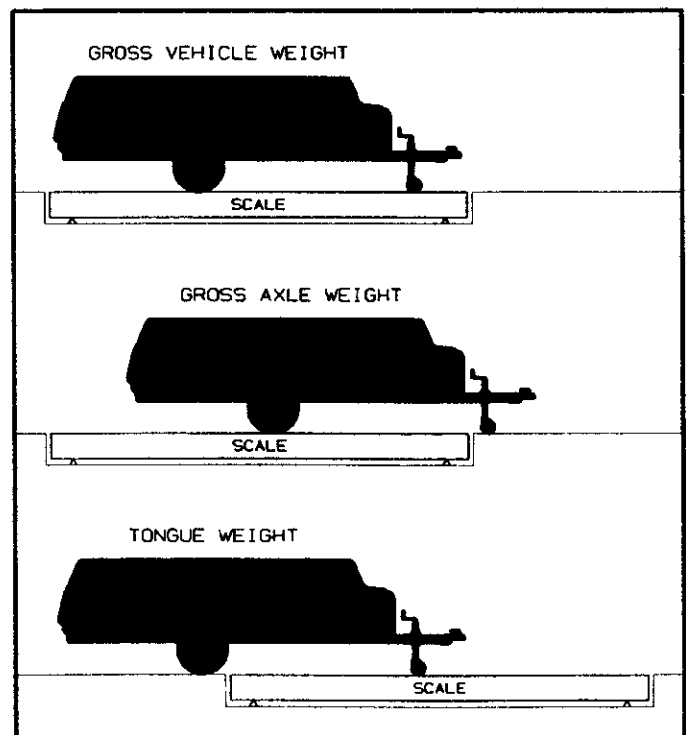

DEFINITIONS OF TRAILER WEIGHTS

GROSS AXLE WEIGHT RATING (GAWR) - Weight carrying capacity of the axle while the trailer is in tow.

GROSS VEHICLE WEIGHT RATING (GVWR) - The maximum loaded weight the trailer can safely accommodate while in tow.

CARGO WEIGHT - The weight of all additional goods placed in or on the camping trailer and trailer hitch while in tow.

NOTE:

Cargo weight will include all accessories and fluid (LP gas, water).

WARNING:

Do not exceed the rated load of the tow vehicle, the trailer, or the rated load of any axle.

WARNING:

Exceeding the GAWR or GVWR of your tow vehicle or trailer can cause undesirable handling characteristics and may create a safety hazard.

To calculate the cargo weight with full LP gas bottle and a full water tank, these weights must be deducted from dry cargo weight.

EXAMPLE:

LP gas in one bottle	20 lbs.
10 gallons water *	<u>83 lbs.</u>
Total fluid weight	103 lbs.

Cargo capacity weight	480 lbs.
Total fluid weight	- <u>103 lbs.</u>
Available cargo weight for transit	377 lbs.

* Water weighs 8.345 pounds per gallon.

IMPORTANT:

Optional accessories added to the trailer must also be deducted from available cargo weight.

Width - All 6'8"

Interior - All 6'5" except Four Season Series which are 7'1"

Coupler size - All use 2" (maximum vertical load 350 pounds, Class 2)

Electrical - 110 VAC, 30 amp

Trailer weights listed on Specification Sheet (located in the trailer literature package) are subject to 5% variation due to raw materials.

Fleetwood Folding Trailers, Inc. reserves the right to change specifications, design, or material of its products at any time without notice or incurring any obligation to incorporate such changes in any product previously manufactured.

SET-UP INSTRUCTIONS

This owner's manual contains information for the Four Season, Americana, Pioneer, and Destiny series trailers. Below listed are the model names of each series of trailers:

FOUR SEASON SERIES

Cape Cod
Yosemite
Hatteras

AMERICANA SERIES

Sequoia
Williamsburg

PIONEER SERIES

Chesapeake
Chesapeake CP
Avalon
Columbia
Arcadia

DESTINY SERIES

Cedar Roanoke
Cedar XL Rio Grande
Cedar MT Stony Creek
Royale

IMPORTANT:

Operations for items such as the lifting system, stabilizers and galley may vary between the different series trailers. The operating instructions for all series of trailers are outlined in this manual. When reading this manual, follow the operating instructions that pertain to your particular model trailer.

Prior to the initial camping trip, familiarize yourself completely with the operation, care and construction of your new Fleetwood folding trailer. We suggest that you set up your Fleetwood folding trailer slowly and per the set-up instructions to prevent unintentional damage to the equipment.

Select a level campsite, preferably not on soft or sandy terrain. Pull or back the folding trailer to desired position for campsite. Disconnect electrical pigtail and safety chain, and release the coupler release handle. Pull the lock pin (located on the tongue jack) and let the tongue jack swing down into position. Allow the lock pin to lock the tongue jack in place in the top left hole in the brackets.

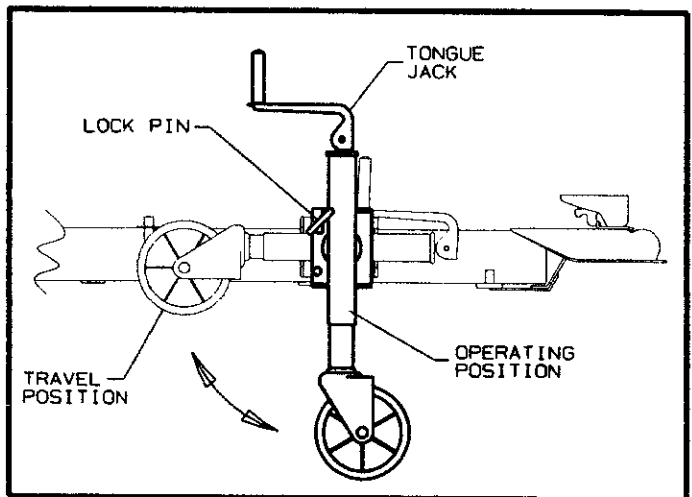

TONGUE JACK

CAUTION:

Failure to engage the tongue jack lock pin could result in the trailer tongue falling resulting in injury to yourself or others.

Pull the handle of the tongue jack up and rotate the handle in a clockwise motion to lift the trailer tongue up and off the ball hitch. To prevent interference during the set up of the trailer, drive the vehicle away from the trailer or move the trailer to the desired location for the campsite. Adjust the tongue jack height so that the trailer is level horizontally. Unlatch the four "top" latches.

NOTE:

On **Four Season model trailers**, the two curbside top latches can be utilized as an aid in lifting the top to allow clearance between the top and the access door prior to raising the top assembly for access to the power lift controls.

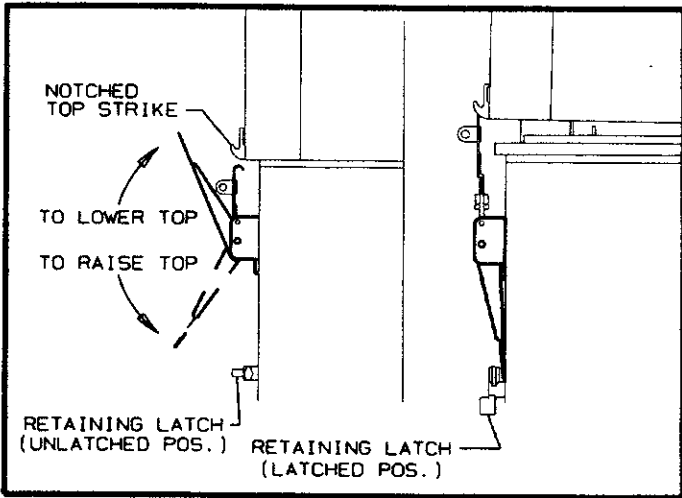

TOP LATCH LIFT

On **Americana, Pioneer, and Four Season models**, insert the key into the access door lock and turn clockwise. The push-button and handle will pop out. Rotate the handle clockwise to open the access door. Pull out and down on the access door to provide an entrance.

IMPORTANT:

Before lowering the access door, insure that the area directly beneath the access door is free from obstacles to prevent damage to the exterior finish of the access door.

OPERATING LIFT SYSTEM

AMERICANA SERIES/YOSEMITE AND HATTERAS MODELS

NOTE:

On **Americana models**, the power lift controls are located on the front body panel and the gravity release cable is located on the gas bottle brackets. On **Yosemite/Hatteras models**, all power lift controls are located on the curbside cabinet.

Turn the release valve clockwise to the fully closed position. Ensure the gravity release cable is pushed fully inward.

Lift the toggle switch and hold in position to raise the top assembly. Allow the top assembly to fully extend or until tent fabric becomes taut. Release the toggle switch.

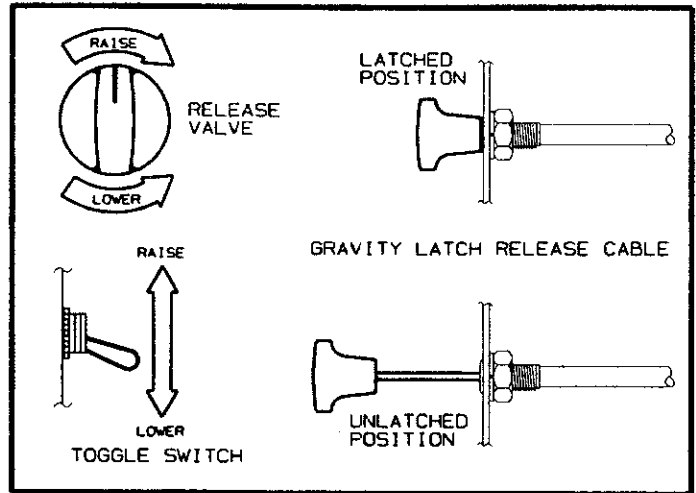

POWER LIFT CONTROLS

IMPORTANT:

Ensure release valve is completely closed by turning clockwise until snug before utilizing the power lift. A partially open valve will not allow the top assembly to raise.

IMPORTANT:

The power lift must be supplied with 12 volt DC from an auxiliary tongue mounted battery. The power lift is not powered by the trailers converter.

PIONEER/DESTINY SERIES AND CAPE COD MODELS

Attach crank handle onto the crank shaft. Rotate the crank handle in a clockwise motion to raise the top until it is fully extended or the tent fabric becomes reasonably taut, whichever comes first.

NOTE:

On **Destiny models** - Once the top is raised, the access door can be opened and latched into the open position utilizing the retaining latch on the body panel.

STABILIZER JACKS

AMERICANA SERIES/YOSEMITE AND HATTERAS MODELS

Insert crank handle onto stabilizer shaft and rotate crank handle clockwise to extend jack to downward position. Repeat for remaining stabilizers and return crank handle to storage location.

IMPORTANT:

The threaded shaft of the crank-down stabilizer jacks should be lubricated (with white lithium grease or equivalent) at the beginning and end of each camping season to deter corrosion due to weather related elements.

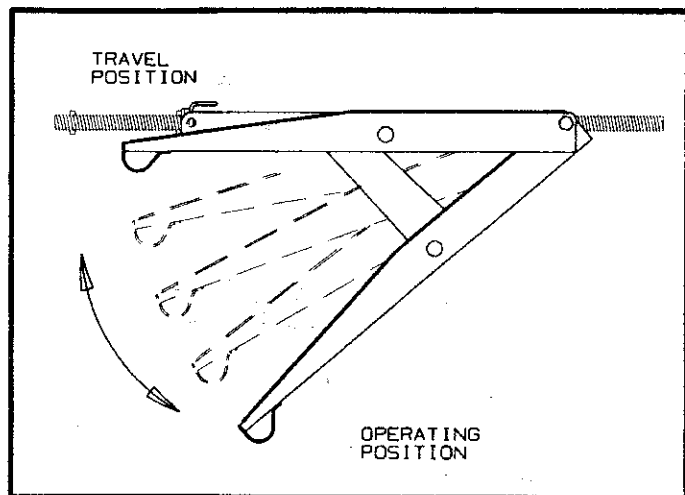

CRANK-DOWN STABILIZER

PIONEER/DESTINY SERIES AND CAPE COD MODELS

To release the stabilizer jacks from the locked travel position, reach under the corner of the trailer, firmly grasp the jack and push it toward the center of the trailer (approximately 1/2"), and swing down to lock the jack in the lowered position. By pushing down on the quick release lever, the inner leg can be extended to the ground. Insert the stabilizer handle through the front hole and allow handle to pass completely through the rear hole of the stabilizer. Apply downward pressure to extend the inner legs of the stabilizer jacks to stabilize the trailer.

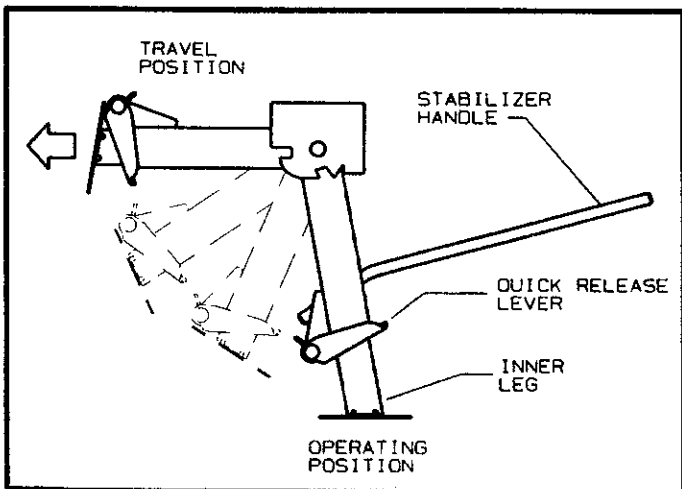

SWING-DOWN STABILIZER

IMPORTANT:

Ensure stabilizer handle is extended through the rear hole of the stabilizer or inadvertent damage can occur to the inner stabilizer leg.

Repeat procedure for remaining stabilizers.

NOTE:

Not all **Destiny** models are equipped with 4 stabilizers. Certain models utilize the trailer tongue jack as a stabilizing support.

CAUTION:

Do not lower the stabilizer jacks prior to raising the trailer top as this can place an undue stress on the trailer frame and lift system resulting in premature wear. Do not use the stabilizer jacks to take the weight of the trailer off of the tires. The jacks are intended **ONLY TO "STABILIZE."**

WARNING:

Do not lie under trailer when putting stabilizers down or up. Should the trailer fall, serious bodily injury could result.

IMPORTANT:

Lubricating of the swing-down stabilizer jacks is not recommended, due to the metal surface contact needed for proper operation of the inner stabilizer leg.

Because of certain terrain conditions, it may be advisable to locate flat blocks of wood or flat rocks under the base plates of the stabilizer jacks.

BEDS

Standing right of center at the tongue end of the trailer, place hands on the bed frame and pull outward until the bed stops.

IMPORTANT:

This movement must be done slowly and evenly to prevent inadvertent jamming or wedging of the bed on the sliding tracks.

IMPORTANT:

DO NOT put any weight on the beds while they are extended without first attaching the bed supports as damage to the bed rails or bed frames may result. Any damage to the bed rails or bed frames, resulting from weight being applied to the bed area without the bed supports in position, will not be considered a warranty item.

Kneel down beneath the side of the fully extended bed. Pull down and swivel the bed support tubes from their travel positions. Lift the bed slightly while placing the free end of the bed support tube over the support peg. Perform same procedure for the rear bed. The **Stony Creek** model trailer rear bed legs utilize a spring pin adjustment lock. Ensure the spring pin is fully engaged prior to attaching the bed leg to the bed support pin.

IMPORTANT:

Insure bed support post is fully engaged on the peg, otherwise any weight placed on the bed will cause damage to the bed rail or bed frame.

Bed supports are designed to swivel into travel or setup position; do not force the bed supports when setting up or taking down.

TENT ENCLOSURE

With both beds fully extended and supported, grasp the bottom edge of either the front or rear tent enclosure and gently pull until the tent fabric is pulled out toward the end of the beds. Standing at either side of the bed, reach in underneath the tent fabric and grasp the side of the canvas bow and rotate toward the end of the bed. Pull the tent at the bottom over the bed edge and attach the exposed stretch cords to the nearest hooks on the underside of the bed. Repeat for other bed end. Where applicable slide the stiffened tent fabric sections under the bed corners between the bed bottom and body rail top.

NOTE:

Americana and Pioneer models have storage pouches designed into the lower section of the side tent enclosure panels.

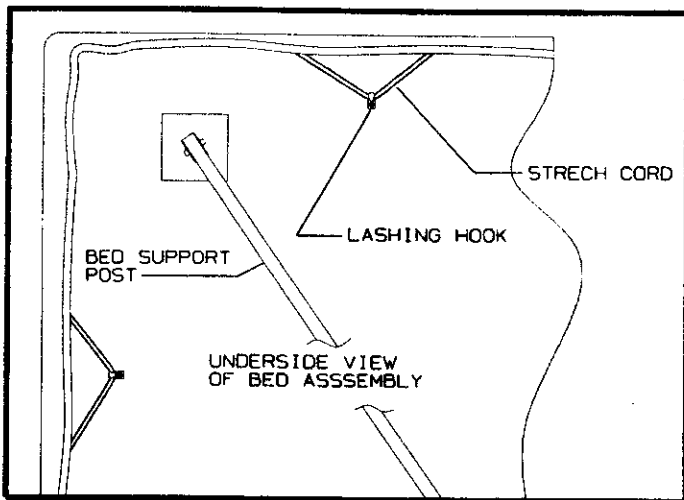

TENT BED HOOKS

CAUTION:

Do **not** store sharp objects within the storage pouches or irreversible damage could occur to the tenting material.

SWING-LEVEL GALLEY

AMERICANA/PIONEER/FOUR SEASON MODELS

Grasp the center of the tubular bar of the swing-level galley and raise until the bottom of the upper galley rests securely on the top of the lower galley compartment.

CAUTION:

Be certain to grasp the swing-level galley tubular bar in the position indicated by the decal (center). Failure to do so could lead to inadvertent pinching of the hand as galley rotates.

CAUTION:

Slide the safety ties attached to the bottom of the drapes into the track behind galley. These ties eliminate the possibility of the drapes coming in contact with the stove.

HINGED GALLEY/STOVE CABINET

DESTINY MODELS

Hinged Upper Galley

Grasp the towel rack of the hinged upper galley assembly. Lift up and rotate towards the outside of the trailer.

Stove Cabinet (Roanoke model only)

Move stove cabinet from floor storage location and position into cut-out on hutch cabinet top. Locate gas line and route into stove cabinet through opening in hutch cabinet top.

With the gas valve in the "OFF" position engage the gas disconnect to the stove assembly and open the gas valve.

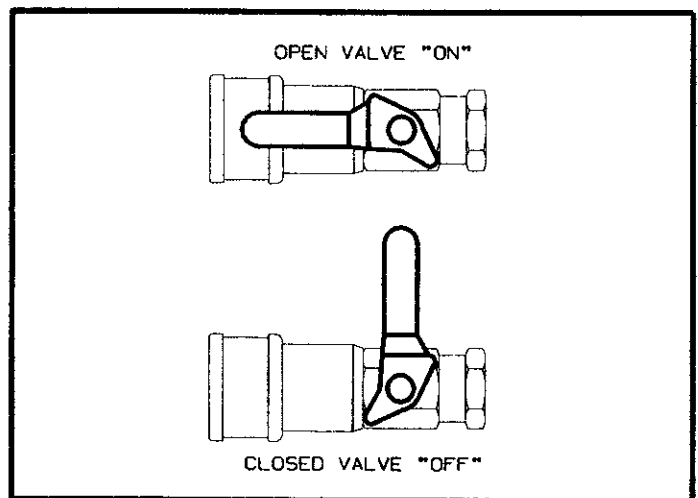

GAS QUICK DISCONNECTS

HARD WALL

FOUR SEASON MODELS

With both front and rear beds fully extended and set-up, enter the trailer. Raise the door side hard wall into full upright position against the side of the top assembly. While holding the wall into position, rotate the center retaining knob 90 degrees to secure the wall section into place. Once center retainer is locked into position, locate and lock the remaining retainers into position. Repeat procedure for the opposite or off-door side wall.

NOTE:

Ensure all retaining latches have made contact with the retaining bracket and are securely locked.

IMPORTANT:

When raising the hard walls, start at the center or middle retainer first to avoid binding or misalignment of remaining lock tabs.

BED BOW SUPPORT ROD

To completely support the tent enclosure over the bed (front and rear), attach the bed bow support rod by inserting the straight end into the bed bow. Insert the opposite end of the bed bow support rod into the metal roof retainer. Adjust bed bow support rod as necessary to make the tent enclosure over the bed taut. This is done by pressing the release button on the pole and extending the rod to the next adjustable hole.

NOTE:

These may be stored in a preadjusted state under each mattress.

DINETTE

Lift the backrest off the dinette table. Lift the table and place face-down on mattress for later set-up. Slide the seat cushion inboard. Set the backrest in place. Slide the seat cushion in place against the backrest, making sure that the plastic stops are wedged firmly against the interior of the seat frame.

NOTE:

To lift dinette seat, be certain to push the seat cushion firmly toward the backrest before lifting in order to prevent inadvertent damage to the plastic stops. The **Avalon model** trailer has additional backrest support boards that must be raised to the upright position prior to placing backrest in position.

NOTE:

Where applicable a flip-up seat retainer is provided to hold the cushions upright to permit seat storage access.

Extend the table legs completely so that both leg supports lock into position. Set table upright and check to insure it is stable. The **Stony Creek model** trailer has an additional drop leaf table section. To utilize the drop leaf, lift the leaf section and slide the retainer outward to hold in the up position.

CAUTION:

The table top could be damaged by exposure to rain or extended periods of sunlight.

SCREEN DOOR

Unfasten the two screen door web retaining straps. This will allow the screen door to hang by its glide cables.

Standing at the door opening, pull down on the spring-loaded pin clip retaining the door frame and swivel clear of the engagement hole. Standing at the door threshold, reach up and grasp the bottom of the screen door with both hands. Raise and push the door toward the far side of the trailer to release it from its retaining brackets. Hold screen door up from the floor and move it toward the door opening.

From outside the trailer, grasp the door frame with both hands, one on either side, lower screen door into door threshold at base of doorway. Unlock screen door latch and step inside.

AMERICANA/PIONEER/FOUR SEASON MODELS

Holding the door against the top assembly, lock into place with the two screen door sash locks.

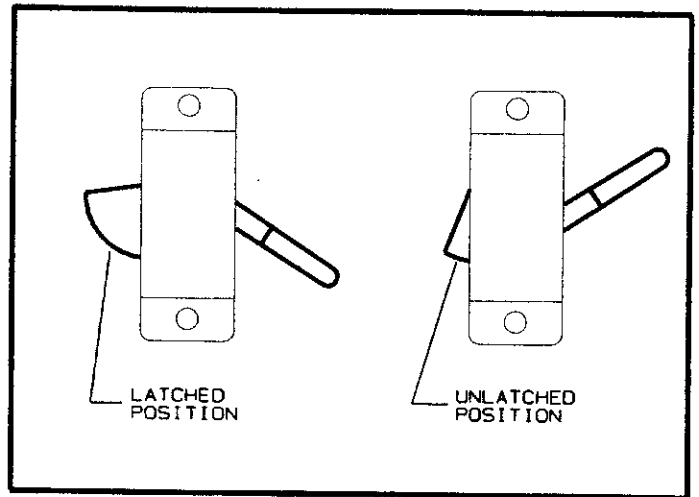

SASH LOCKS

DESTINY MODELS

Grasp the top extrusion with one hand. Using your free hand, guide the screen door lock tabs into the preslotted top plate. Turn the lock tabs to secure the screen door to the top assembly. Attach the tenting material onto the mating velcro on the screen door top plate.

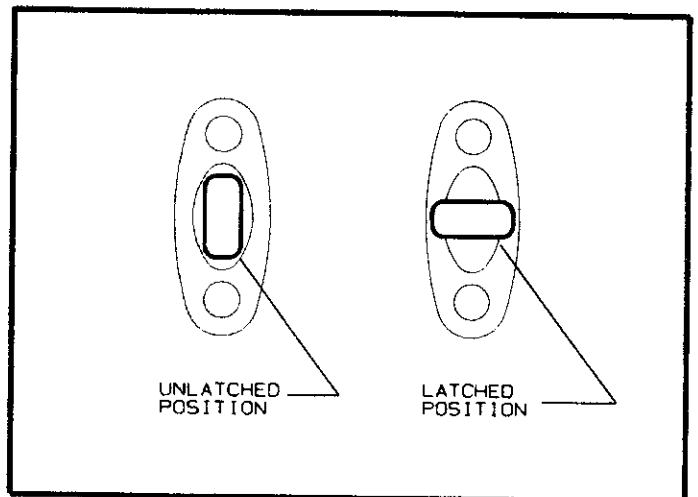

LOCK TABS

On **Americana, Pioneer, and Destiny** models, start at the base of the tent material, press the tent weather seal on either side of the door frame into the weather seal groove on the door frame. Fasten tent material patches to the door frame and body rail with the mating velcro. On **Four Season** models, step outside trailer, grasp the vinyl flap with both hands. Starting at the base of the material, press the tent weather seal on either side of the door frame onto the mating velcro on the hard wall. Once both hard walls have been locked into position and the screen door is set up, from the outside of the trailer, attach snaps from bed end tent sections to mating snaps located on trailer side hard walls. Ensure all bed end velcro patches have been attached to the mating velcro on the body rails and hard walls.

NOTE:

On very tight tents, set-up is much easier if the screen door weather seals are installed prior to attaching the tent at bedends. Rest each bed tent on top of the beds, install the weather seals, and then pull the tent over the bed edges.

NOTE:

The screen door has two removable window panes which can be removed to allow a full length screen for additional ventilation.

PULL-OUT GOUCHO BED

STONY CREEK/AVALON MODELS

Remove the backrest and seat cushions from goucho and set aside. Standing at the center of the goucho, grasp the seat frame and gently pull outward towards the center of the trailer until the stop buttons rest against the stop bracket. Lay the seat cushions outward towards the body rails. Lay the backrest cushions on top of the extended wood platform.

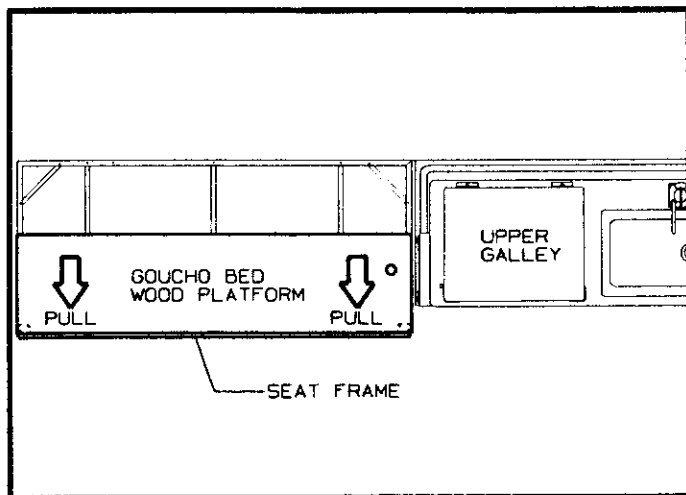

GOUCHO BED

FRONT TRUNK

AVALON/RIO GRANDE/CEDAR XL MODELS

To access the trunk area, with the trailer in the **closed position**; unlock the three front top latches. Lift the trunk storage lid. Remove prop rod from the retaining brackets located along the front rail. Insert the free end of prop rod into the retainer on the trunk lid to hold in the open position. **Side access** to the trunk area can be achieved by opening the side access doors on either side of the trailer. Insert the key and turn clockwise to open. The front trunk storage area can be accessed from inside the trailer with the trailer in the **open position** through the front interior paneling. Slide the interior access panel to the left to gain access.

FRONT TRUNK LIGHTING

For models equipped with front trunk storage, interior lighting is provided to allow visibility in low lighting situations such as evening arrival at campgrounds.

With the trailer in **closed** position and the tow vehicle connected to the trailer:

1. The exterior marker or running lights **must** be turned on to supply 12 VDC to the interior trunk light.
2. Lifting the trunk lid will automatically turn on the interior trunk light.

With the trailer in the **open** position and the tow vehicle disconnected from the trailer:

1. 12 VDC power must be supplied by either having the converter plugged into 110 VAC and the converter selector switch in the "convert" position or by an auxiliary battery and the converter selector switch turned to the "batt" position.
2. Locate the rocker switch on the front lower galley section near the storage sliding access panel. Turn switch to the "on" position to activate interior storage light.

PANTRY DRAWERS

AVALON/RIO GRANDE MODELS

Unlock barrel bolt, located on the top of the pantry drawer, and pull the pantry drawer out towards the center of the trailer.

NOTE:

Ensure sliding access panel is closed and pantry drawers are in the locked position prior to closing the trailer in the travel position.

MINI-BLINDS

AMERICANA MODELS

To Release Mini-Blind: Unzip the storage bag to expose mini blind, pull cord and adjusting rod.

To Lower Mini-Blind: Pull straight down on the cord slightly, and move it approximately 45 degrees to either the left or right and lower the blind. Stop the blind in mid-travel by moving it back to the straight down position.

To Raise Mini-Blind: Pull straight down on cord and release at desired height. It is not necessary to pull the cord to one side or the other to secure blind.

To Adjust Mini-Blind: Turn the adjusting rod either direction.

To Install Valance: Attach velcro tabs, sewn onto the back of valance, to the velcro strip applied to the front of the mini-blind storage bag.

SHADES

YOSEMITE/HATTERAS MODELS

To Lower Shade: Pull straight down on the shade slowly to desired height.

To Raise Shade: Gently lift shade upward. The shade will refold as upward pressure is applied.

NOTE:

Raise shades when closing trailer to travel position. This will prevent any damage to the pleats on the shades.

To Install Valance: Attach velcro, sewn onto back of valance, to the velcro strip applied to the shade.

SHOWER

ARCADIA/WILLIAMSBURG/HATTERAS MODELS

SHOWER CURTAIN BOARD

Remove the shower curtain board from the storage location on the tub by grasping the edge of the board and lifting.

For Williamsburg and Arcadia models, insert side edge into retaining bracket located in top assembly. Press the shower curtain board flush against the top assembly. While holding in position, rotate the two (2) twisting fasteners 90 degrees in order to retain the shower curtain board in the top location.

For Hatteras models, insert the shower rod onto the retaining brackets located in the top assembly. Lift the free end of the shower curtain board towards the top and attach the two (2) web straps to the snaps located on the shower curtain board.

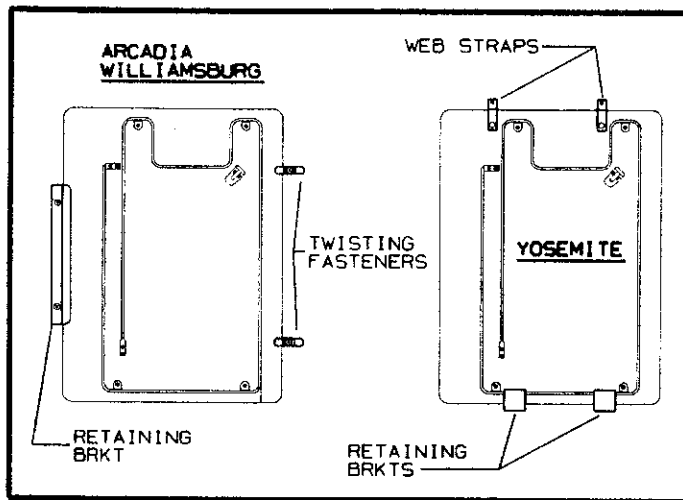

SHOWER CURTAIN BOARD

CAUTION:

Hold the shower curtain board firmly when placing in the top usage position. Accidental slippage may result in damage to the shower curtain board, tub, and/or personal injury.

SHOWER CURTAIN

Install the shower curtain hooks/carriers to the curtain track and attach the shower curtain.

NOTE:

When the shower is not in use, the curtain can be left attached and conveniently stored by lowering the shower curtain board to the travel position; however, the curtain should be dry before storing to prevent mildew.

INSIDE SHOWER

Connect a garden hose (not supplied) to the tub drain located on the lower portion of the exterior body panel and route to a park-supplied drainage receptacle or a suitable waste container. Connect the shower head hose to the tub fitting and hand tighten. Adjust the shower curtain to insure that the total area around the tub is sealed and the curtain bottom is inside the tub. Open hot and cold faucets 1/4 turn and adjust to temperature and pressure desired.

NOTE:

When your trailer is being stored for extended periods of time, it is recommended that the shower curtains be removed from the unit, folded, and stored indoors under fairly constant temperatures. Extremes of temperatures could have an adverse effect on the plastic material.

OUTSIDE (HAND HELD) SHOWER (Sequoia model only)

Open shower access door located on left side body panel by inserting key and turning clockwise. Swing shower head out away from panel. Slowly open faucet control knobs. Turn the control lever on top of the shower head to allow water to flow.

NOTE:

Either city water supply or the electric pump system must be in operation to allow water to flow to the outside shower.

Lift the shower head off of the retaining bracket to allow the shower to be utilized away from the trailer. Gently pull the shower head and hose to desired length. (Shower hose will extend approximately 5 ft maximum.)

WARNING:

The hot water drawn at the shower is directly out of the water heater. The temperature of the water could be as high as 150°. Scalding could occur if the hot water is not diluted. DO NOT expose the body directly to the undiluted hot water.

DRESSING ROOM CURTAIN (where applicable)

The dressing room curtain can be installed in the tracks located in the top assembly by following this simple procedure. Slide all carriers with the hooks onto the I-beam, making sure that all hooks face the same direction. Assemble the curtain stop to I-beam by sliding stops onto the ends of I-beam, locate approximately 1/4" from each end of I-beam, and tighten thumb screw tight with your hand.

IMPORTANT:

If pliers are used, care should be taken not to over-tighten.

Assemble curtain to track by placing carrier hooks on track through small eyelets in curtain. Hooks may be squeezed together with thumb and forefinger after the curtain is hung to secure it to the hook.

INSIDE GALLEY STOVE

AMERICANA/PIONEER/FOUR SEASON MODELS

Unfasten the catch securing the stove cover. Raise the stove cover into position. Rotate the splash guard toward side of stove and fasten to side of cook top with twist latch. Check to insure all burners on the stove unit are turned off. Open the valve on the LP gas bottle all the way by rotating handle in a counterclockwise direction. Turn on one LP burner on the stove unit and hold a lighted match near the LP burner.

NOTE:

Initially, it will take 20-40 seconds for the gas to flow from the bottle to the burner after which the LP burner will ignite.

DESTINY MODELS

Unfasten the catch securing the stove cover. Raise the stove cover into position. Rotate the splash guard toward the outside of the stove and fasten to the side of the cooktop.

WARNING:

Always ensure the stove retaining pin is engaged when utilizing the stove in the inside location.

NOTE:

Retaining pin is located on the bottom of the stove assembly and can be accessed through the upper galley door.

Check to insure all burners on the stove unit are turned off. Open the valve on the LP gas bottle all the way by rotating the handle in a counterclockwise direction. Turn gas shut-off lever, located on gas quick disconnect, to the "ON" position.

WARNING:

When trailer has been over rough terrain, test gas piping and appliances with soapy water for leakage. DO NOT test with a lighted match. DO NOT tamper with the gas bottle regulator; it is factory adjusted. Failure to adhere to this warning could lead to an undetected gas leak resulting in fire and/or explosion.

CAUTION:

Do not check copper and brass plumbing lines and fittings for leaks using ammoniated or chlorinated household type detergents. These can cause cracks to form on the line and brass fittings.

IMPORTANT:

Do not place hot cooking utensils on cabinet tops or table top. Damage to surface could occur.

Turn on one LP burner on the stove unit and hold a lighted match near the LP burner.

NOTE:

Initially, it will take 20-40 seconds for the gas to flow from the bottle to the burner after which the LP burner will ignite.

OUTSIDE STOVE

AMERICANA MODELS

Using the access door key unlock the stove storage compartment door. Lift front locks, grasp the stove shelf, and slide the entire unit out until it hits the retaining stops. Be certain the two locks, now at the rear, have re-engaged in the retaining slots. Attach gas line from stove to connection located at bottom flange of curbside rear panel.

CAUTION:

This stove connection should NOT be attached directly to any other unregulated L.P. gas source.

Open stove cover and secure splash guards.

The outside stove is now ready for use.

Follow instructions in reverse order to store the stove.

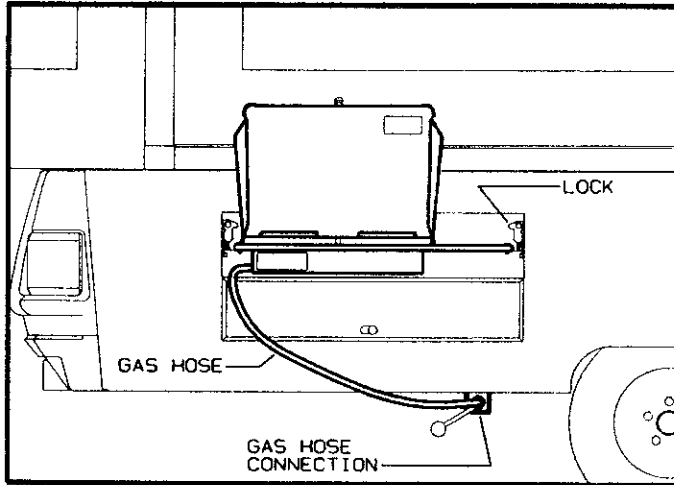

AMERICANA OUTSIDE STOVE

PIONEER/FOUR SEASON MODELS

Remove stove from storage location. Swing support leg into position away from the stove bottom. Using both hands place stove retaining bar onto mounting brackets located on the curbside body rail and lower stove unit until support leg rests against body panel.

IMPORTANT:

Ensure retaining bar is fully engaged onto mounting brackets.

On Pioneer models, unsnap the retaining strap on the counter top extension and unfold into position.

On Yosemite/Hatteras models, gently pull outward on the counter top extension support rod until fully extended. Place counter top extension onto support rod with retaining clips. Lower counter top extension onto support rod. Slide counter top towards trailer to engage rear retaining bracket onto support rod.

NOTE:

The counter top extension is designed for cooking utensils and other lightweight items. Heavy items should not be placed on this counter top or damage could result.

Attach gas line from stove to connection located at the bottom flange of curbside rear panel.

CAUTION:

This stove connection should **NOT** be attached directly to any other unregulated L.P. gas source.

Open stove cover and secure the splash guards. The outside stove is now ready for use.

CAUTION:

Turn on LP gas and check for leaks with a soapy water solution. Never check with an open flame as fire or explosion will occur.

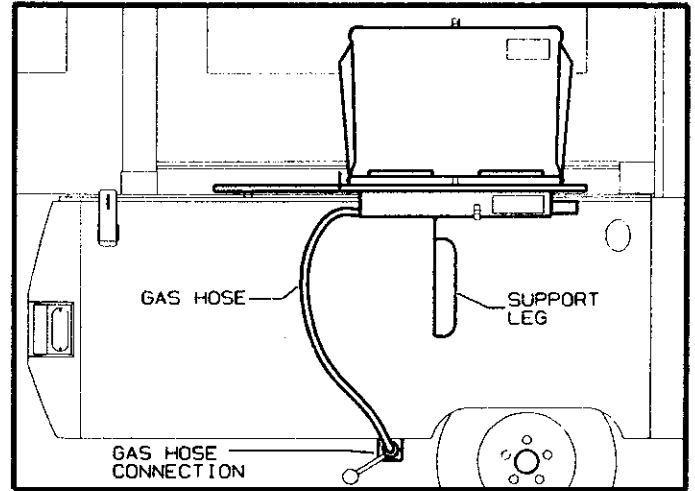

PIONEER/FOUR SEASON OUTSIDE STOVE

CAUTION:

Do not check copper and brass plumbing lines and fittings for leaks using ammoniated or chlorinated household type detergents. These can cause cracks to form on the line and brass fittings.

Follow instructions in reverse order to store stove.

DESTINY MODELS

The following steps should be followed to remove the stove from the inside location in order to utilize the outside location.

Disconnect the gas supply line by first turning the gas shut-off valve to the "OFF" position.

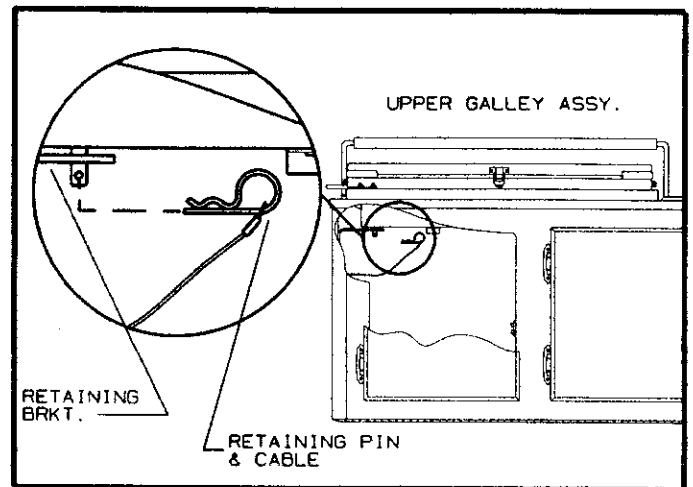

RETAINING PIN

Pull the retaining pin out of shaft (located on the underside of the stove) to release stove from retaining bracket.

Grasp the towel bar and raise the stove module until the bottom of the stove box clears the galley top and slide approximately 6".

WARNING:

Care should be used when disconnecting gas. Never disconnect the stove valve while smoking or with open flame nearby. A small amount of excess gas will be released from the stove module at the time of disconnection.

Carry the stove module outside the trailer. Holding the stove module with both hands, engage the stove hangers onto the retaining brackets located on the curbside body rail. Locate the stove support rod and remove from storage location. Position the stove support rod onto the two retaining loops located on the bottom front of the stove module. Tilt the stove slightly upward and engage the bottom portion of the support rod onto the lower retaining bracket located on the lower section of access door or on the lower frame channel depending on the model. Engage the stove gas line onto the gas quick disconnect located at the bottom flange of curbside panel.

NOTE:

The outside quick disconnect does not utilize a shut-off lever.

Open the stove cover and secure the splash guards on both sides of the stove cooktop. The stove is now ready for use.

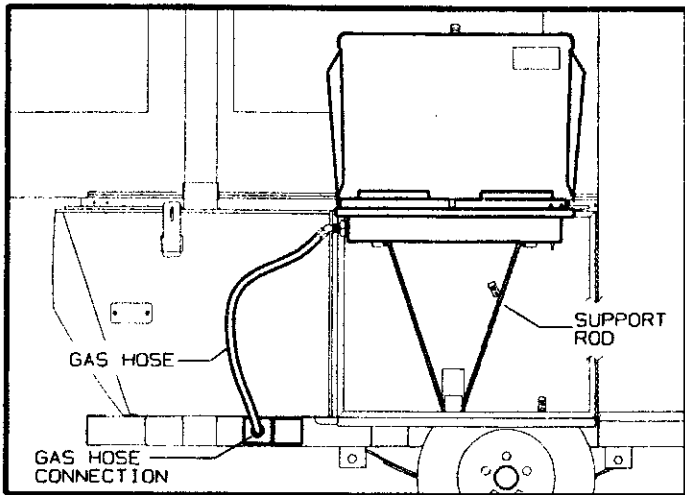

DESTINY OUTSIDE STOVE

Follow instructions in reverse order to move stove module back to the inside galley position.

NOTE:

In order to obtain full counter space when the stove is being used in the outside position, a specially designed cutting board can be placed into the counter top cut-out.

TAKE-DOWN INSTRUCTIONS

Turn circuit breaker and converter switch to the "OFF" position. Unplug the power cord and store.

Disconnect the city water hook-up and attach the protective cap onto the external city water connector. Close and lock utility port door on Americana models.

Close the valve on the L.P. gas bottle.

CAUTION:

Do not attempt to operate any propane appliance while the trailer is in tow.

From inside the trailer, open and light one L.P. burner and allow to burn until flame extinguishes. This will safely and effectively bleed the system.

Turn L.P. burners to off. Lower the stove cover and secure for travel.

NOTE:

On Destiny models, ensure retaining pin is installed on stove bottom.

Drain all water in the sink and tighten basket strainer. Disconnect the waste system hose from the external trailer connection and replace drain cap.

Retract all mini-blinds and shades.

NOTE:

Mini-blind slats should be opened prior to raising the blind for storage in pouch.

Close all drapes completely and remove safety ties from curtain track located behind the galley.

Detach both front and rear bed bow supports from the roof retainer and from the bed bow and stow under each mattress.

NOTE:

Remove any accessories that are mounted to the top assembly (i.e., wardrobe rack, camper caddie, etc.) if the trailer is so equipped.

Lift the dinette table up on end. Apply inward pressure to the leg support locks and lower and secure legs by attaching the elastic cord over both dinette legs. Secure the dinette table by locating it on the rests between the bench seats. Store seat cushions on seat frame and backrest cushions face-down on the table.

From outside the trailer, begin at the top of the door frame and carefully pull the tent weather seal on either side of the door frame from the weather seal groove or mating hardwall velcro. Unfasten tent velcro patches from door frame and body rail.

NOTE:

Ensure removable window panes have been returned to their original position prior to storing screen door.

Step inside the trailer and release the door retainers. Lock the screen door latch. Lift up and remove the door from the threshold and move door inward.

From outside the trailer, grasp the bottom of the door frame, lift up and push the top of the door toward the far side of the trailer. Place the bottom of the door onto the pins on the retaining bracket and lock spring-loaded pin clip into base of door frame and snap web retaining straps. Be certain door is securely engaged on all three pins.

On Four Season models, from outside the trailer, gently pull the vinyl tent attachment away from the mating velcro and unsnap the tent section from the hard walls. Step inside the trailer. While holding the hard wall in place, starting on either side, turn the retaining locks 90 degrees to release the hard walls from the retaining brackets. Allow hardwall to tip inward. Repeat procedure for opposite wall.

NOTE:

Unlock center retaining lock last on each wall to prevent binding.

IMPORTANT:

Ensure all windows are closed and locked prior to closing the trailer for travel to prevent any inadvertent damage to the window or window screen.

Lower the galley to trailer floor.

From outside the trailer, release the exposed stretch cords from the hooks located under the extended bed. **Pull the stiffened corners of the tent out from between the bed and body rail.** Pull the tent up and over the bed edge. Grasp the bed bow and push toward the center of the trailer until it lays flat on the bed. Insure that the tent material is evenly distributed over the bed to facilitate closing of the top assembly. Raise the bed slightly and remove the bed support tube from the support peg. Swivel each support up and lock into the travel position. Return beds to travel position by placing hands on the bed frame and pushing inward until the bed hits the stops.

Set up the trailer tongue jack if it was previously retracted to the towing position.

CAUTION:

Be sure the tongue jack is supporting the trailer tongue and is locked in position to prevent sudden collapse of trailer tongue.

IMPORTANT:

Do not lower top unless the stabilizers are released.

CRANK-DOWN STABILIZERS

Raise stabilizers to travel position by rotating them counterclockwise.

WARNING:

Do not lie under the trailer when raising or lowering the stabilizers. Should the trailer fall, bodily injury could result if these warnings are not followed.

SWING-DOWN STABILIZERS

To raise the swing-down stabilizers, press on the quick release lever with the jack handle. Slide inner leg completely up and raise stabilizer to travel position.

WARNING:

Stand clear of the trailer when pressing on the quick-release lever for the trailer will drop when it is released. Do not lie under the trailer when releasing or lowering the stabilizers. Bodily injury could result due to the quick drop of the trailer if these warnings are not followed.

NOTE:

Ensure swing-down stabilizer is locked into the travel position.

POWER LIFT FOR AMERICANA SERIES/YOSEMITE AND HATTERAS MODELS

With the release valve in the fully closed position, lift up on the toggle switch momentarily to allow the lift cylinder to fully extend. Gently pull outward on the gravity release cable to disengage the gravity latch. Open the release valve completely by turning counterclockwise.

IMPORTANT:

The gravity latch must be released in order to lower the top assembly. Once the top begins to descend, the gravity release cable can be pushed inward to its original position.

Lower the top to within one foot of the trailer body. Close relief valve by turning completely clockwise.

PIONEER/DESTINY/CAPE COD MODELS

Rotate the crank handle in a counterclockwise motion and lower the top to within one foot of the trailer. On all models, tuck in any tent fabric which may have worked its way out between the rooftop and trailer. This is important because if the tent fabric is pinched between the top and the aluminum rail it can become worn or discolored. Lower the top down fully.

IMPORTANT:

If the top will not seat properly onto the trailer, DO NOT force it. Raise the top to approximately one foot and recheck tent distribution.

Close and lock the access door, and then latch the four top latches. Where applicable, ensure front trunk storage lid is securely latched and side access doors to trunk area are locked.

Adjust the tongue jack so that the trailer tongue is higher than the vehicle hitch ball. Back the vehicle close to the trailer and set brake. Using the tongue jack, lower the trailer tongue onto the ball hitch of the vehicle.

Engage the coupler release handle by pressing down into the locked position. The coupler has a hole in it for a safety clip or padlock to be inserted for trailer theft protection. Retract the tongue jack wheel fully by turning the handle counterclockwise until it stops, pull the release pin and swing the tongue jack up to the travel position. Bring the tongue jack handle up and over the tongue jack to store.

Attach the safety chains so they "crisscross" under the ball.

Connect the electrical pigtail to the mate.

Check to see that all lights on the trailer are functioning properly.

GAS SYSTEM

Liquid propane gas is used in your trailer for three basic reasons: it is inexpensive, portable, and burns with intense heat. This system has been checked at our factory and by your dealer to insure its safety. Except for the simplest maintenance, this system should be checked by an authorized L.P. gas supplier should any problems develop. Due to the importance of this system and the safety precautions built into it, we feel it best to take a little time to describe it to you.

GAS BOTTLE

The L.P. gas is stored under pressure in the gas bottle located on the tongue of your trailer. This bottle should be kept free of rust at all times. If rust should develop on the bottle, the area should be cleaned completely of the rust, primed, and repainted white. Quite naturally, the service valve on top of the tank should always be closed when the tank is not in operational use, and especially when in transit.

WARNING:

Do not smoke while changing the L.P. gas bottle and extinguish all surrounding open flames to avoid the possibility of fire and/or explosion.

NOTE:

Position L.P. tank with safety valve pointing away from trailer. Additional fittings are required as appliances are added i.e., water heater, furnace, refrigerator.

To change an L.P. gas bottle: Turn off the L.P. gas at all burners. Close the valve on the L.P. gas bottle by turning it in a clockwise direction. Disconnect the regulator to the L.P. gas bottle, using a suitable wrench.

NOTE:

Regulator threads are left hand threads. Turn counterclockwise to tighten/clockwise to loosen.

Loosen the wing nuts from the J-bolts and remove the empty gas bottle. Carefully place the full L.P. gas bottle on the tongue support and secure with the J-bolts and wing nuts previously loosened.

Using a suitable wrench, attach the regulator (with the vent facing down) to the L.P. gas bottle.

Open the valve by turning it in a counterclockwise direction slowly. Check for leaks by using a soap suds solution on all gas system fittings. **We suggest that all gas system fittings in the trailer be checked for leaks with a soapy solution each time a gas bottle has been changed, every 30 days, or after the trailer has tracked over rough terrain.** If the soapy solution is used and a leak is indicated by bubbles at a connection, tighten that particular connection sufficiently to stop the leak. If bubbles persist, close the L.P. gas bottle valve and contact your Fleetwood folding trailer dealer or L.P. gas supplier for assistance.

CAUTION:

Do not check copper and brass plumbing lines and fittings for leaks using ammoniated or chlorinated household type detergents. These can cause cracks to form on the line and brass fittings.

If a leak is suspected in the trailer, you will notice that L.P. gas has a distinctive odor. Should this be encountered, follow these directions:

1. Open the door and exit the unit, leaving the door open.
2. Close the valve on the L.P. gas bottle.
3. Do not touch electrical switches.
4. Extinguish any open flame.
5. Allow the trailer to ventilate thoroughly.
6. Check all stove valves to insure they are in the "off" position.
7. Check all pilot lights to make certain they are burning.
8. Check system for leaks by following steps outlined previously.

GAS BOTTLE REGULATOR

The gas bottle regulator is the heart of your L.P. gas system. It is an automatic device with working parts which move continuously. Consequently, it requires more care, protection, and attention than any other part of the system. The basic function of the regulator is to take a high and varied inlet pressure from the gas cylinder and reduce it to a safe and consistent low outlet pressure to the gas appliances. Whatever the pressure is in the gas bottle, and it will vary due to atmospheric conditions, the regulator's job is to reduce it to 6.35 ounces or 11" water column outlet pressure, and supply fuel downstream at this pressure in whatever volume is required to efficiently operate each appliance as the demand is made.

The regulator is equipped with a vent because it is constantly "breathing." That is, the diaphragm of the regulator moves down and draws air into the bonnet or adjustment spring housing. When the diaphragm moves up, the air is expelled through the vent. In the event that excess pressure builds up in the lower housing or body of the regulator, a relief mechanism vents it to the atmosphere. It is imperative, therefore, to check the vent frequently to be sure it is clean and free of water, corrosion, or obstructions as clogging is the most common cause of regulator malfunction. If the vent does become clogged, it can easily be cleaned with a toothbrush.

In addition, your regulator should be checked periodically by a competent L.P. serviceman to be sure that it is properly adjusted and in safe working condition. By following these simple precautions, your regulator will give you years of trouble-free service.

WARNING:

If the regulator vent becomes plugged, excessive pressure will cause the appliance to leak, making fire and/or explosion possible and causing subsequent damage to the appliance.

The regulator will function regardless of the position in which it is mounted; however, the recommended mounting position is with the vent vertically down or in a direct line opposite the inlet. If for any reason this is not possible, bear in mind that it is extremely important that the vent be pointed in a direction which results in the least likelihood of dirt, water, or other foreign materials getting into the regulator. It is also important to install the regulator in a position in which the cover cannot possibly become a receptacle for water or other foreign materials.

L.P. GAS REGULATOR FREEZE-UP

A regulator does not freeze, nor will L.P. gas; however, as the gas passes through the regulator, it expands and cools, and moisture in the gas or in the regulator will turn into ice. This ice can build up and totally or partially block the orifice and thus partially or totally block the fuel supply. There are a number of things you can do to prevent this type of freeze-up:

1. Before it is filled, Be sure the L.P. cylinder is totally free of moisture by drying any visible water around the valve area.
2. Be sure the cylinder is not overfilled. Insist that the bottle never be filled beyond 80% liquid level.
3. Keep the valves on an empty cylinder closed.
4. Have your L.P. dealer purge the cylinder if freeze-up occurs.
5. If necessary, have your L.P. dealer inject methyl alcohol in the cylinder.
6. Keep the cylinder in an upright position.

If a gas bottle is overfilled, a built-in pressure mechanism on the bottle will allow excess gas to escape. It is imperative, therefore, that once bottles have been filled that they always be stored outdoors in an upright position whereby complete ventilation is possible. As an example, if a bottle is filled during extremely low temperatures, an increase in temperature will allow the gas to expand and possibly trigger the release valve. The presence of this gas in a confined area could result in fire or explosion caused by exposure to an open flame.

WARNING:

The water heater and furnace combustion air exhaust ports may be extremely hot during water heater and furnace operation. Do not touch these outlets or allow any material to come in contact with, or cover, either the air intakes or exhaust ports while operating the water heater and/or furnace.

NOTE:

Preventative maintenance on all gas appliances should include periodically cleaning as needed to remove dust, lint, etc. from burner tubes and air passages. Burner tubes and orifices should also be inspected frequently for obstructions such as insects/spider webs or other foreign matter that may cause a burner malfunction.

For further details refer to respective appliance manual.

WATER SYSTEMS

When the campsite provides a pressurized water system: Remove the protective cap from the external pressure water connector. Attach a non-toxic garden hose (not furnished) between the external trailer connection and the (campsite-furnished) faucet.

IMPORTANT:

Since water pressures at campgrounds vary, we recommend you install an in-line pressure regulator (not supplied with trailer) at the water supply faucet. This will protect both the trailer water system and your supply hose from excessively high water pressure.

NOTE:

On **Americana models** the external pressure water connector is located within the utility hatch. To access, unlock hatch door with trailer key.

If the campsite does not provide a pressurized water system, it will be necessary to use the trailers internal water system. In order to fill the non-removable water storage tank of **Americana model trailers**, open the fill spout enclosed within the utility port door and slowly fill the tank using a non-toxic hose or appropriate container. On **Pioneer/Destiny model trailers**, the five-gallon water storage bottle/s can be removed from inside the trailer and filled at a suitable water filling station.

NOTE:

Certain **Pioneer models** have a non-removable water storage tank. These storage tanks will be filled identical to those of the Americana models.

Fresh water may be supplied to your trailer sink (and tub and shower unit where applicable) from one of two sources - the water tank or the city water hookup. Fixtures for both of these are located beside each other on the roadside body panel and are marked accordingly. When the city water is turned on, it will bypass the internal water tank with the exception of the water heater only. In order to be sure the water heater is filled, it is wise to open the hot water faucet slightly to allow the escape of trapped air.

WATER TANK

To insure complete sanitation of the potable water system, we suggest the following procedure be used on a new system, one that has not been used for a period of time, or one that has become contaminated.

Prepare a chlorine solution using one gallon of water and 1/4 cup of Clorox or Purex household bleach (5% sodium hypochlorite solution). Pour one gallon of solution into tank. Complete filling of tank with fresh water. Open the faucet until all air has been released from the pipes and entire system is filled. Pump water up to the sink. Allow to stand for three hours. Drain and flush with potable fresh water. To remove any excessive chlorine taste or odor which may remain, prepare a solution of one quart vinegar to five gallons water and allow solution to agitate in the tank for several days by vehicle motion. Drain tank and again flush with potable water.

NOTE:

The built-in water tank is equipped with a screen filter which is located in the outlet fitting or at the pump. The filter should be cleaned periodically to insure maximum pump efficiency. Contact your dealer for the removal of this filter.

Once the internal water system has been cleaned, flushed, and refilled, water can be pumped by raising and lowering the pump handle. When using the city water supply, **depress** the pump handle which will allow city water to flow freely.

Continual city water flow can be obtained by rotating the hold-down rod over top of the pump handle. This will allow for both hands to be free for kitchen type chores such as washing dirty dishes.

SINK DRAIN

The outlet port for the sink drain is located on the same side of the trailer as the sink and the location is identified with a "drain" decal affixed to the body panel. The sink can be drained by simply removing the plastic protective cap from this fitting and allowing the water to flow freely from the sink. Please note that this fitting is threaded to allow the fastening of a rubber hose in order to drain the sink into a park-provided facility or waste container.

12 VOLT ELECTRIC DEMAND WATER PUMP
(Trailers equipped with hot water only)

The electric pump can be activated for use by pushing the switch button located on the lower galley top. Once the unit is activated, it will automatically switch on and off depending upon water use. Instructions for the specific care, use, and service of this component are enclosed with your trailer. This electric water pump is only to be used when a city water hook is not available and water must be drawn from the storage tank and water heater.

IMPORTANT:

Do not allow the electric water pump to run when the water system is dry. Subsequent damage to the pump mechanism will result.

CAUTION:

Do not interchange waste system hose and fresh water hose as contamination to the water supply could result.

WATER SYSTEM VERSATILITY
(factory-installed water heater only)

The hot water system in your trailer is a high-quality, versatile system. To acquaint you with the various methods of operation, a discussion of each follows:

CITY WATER SUPPLY

Connect a garden hose (not furnished) to the campground-provided faucet and city fill fitting on the roadside panel of the trailer. Turn the city water supply "on" and allow the system including the hot water tank to fill. Light the water heater by following the instructions printed inside the vent cover.

IMPORTANT:

Be certain that the water heater is filled prior to lighting to prevent appliance damage.

Simply turn the sink or shower faucet knob approximately 1/4 turn to draw water.

USE OF THE WATER TANK WHEN CAMPGROUND CITY WATER SUPPLY IS NOT AVAILABLE

Fill the plastic water tank. Connect trailer exterior power cord to 110 VAC park supply and set the power converter to "convert." Engage the electrical demand pump by pressing the switch button located on the lower galley top. Once the hot water tank is filled and all faucets closed, the pump will automatically shut off. Light the water heater by following the instructions printed inside the vent cover. Simply turn the sink or shower faucet knob approximately 1/4 turn to draw water. The electric pump will automatically engage to provide needed water pressure.

When a 110 VAC power supply is not available, your water system may be used by connecting the trailer 12 VDC power supply to a tongue-mounted battery or tow vehicle outlet i.e., cigarette lighter.

WARNING:

The hot water drawn at the sink is directly out of the water heater. The temperature of the water could be as high as 150°. Scalding could occur if the hot water is not diluted. **DO NOT** expose the body directly to the undiluted hot water.

WARNING:

Hydrogen gas can be produced in a hot water system served by this heater that has not been used for a long period of time (generally two weeks or more). Hydrogen gas is extremely flammable. To reduce the risk of injury under these conditions, it is recommended that the hot water faucet be opened for several minutes at the sink before using any electrical appliance connected to the hot water system or lighting any gas appliance. If hydrogen is present, there will probably be an unusual sound such as air escaping through the pipe as the water begins to flow. **THERE SHOULD BE NO SMOKING OR OPEN FLAME NEAR THE FAUCET AT THE TIME IT IS OPENED.**

IMPORTANT:

Never attempt to light the hot water heater if it is not filled. Permanent damage to the heater unit could occur and such damage would void the warranty.

TROUBLE SHOOTING THE WATER SYSTEM

Water system problems usually fall into two categories: mechanical system problems and problems caused by neglect. System problems are usually the result of road vibration and campsite water pressure variations. Problems of neglect usually stem from failure to clean filters, improper winterization, and poor maintenance. Most water system problems can be avoided by conscientious maintenance.

LEAKS

Vibration, flexing, and twisting while traveling can work pipe fittings loose. If the water pump runs when a faucet is not open, suspect a leak. Be sure the tank drain valves are tightly closed. Leaks occur most often around threaded fittings. If necessary, tighten or clean and tighten the fittings. Do not over-tighten fittings. Connections at galley and lavatory fixtures should not be tightened with a wrench. They will normally seal with hand-tightening. If a leak persists at one of these fittings, disconnect it completely and check for mineral deposits or other foreign matter at the seating surfaces. Clean the surfaces thoroughly and reinstall the fitting.

CLOGGED WATER FILTER

Dirt, mineral scale, or organic matter are filtered out of the fresh water system by an in-line water filter on the inlet side of the water pump. If you suspect a clogged filter, it is easily removed and cleaned.

1. Loosen the clamp at the inlet of the filter
2. Pull the water line off the filter
3. Unscrew the filter from the water pump
4. Turn each end of the filter and pull apart
5. Flush out and clean screen
6. Reverse procedure to install
7. Operate the water pump and check for leaks

WATER PUMP TROUBLE SHOOTING

The water pump in your trailer is a durable device that will operate for years with little attention. Most water pump problems can be solved by a common-sense approach. The following is a discussion of possible trouble spots and what to do.

PUMP MOTOR DOES NOT OPERATE

Your trailer has two water pump switches - one master switch on the lower galley top and one in the pressure sensing assembly in the pump head. Be sure the "Water Pump" master switch is on. Even though the pump operates automatically when a faucet is opened, the pump master switch has to be on for that to happen.

Check the fuse. The water pump fuse is located in an in-line fuse holder near the pump. If it is blown, there is a reason for it. Check the pump wiring for shorts. Do not replace the pump fuse with a fuse rated for more than 7.5 amps.

Check for disconnected or corroded wires or terminals. Clean and reconnect if necessary. In cold weather, check for pump freeze up. If water is frozen in the pump, thaw it by placing a lighted bulb near the pump head. **Do not use a torch or other open flame.**

PUMP MOTOR RUNS BUT NO WATER FLOWS

Be sure there is water in the fresh water tank. Check the filter. If it is clogged, remove it and try cleaning it as a temporary fix. If that doesn't work, it must be replaced. Check inlet and outlet hoses and fittings. Look for kinked or collapsed hoses or loose clamps that could be letting air into the system. Avoid storing anything in the water pump area. A heavy item could flatten a hose or damage the inlet or outlet hoses and fittings.

PUMP RUNS BUT WATER SPATTERS

This is normal after an initial filling of the fresh water tank and lines. It should stop after a few seconds. If sputtering continues, the water tank may be almost empty. Add water if necessary. If sputtering continues, check for air leaks in the inlet side of the pump.

PUMP CYCLES ON AND OFF WHEN ALL FAUCETS ARE CLOSED

Check for leaks in the water lines. Be sure tank drain valves are tightly closed. The pump may have an internal leak.

PUMP DOES NOT SHUT OFF

Water tank may be empty. Check battery condition. A low battery will allow the pump to run but not develop enough pressure to shut off. The pump switch mechanism may be stuck. Gently tap the switch cap on the end of the pump with a screwdriver handle.

PUMP HEAD LEAKS

Tighten screws in the pump head assembly. **Do not over-tighten.** The head may be cracked. This can be caused by stress failure, but is more likely caused by water freezing in the pump head.

PUMP DOES NOT PRIME

Water tank may be empty. Filter may be clogged. Inlet hoses may be kinked or collapsed. Failure to prime may be caused by internal pump valve failure or foreign material lodged in a valve seat. These conditions require pump disassembly.

DRAINING AND WINTERIZING THE WATER SYSTEM

Your dealer can advise you concerning specific winterization procedures and products for your climate area or the areas through which you will be traveling. Your dealer may also provide winterization service for all appliances and systems in the trailer.

If you choose not to travel during the winter and will be storing your trailer during periods of freezing temperatures, follow a thorough winter storage procedure.

Protecting the plumbing systems in your trailer is the most important aspect of long-term winter storage. Extensive damage to the plumbing fixtures and components as well as other potential problems can be avoided by proper draining and antifreeze protection. The following is a procedure checklist you can follow if you prefer to winterize your vehicle yourself.

Drain the fresh water tank by opening the water tank drain valve. Leave valve open. Turn the water pump on (12 volt DC power on). Open a cold water faucet. When the flow of water stops, turn the pump off. After opening hot and cold water faucets, open the drain valves on HOT and COLD water pipes. These valves are located on the underside of the trailer directly in front of the axle. (Water line drain valves only applicable in trailers so equipped.) Drain the water heater by opening the drain valve at the bottom of the heater and open the safety valve. Open the hot water faucets. Note water heater instructions for exact location of drain valve. When each faucet has been opened, drained, and closed, close the water line drain valves and freshwater tank drain valve. Disconnect the shower hose assembly. Be sure ALL water from ALL plumbing fixtures has been drained.

On units not equipped with a water heater or tub and shower unit, the water system may be drained by simply turning the petcock located on the bottom of the water storage tank under the trailer and allowing all water to drain out.

On those units equipped with water bottles and not an installed tank, it is only necessary to drain the lines and simply empty the bottles.

CAUTION:

Draining the water system alone will not provide adequate cold weather protection. If the trailer is to be unheated during freezing temperatures, consult your dealer for the best winterizing procedure for your climate. Your dealer can winterize your trailer for you or can supply you with one of the special antifreezes which are safe and approved for use in RV water systems. Follow the instructions furnished with the antifreeze.

WARNING:

Do not use automotive or windshield washer antifreeze in the trailer water system. These could be harmful if swallowed.

Pour approximately two gallons of approved RV water system antifreeze into the fresh water tank. Be sure tank drain valve is closed. Turn the water pump master switch ON. Open each cold water faucet, run the water pump and let about a cup of antifreeze solution flow continuously through each faucet. Close each cold water faucet. Check the antifreeze level in the water tank. Add antifreeze solution if necessary.

On trailers equipped with a water heater bypass, turn the water pump switch OFF. Completely drain water tank and water heater. Open water heater relief valve to drain water heater. Pour approximately two gallons of non-toxic RV-approved antifreeze into fresh water tank. Open all hot and cold water faucets to relieve pressure. Close all faucets. Engage water heater bypass connection. This can be achieved by disconnecting the two swivel elbow connections from the water heater, (hot & cold lines). Attach bypass line onto the two swivel connections. Turn water pump ON. Open hot water faucet farthest away from water tank. When antifreeze appears, let about one cup run down drain to winterize trap. Repeat this at all other hot and cold water faucets including the shower. Turn water pump OFF. Open water faucet to relieve pressure then close. Winterizing of the fresh water system is complete.

When filling the plumbing systems with antifreeze, be sure to open and operate all fixtures and valves allowing the antifreeze solution to flow freely. Pour a cup of antifreeze solution down each sink and tub drain. Install all protective caps: water tank fill; city water inlet cap.

TRACKING SYSTEM

TIRES

CAUTION:

To provide maximum towing ease, tire life, and trailering safety, check the following items before each trip to and from the campsite:

1. Tires inflated to recommended pressure as indicated on the tire sidewall.
2. Wheel lugs securely tightened (70-80 footpounds for 8" tires; 80-90 footpounds for 10"/12" tires).
3. A visual inspection of tire tread and walls for wear or cuts.
4. Trailer is being towed as level as possible with tow vehicle.

PLEASE NOTE:

The tires on the Fleetwood folding trailer are warranted separately by the manufacturer. While the warranties of the various tire manufacturers vary in language, they in general provide that tires installed as original equipment at the factory are warranted to the owner to be free from defects in material and workmanship for one year after the retail sale or 33% of the tread wear, whichever occurs first.

There is no warranty coverage for damages resulting from road hazards, improper inflation pressures, driving more than the maximum speed limit, or overloading the trailer beyond the maximum load capacity.

If a tire warranty adjustment is required, the trailer owner should contact the nearest authorized Fleetwood folding trailer dealer. In the event there is no local dealer, the customer should follow the directions set forth in the tire warranty card packaged in each folding trailer or call DURO, 800-966-TIRE. A Fleetwood folding trailer dealer MAY be able to assist you in handling warranty adjustments.

NOTE:

Not all Fleetwood folding trailers are capable of accepting different size tires. Prior to making any tire size changes, consult your dealer for tire size adaptability.

HOW TO CHANGE A FLAT TIRE

Tires can be changed using the following procedure. For safety purposes, turn on the vehicle hazard warning flashers. Block both front and back sides of the tire opposite the one needing changing. Remove the hubcap from the tire you wish to change. Using a 13/16" lug wrench, break loose the lug nuts. Raise the trailer using a scissor or hydraulic jack. **Do not utilize the stabilizer jacks as a means of lifting the trailer weight.** The jack should be placed directly underneath the main frame bar and NOT on the axle beam. Take the lug nuts off using the lug wrench. Slide the flat tire off and slide repaired, new, or spare tire onto the axle. Start each lug nut by hand to avoid cross-threading and then use the lug wrench to draw the lug nuts reasonably tight. Lower the jack until the tire is on the ground. Using a lug wrench, draw the lug nuts tight (70-80 footpounds for 8" tires; 80-90 footpounds for 10"/12" tires). Replace hubcap.

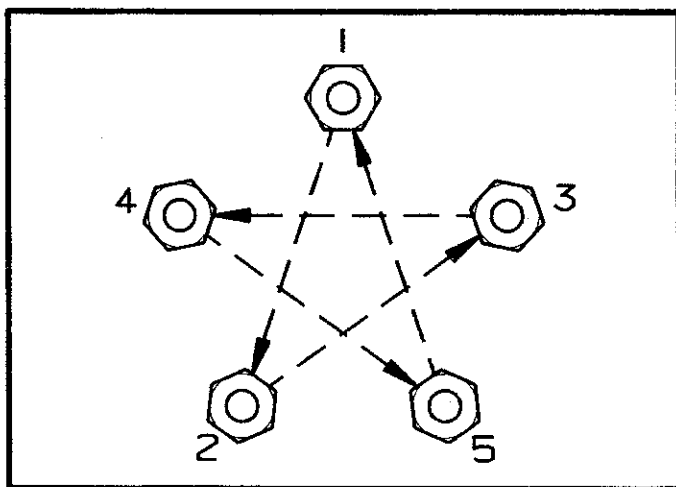

TORQUE CHART

CAUTION:

After you have driven a short distance (approximately one or two miles), stop and recheck the lug nuts to insure they are securely tightened. Check again after 25 miles.

BRAKES (where applicable)

Brakes should be adjusted after the first 200 miles and at 3,000 mile intervals, or as use and performance requires. For brake adjustment and maintenance, please refer to Dexter Brake Manual supplied in the trailer information packet.

BREAKAWAY SWITCH (where applicable)

The breakaway switch is located on the trailer tongue. It has a steel cable (lanyard) fastened to it which will reach to the frame of the tow vehicle. This device is one of the most vital components on your trailer's braking system. It automatically applies the trailer brakes if the tow vehicle and trailer become uncoupled while in motion. The breakaway switch operates when a pull pin linked by the cable to the tow vehicle is separated from the switch. When the switch closes, power for brake application is transferred to the on-board trailer battery. The steel lanyard must be anchored to the tow vehicle when the trailer is hitched up. Secure this cable loop to the permanent frame of the tow vehicle or a part of the hitch that is non-removable. **Do not fasten the breakaway switch lanyard to the hitch ball or any other removable part of the hitch.** Remove the pull pin every three months and lubricate it with light oil. Before reinserting the pin, spray the inside of the switch with an electrical contact cleaner to prevent corrosion.

Test the breakaway switch operation before each trip as follows:

1. Hitch the trailer to the tow vehicle.
2. Pull out the breakaway switch actuating pin.
3. Test brakes by attempting to drive away. The breakaway switch is functioning properly if the trailer brakes are activated.
4. If the brakes are not activated, check that the trailer battery is connected and fully charged and the trailer brakes are properly adjusted.
5. Obtain service repair if the trailer brakes do not operate after making these checks.
6. Reinsert the breakaway switch actuating pin before towing the trailer.

WARNING:

Do not tow a trailer with a malfunctioning breakaway switch.

WARNING:

Do not leave the pull pin out of the breakaway switch for more than a few minutes or the battery will be drained. Do not use the breakaway switch as a parking brake.

BALL HITCH AND COUPLER

All trailer models are equipped with a 2" ball coupler.

Maintain a coat of light grease on the ball hitch of your vehicle. This will induce longer ball hitch life and towing ease.

The coupler should be adjusted, when required, to maintain the coupler/ball snugness. With the coupler attached to the ball and the coupler release handle down in the locked position, adjust the lock nut (on the underside of the coupler) to compress spring to within 1/32" of solid.

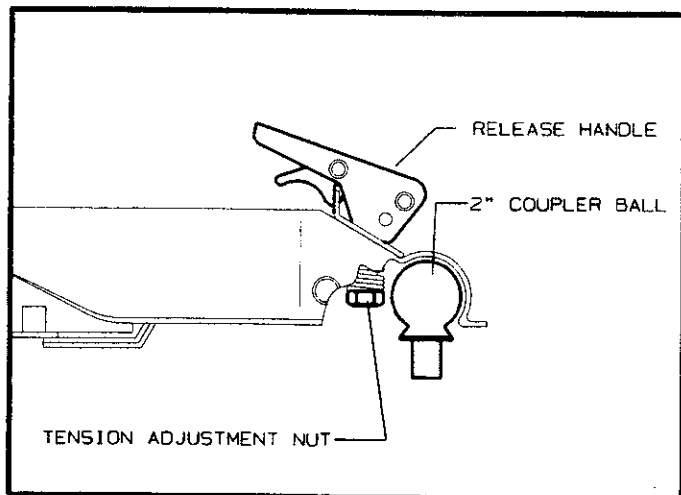

COUPLER

Make a visual inspection of the safety chains for damaged or corroded links; repair or replace as required. Insure the ball hitch is securely attached to the vehicle and the ball head is securely tightened.

RECOMMENDED PRACTICES FOR LUBRICATING AND ADJUSTING WHEEL BEARINGS

IMPORTANT:

Wheel bearings should be checked before the initial camping trip and then every 2,000 miles or twice a season, whichever occurs first, and at the beginning of each camping season.

LUBRICATION

Re-lubrication of wheel bearings is the most important service performed to the running gear. The two most important phases of this operation are cleanliness and proper adjustment.

Before disassembly of the hub, check wheel play and freedom of rotation. Extreme or excess play indicates a too-loose adjustment or a defective bearing. Too much drag in rotation of the hub could indicate tightness in bearing adjustment or a brake being adjusted too tight.

To begin disassembly, remove the dust cap. Next, remove the cotter pin and spindle nut. Jiggle the hub slightly to loosen the outer bearing. Usually the outer bearing will loosen up enough to be removed by hand. Pull the entire hub which contains the inner bearing and grease seal. Remove the inner bearing and grease seal by placing a brass drift or piece of wood through the small end of the hub and tapping gently until the bearing and seal is loose. Wipe all dirt and grease from the inside of the hub and the spindle.

Used bearings must be cleaned prior to lubrication.

Various solvents are effective for degreasing. Successful processes employ kerosene, distillates, and chlorinated hydro-carbons. The solvent action of kerosene is limited, but it has the advantage of leaving a rust-inhibitive film on the bearing. After cleaning, bearings should be allowed to drain free of solvent which might dilute lubricants. Do not immerse the grease seal in any solvents, but wipe clean with a cloth.

WARNING:

Do not use above-described cleaning solvents near or around open flames as fire or explosion could occur resulting in serious bodily injury.

Carefully inspect cups (races) and cones (bearings) for pitting, scratches, excessive wear, or other damage. Do not replace a bearing unless you also replace its mating cup.

If at all possible, use a bearing packer to repack the cones. Using a high temperature wheel bearing grease, the bearings can be lubricated by hand if the grease is pressed into and around each and every roller. Additional grease within the hub is not required. Install the inner bearing in the hub and replace grease seal by tapping gently with a wooden block, making sure the seal is installed as it was before disassembly. Replace hub on spindle, taking care not to damage threads or grease seal. Replace outer bearing and spindle nut. Slowly rotate the hub in one direction or the other while tightening the spindle nut (maximum 50 footpounds torque) or until there is a slight bind to be sure that all bearing surfaces are in contact.

At this point the adjusting nut is backed off 1/6 to 1/4 turn or to the nearest locking hole or castellation. This will allow the wheel to rotate freely without excessive end play. By pushing inward and pulling outward on the hub several times a person should feel a very slight end play. If the bearings are too tight or too loose, they will fail prematurely. Install new cotter pin, bend to locked position, and drive on grease cap.

LIFT SYSTEM

Never crank the trailer up with weight on the roof except for a dealer-installed air conditioning unit. Additional weight placed on the top assembly while the unit is being cranked up can result in an unnecessary strain on the lift system causing cables to be stretched and the loss of proper height adjustment. Never raise or lower the roof with the stabilizer jacks set. This action can cause a bind on the trailer frame resulting in excessive pressure being placed on the four lift assemblies.

MAINTENANCE

The only maintenance that will be necessary to perform to your lift system is an occasional lubrication of the pulleys contained within the lifts. This lubrication should be only a silicone spray and used very sparingly.

NOTE:

Excessive lubrication on the pulleys or lubrication on the lift arms can result in unsightly stains to the tent enclosure.

TOP ADJUSTMENT

(Pioneer/Destiny/Cape Cod models)

Height adjustment, if necessary, can be performed at each main cable adjustable pulley bracket. One bracket is located in each corner of the main frame tube area.

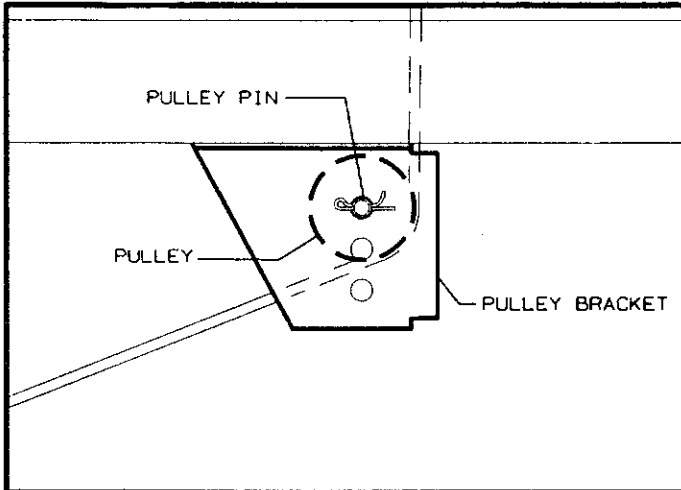

ADJUSTABLE PULLEY

Crank top to approximately 12" high. Extend front and rear bed assemblies approximately one foot past body rails. Lower top down on extended beds until crank stops to relax cables. Remove pulley pin and relocate pulley to an alternate hole position. (Each hole should add about 1 1/2" to that particular corner or a maximum of 3" adjustment available at each corner. Do not over-adjust or canvas and weather seals may be damaged.) Raise top and return beds to travel position.

NOTE:

Fine adjustments can only be performed at the main drive train area. This adjustment should be performed by an authorized Fleetwood folding trailer dealer.

NOTE:

Top height adjustment on **Americana, Yosemite and Hatteras model trailers** power lift must be performed at the hydraulic cylinder. These adjustments should be done by an authorized Fleetwood folding trailer dealer.

IMPORTANT:

We emphasize that any customer repairs to the lift system should only be done as a temporary measure. Your dealer should be consulted prior to performing any lift system service to prevent inadvertent damage to the system.

TENT ENCLOSURE

SUNBRELLA 302 FABRIC

Cleaning

Acrylic fabric is made from 100 % solution dyed acrylic fiber. When acrylic fabric is stored, it should be cleaned, allowed to air dry and stored in a dry, well ventilated area.

Acrylic fabric should be cleaned regularly before substances such as dirt are allowed to accumulate on and become embedded in the fabric. The fabric can be cleaned without being removed from the installation. Simply brush off any loose dirt. Hose down and clean with a mild solution of natural soap such as Lux or Ivory in lukewarm water (no more than 100 degrees F). Rinse thoroughly to remove soap.

NOTE:

DO NOT USE DETERGENTS.

If the fabric indicates slight water leakage as a result of residual soap, repeat rinsing. A second alternative is to treat the fabric with a water repellent such as Scotchgard Fabric Protector.

Mildew Removal

Solution-dyed acrylic does not promote mildew growth. However, mildew may grow on dirt and other foreign substances that are not removed from the fabric. To clean mildew stains, prepare a mild solution of one cup Clorox, plus two cap-fulls of Ivory Liquid or Joy per gallon of water. Spray on entire area and allow to soak in. If necessary, scrub vigorously with a sponge or clean rag. Sponge thoroughly with clean water and air dry.

EVOLUTION 3 FABRIC

Evolution 3 fabric can get dirty and or dusty and some contaminants can affect the fabric's natural water resistance. Either condition can be taken care of by properly cleaning the fabric.

NOTE:

A loss of water resistance can be detected by hosing the suspected area with water. If the fabric easily absorbs the water or if water droplets appear on the other side, the fabric may be contaminated and is in need of cleaning.

Evolution 3 fabric is hand or machine washable following the guidelines listed below. Hand cleaning is recommended for small isolated areas. Machine washing is a convenient method to clean an entire tent section.

Cleaning

In a clean bucket, mix a solution of 2 gallons of warm water with 12 ounces (1 1/2 cups) of Fantastik All Purpose Cleaner.

The cleaning solution may be cut back as follows: 1 gallon water/6 ounces cleaner, 1/2 gallons of water/3 ounces cleaner, 1 quart water/1/2 ounce cleaner.

With a clean, soft brush, apply the solution to the contaminated area only (to minimize rinsing/drying time, try not to get the solution on the surrounding fabric). Gently work the solution into the contaminated area.

Slowly rinse the area from top to bottom in a back and forth motion. Be sure to rinse thoroughly until all the cleaning solution is removed.

Leave the fabric to air dry on the trailer or tent section may be removed and suspended from a clothesline for drying.

If the fabric indicates slight water leakage as a result of residual soap, repeat rinsing. A second alternative is to treat the fabric with a water repellent such as Scotchgard Fabric Protector.

Rinse Cleaning

A simple cleaning method to remove light dust is to rinse off the tent enclosure while on the trailer.

NOTE:

All washing of tent enclosure material is the consumer's responsibility and is not covered under normal warranty procedure. If the above procedures do not correct the leak, contact your nearest authorized Fleetwood folding trailer dealer for assistance.

MILDEW REMOVAL FROM VINYL AREAS OF TENT ENCLOSURES

Open the folding trailer to full height.

Extend both bed assemblies and place bed supports onto the appropriate bed pins.

Place the canvas support poles into the top assembly tent support brackets and bed bows. Extend support poles until canvas is tight.

Secure Evolution 3 around perimeter of bed assemblies with the shock cord.

Remove mattress assemblies from unit.

Spray X-14 mildew stain remover on a sponge or cloth and apply to interior contaminated areas of bed vinyl material. Allow to air dry. (Mildew will start to fade as the X-14 dries.)

CAUTION:

X-14 is a caustic liquid which can discolor some fabrics and cause deterioration of natural fabrics. Follow directions and cautions on container prior to use. Spray X-14 on sponge or cloth outside the folding trailer. Surfactant within cause Evolution material to leak. Use X-14 in a well ventilated area.

Rinse area with a sponge and clean water. Allow to air dry.

Apply a generous coating of mildew disinfectant to bed vinyl material to inhibit the return growth of mildew contaminants.

The problem in treating mildew is it varies in degrees of strength. The longer the fungus spreads without treatment, the more impregnated the stains become within the vinyl material. Eventually, without treatment the stains will not clean out, requiring replacement. Therefore, it is imperative that treatment be administered quickly to minimize contamination.

CONDENSATION PREVENTIVE MAINTENANCE

The relatively small volume and compact construction of a modern recreational vehicle mean that the normal living activities or even a few occupants will lead to rapid moisture saturation of the air contained in the trailer and the appearance of visible moisture, especially in cold weather.

The air inside a recreational vehicle can contain a surprisingly large amount of water vapor. Estimates indicate that a family of four can vaporize up to three gallons of water daily through breathing, cooking, bathing, and washing. Unless this water vapor is carried outside by ventilation, it will condense on the inside of the tent enclosure as moisture.

If you know the signs of excessive moisture and condensation, you can minimize their effects during cold weather by the following:

1. Ventilate with outside air. Partially open one or more windows to provide controlled circulation of outside air into the interior. While this ventilation will increase furnace heating load, it will greatly reduce or eliminate water condensation.
2. Provide more ventilation while cooking is being done inside the camper.
3. Insure adequate ventilation in areas where condensation problems are experienced.
4. The use of an electric circulating fan or a small dehumidifier inside the camper will noticeably reduce condensation.

NOTE:

Even when it is raining or snowing, ventilation air from outside will be far drier than interior air and will effectively reduce condensation.

VINYL BED END COVERS

The exterior vinyl over the bed areas can be cleaned by using cool water and a soft bristle brush or cloth. Rinse thoroughly with cool water and allow to dry. When necessary, automobile convertible top cleaners can be used to remove stains. Care should be taken not to allow the vinyl cleaner to come in contact with the Evolution 3/Sunbrella 302 material or leakage may result.

IMPORTANT:

Follow the manufacturer's instructions carefully for use of such cleaners or damage to the vinyl surface could occur.

CAUTION:

The use of insect repellents, hair sprays, and deodorants inside the folding trailer when sprayed on the tent surfaces will cause a breakdown of the water repellency of the fabric. We suggest, therefore, the very limited use of such sprays inside the unit during camping.

The zippers on your tent can be lubricated by using a paraffin wax. The use of paraffin on the zippers will enhance their ease of operation around the tent sections and windows.

ROOF-MOUNTED ACCESSORIES

Periodic maintenance should be performed to all roof-mounted accessories. Check all sealant of accessory attachment point to roof assembly. Cracks or voids in sealant can lead to water damage to roof and interior components.

ROOF-MOUNTED AIR CONDITIONERS

An optional roof-mounted air conditioner can operate only when the trailer is connected to 110 VAC power from either a public utility or a generator. Routine maintenance for a roof-mounted air conditioner should include inspecting the ceiling assembly attachment bolts after each trip to ensure the bolts have not loosened or backed-out due to road vibration. For further maintenance on your air conditioner, follow the manufacturer's recommendations as outlined in the air conditioner owner's manual.

ELECTRICAL

When the campsite provides an electrical system: On **Four Season, Pioneer, and Destiny models**, lift up the cable hatch cover, grasp the self-storing power cord plug, and pull it out. The **Americana models** electrical cord is stored within an outside storage compartment. Plug the power cord into the campsite-provided outlet. From inside the trailer at the power supply center, set the converter selector switch to the "CONVERT" position.

WARNING:

The electrical system is rated for a maximum 30 amperes normal household-type current. Be sure not to exceed this rating. Excessive amperage draw could cause electrical system problems. Be sure any outlet the trailer is plugged into is grounded and has the correct polarity.

CONVERTER

The converter changes the 110 volt park supply to 12 VDC for operation of the interior 12 volt lights and certain 12 volt appliances (i.e., furnace).

This 12 VDC is not a stable or "clean" voltage and may not be suitable for use with appliances such as television monitors. The receptacles inside the trailer carry the 110 volt current for operation of 110 volt appliances and the like. Set the converter selector switch in the "convert" position for this type operation.

When the converter is set to "BATT," the interior electrical lights must be serviced by an external 12 volt battery for the electrical supply. This external battery could be the tow vehicle battery or an auxiliary battery.

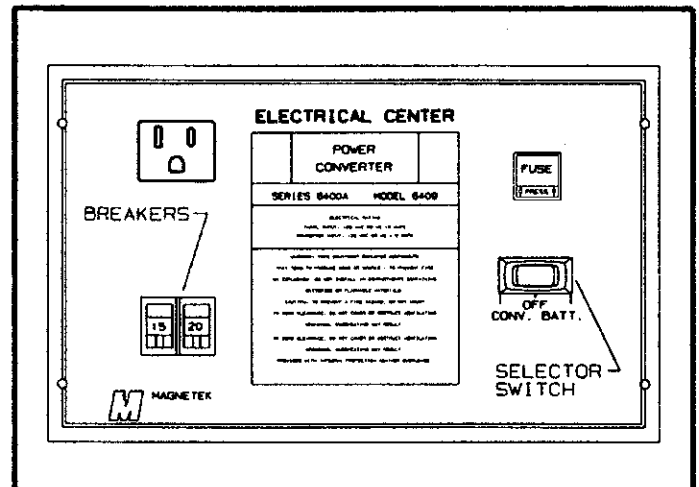

TRAILER CONVERTER

NOTE:

If the converter is not plugged into a 110 VAC source, the 110 VAC outlet within the trailer will not operate.

NOTE:

The converter contained within the trailer will not recharge a tongue mounted battery.

WARNING:

Do not use or store a battery inside the trailer. Battery acid leakage or explosion could cause bodily injury or death.

On the tongue of the trailer are two 12 volt DC wiring harness connectors. The main harness is a female connector which connects to the tow vehicle for the operation of running lights, brake lights, and so forth. Each model also has a two-prong connector which is for the operation of the 12 volt interior lighting system and optional furnace. In order to use the two-prong receptacle, it is necessary to purchase the 12 volt auto extension cord from your dealer. This cord may be plugged into the tow vehicle cigarette lighter or to an auxiliary battery to provide 12 volt power to the interior of your camper.

IMPORTANT:

Never allow the 12 volt, two-prong receptacle to be plugged in while the trailer is in the closed position. Excessive heat build-up in the interior lights could cause damage to the tent material of your camper.

All model trailers are equipped with a **12 VDC in-line kill switch**. This switch is located on the lower galley top.

When the galley is raised to the upright position, the switch will activate thus allowing power to be supplied to the interior top lights.

CAUTION:

Ensure interior top lights are turned to the "OFF" position when closing the trailer in the travel position.

The electrical system of your folding trailer is broken down into two separate and distinct functions - the 12 volt direct current and 110 volt alternating current.

12 VOLT VEHICULAR ELECTRICAL CIRCUIT

The 12 volt DC electrical circuit is dependent on the tow vehicle's battery or an auxiliary battery. Frequent and regular checks of the battery should be made to assure electrical system stability. We suggest the following checks:

1. Battery terminals and posts free from corrosion.
2. Battery terminals securely fastened to the battery posts.
3. Battery water level.
4. Battery voltage at the level specified by the battery manufacturer.

Before each trip, make an operational check of all DC electrical functions of the trailer: turn, stop, side marker, and taillights. If a bulb does not light, remove the lens cover from over the bulb not functioning. Most often, bulb replacement will cure the malfunction; however, should the malfunction persist, secure the aid of a voltmeter and the wiring diagram contained herein and check the DC voltage and/or continuity of the circuit. Repair or replace as required.

110 VOLT AC POWER SUPPLY

The 110 volt AC power cord can be plugged into a park supply power source for the operation of interior and exterior receptacles only. The converter will change the 110 volt AC park supply to 12 volt DC current for interior lighting and optional furnace operation.

All Americana, Pioneer, Four Season, and Destiny model trailers are equipped with a 110 volt AC exterior outlet for your convenience. This outlet is wired in series with a Ground Fault Interrupter. This device is intended to protect you against the hazards of line to ground electric faults and electrical leakage shocks. Materials used to insulate appliances and devices can deteriorate over time or develop cracks or weak spots that could allow electric current to "leak" through the insulation. Should a circuit or appliance develop a potential shock hazard of this type, the GFI device is designed to disconnect the outlet (and other outlets on the same circuit), limiting your exposure time to the shock hazard caused by current leakage to ground.

The GFI device does not prevent electric shock, nor does it protect a person who comes into contact with both "hot" and neutral sides of the circuit. It does not protect against electrical circuit overloads.

Test the GFI at least once a month while operating on 110 volts AC. To test the GFI:

- * Push the "TEST" button. The "RESET" button should pop out, indicating that the protected circuit has been disconnected.
- * **IF THE "RESET" BUTTON DOES NOT POP OUT WHEN THE TEST BUTTON IS PUSHED, A LOSS OF GROUND FAULT PROTECTION IS INDICATED. DO NOT USE THE OUTLET OR OTHER OUTLETS ON THE SAME CIRCUIT. HAVE THE TRAILER ELECTRICAL SYSTEM CHECKED BY AN AUTHORIZED FLEETWOOD FOLDING TRAILER DEALER OR BY A QUALIFIED ELECTRICIAN. DO NOT USE THE SYSTEM UNTIL THE PROBLEM HAS BEEN CORRECTED.**
- * To restore power push the "RESET" button.

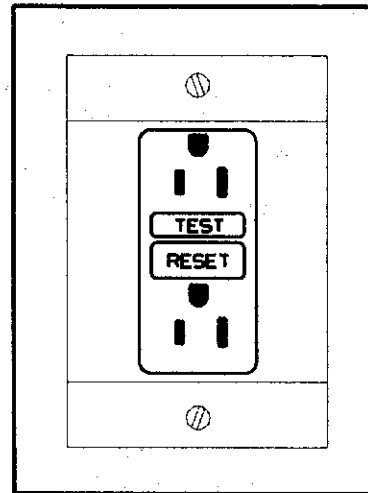

GFI RECEPTACLE

NOTE:

If the exterior outlet doesn't work, check the GFI. Reset it if necessary. If the GFI continues to trip, have the trailer electrical system checked at an authorized Fleetwood Folding Trailer Dealer or by a qualified electrician.

**4 PRONG
DESTINY SERIES
WIRING DIAGRAM**

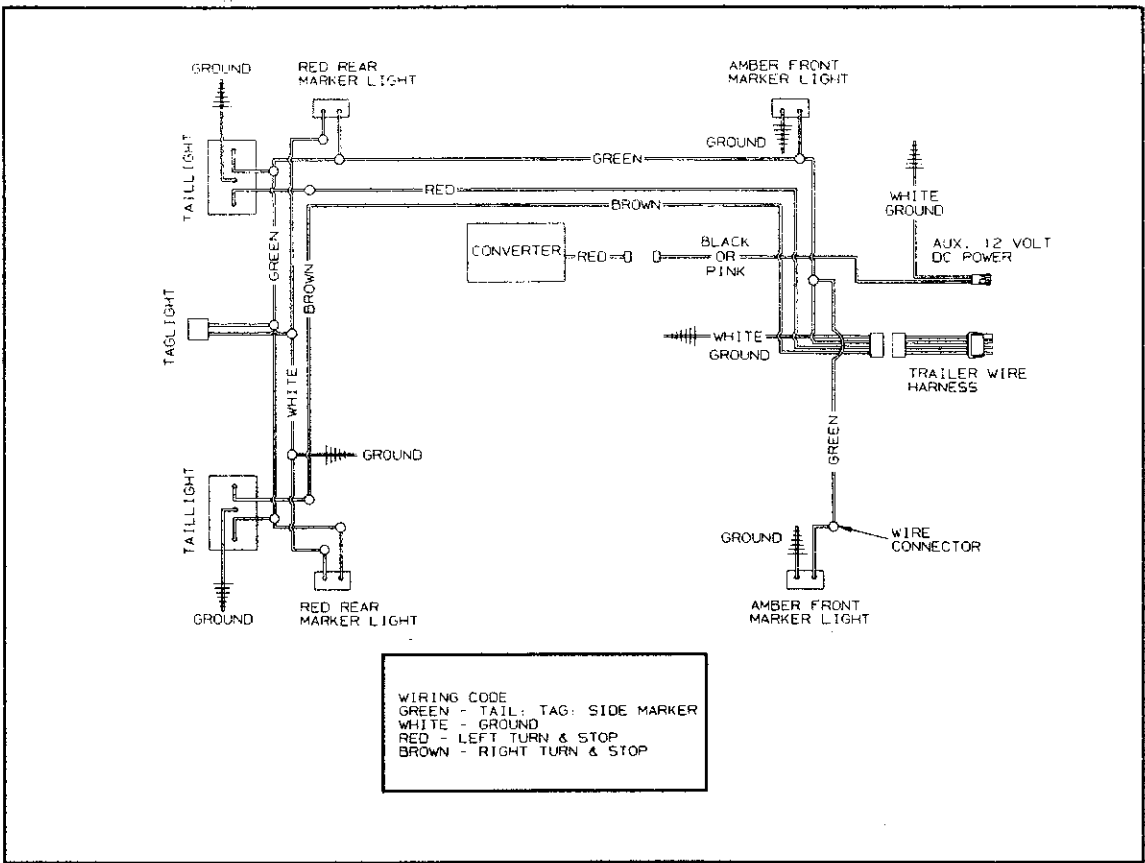

**6 PRONG
DESTINY SERIES
WIRING DIAGRAM**

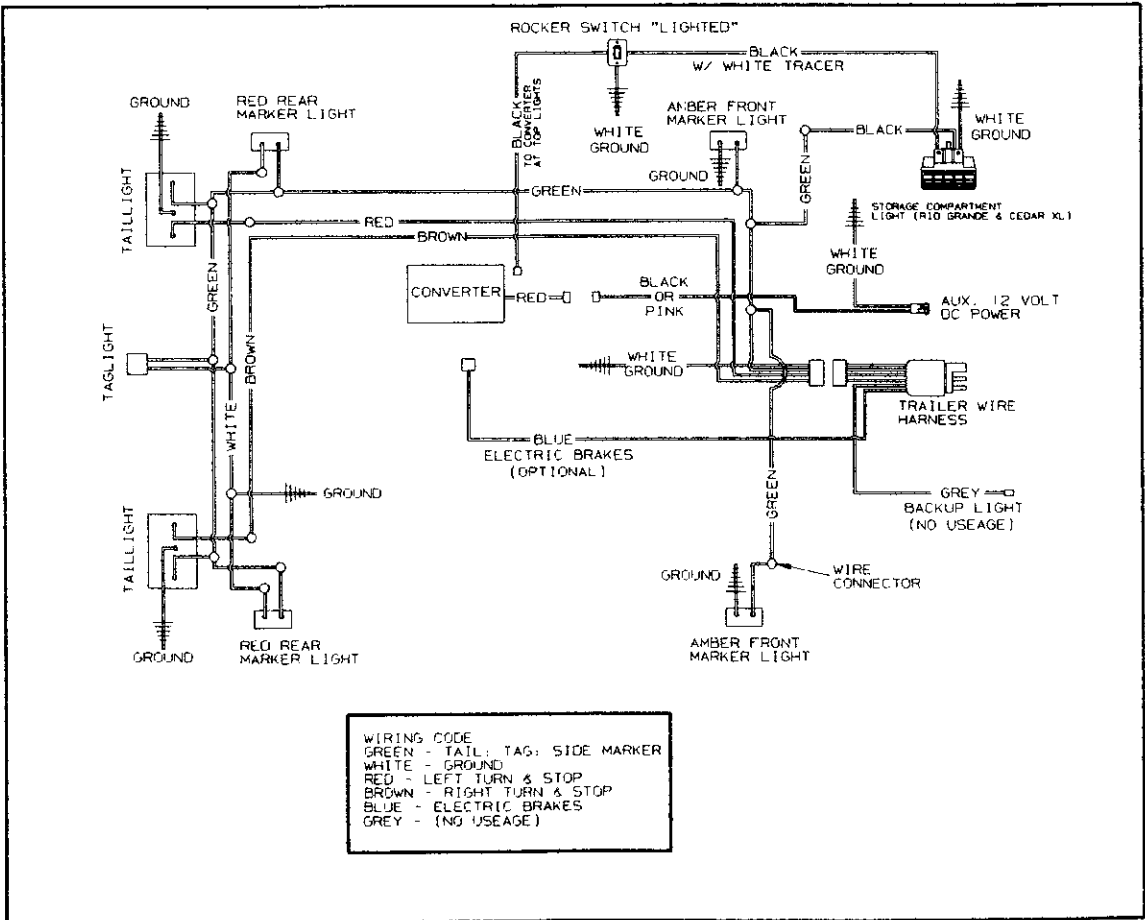

MAINTENANCE CHART

SERVICE TO BE PERFORMED	BEFORE EACH TRIP	MONTHLY	EVERY 3 MONTHS	ANNUALLY OR BEFORE LONG-TERM STORAGE	ANNUALLY OR AFTER LONG-TERM STORAGE	AS NEEDED
Inspect safety chains	○					
Inspect trailer/tow vehicle wiring connections	○					
Inspect hitch components	○					
Test break-away switch	○					
Inspect tires for wear	○					
Check tire pressure	○					
Check wheel lug nut torque	○					
Check exterior lighting	○					
Inspect LP gas components	○					
Inspect A/C ceiling assembly bolt tightness	○					
Inspect and clean battery, cables, and terminals		○				
Check fire extinguisher		○				
Test GFI		○				
Wash exterior (trlr. closed)		○				
Inspect and clean water pump filter		○				
Inspect exterior roof sealants			○			
Lubricate lift arm pulleys				○		
Winterize water system and drains				○		
Lubricate bed slides					○	

MAINTENANCE CHART

SERVICE TO BE PERFORMED	BEFORE EACH TRIP	MONTHLY	EVERY 3 MONTHS	ANNUALLY OR BEFORE LONG-TERM STORAGE	ANNUALLY OR AFTER LONG-TERM STORAGE	AS NEEDED
Inspect brakes					X	
Sanitize fresh water tanks					O	
Lubricate coupler & latch					O	
Complete LP gas pressure and system check					X	
Repack wheel bearings (every 2000 miles)					X	
Clean tenting						O
Clean interior						O

"X" Indicates items that should be performed by qualified personnel with appropriate equipment.

STANDARD CARE ITEMS AND RECOMMENDED CLEANING AGENTS

Stove and sinks	Appropriate household cleaners
Countertops	Warm soapy water
Bathtub	Non-abrasive household cleaner
Cooler	Mild soap and water
Drapes and valances	Dry clean only
Mattress covers	Foam type cleaners and vacuum
Cushion/backrest covers	Foam type cleaners and vacuum
Table top	Damp cloth
Vinyl windows	Warm water and mild detergents
Vinyl floor covering *	Water and mild soap
ABS panels	Mild soapy water
Sliding glass windows	Suitable window cleaners

* To keep your vinyl floor covering looking new, it is advisable to place a throw rug or carpet on the floor covering directly underneath the area in which the hinged or free-standing galley will rest during transit.

WINTER/OFF-SEASON STORAGE

When storing your Fleetwood Folding Trailer for extended periods of time, the following steps should be observed:

1. Winterize water system and turn off L.P. gas at tank valve.
2. Angle trailer tongue end slightly downward to eliminate water, snow, or ice build-up on top assembly.
3. If trailer is equipped with roof mounted accessories, open bi-monthly to ensure all accessory seals are functioning.
4. Tarp coverage over entire trailer is not recommended. Lack of air circulation within a closed trailer can lead to excessive condensation build-up.
5. Do not store trailer in tall grass, weeds, or near wood piles.

1995 LIMITED WARRANTY FLEETWOOD FOLDING TRAILER

Your new Fleetwood folding trailer is warranted to the original retail purchaser to be free from defects in material and workmanship for one year from the date of retail purchase. This warranty is not transferrable.

1. **The lift system** (used to raise and lower the roof) is warranted to the original retail purchaser for his or her lifetime against functional defects in material and workmanship. This warranty covers both parts and labor with the following **exclusions**:
 - * Normal adjustments to the lift system (such as periodic roof height adjustment to compensate for stretch in cables) are covered for the first year of this warranty only.
 - * The installation of a roof air conditioner and/or any other roof-mounted accessories and cargo cannot exceed 150 pounds. Exceeding this limit voids the warranty provision on the lift system.
 - * Any damage resulting from alterations to the lift system.
 - * Any damage caused by improper maintenance, improper repair, or by use of improper repair parts.
 - * Hydraulic hoses are covered for the first three years of this warranty only.
2. **The floor** is warranted to the original retail purchaser for his or her lifetime against functional defects in material and applies only to the structural integrity of the Structurwood. This floor warranty covers both parts and labor.
3. **The bed wood** is warranted to the original retail purchaser for his or her lifetime against functional defects in material, and applies only to the structural integrity of the Structurwood. Parts and labor under this paragraph are covered for lifetime. This warranty excludes all other bed components i.e. bed extensions, bed frames.
4. **The steel frame** is warranted to the original retail purchaser for his or her lifetime against functional defects in material and workmanship. Both parts and labor under this paragraph are covered. This lifetime provision does not include the frame surface finish, axle beam, springs, or running gear components.
5. **The roof** of this folding trailer is warranted to the original retail purchaser for five years from the date of retail purchase against functional defects in material and workmanship. Both parts and labor under this paragraph are covered. This warranty provision does not include surface finish or damage due to the installation of non-standard equipment.
6. **Tent material:**
 - A. **The Sunbrella (302)** acrylic tent material is warranted to the original retail purchaser for five years from the original date of purchase against functional defects. During years one and two, parts, labor, and freight are covered. During year three, parts only are covered. During years four and five, parts only are warranted at 50% of the retail price.
 - B. **The Evolution 3** tent material is warranted to the original retail purchaser for three years from the date of purchase against functional defects. During year one, parts, labor, and freight are covered. During year two, parts and freight are covered. During year three, parts only are warranted at 50% of retail price; freight and labor charges are not included.

The tent material is not warranted against fading, discoloration, soiling, or problems resulting from misuse, neglect, or abuse.

The warranty of paragraphs 1 through 6B are limited to functional defects only.

During the specified times, any defective parts in a Fleetwood folding trailer will, at Fleetwood's option, be either repaired or replaced on an exchange basis with new or reconditioned parts. This Warranty does not cover the expense to take the folding trailer to the dealer for repair, nor the return expense. The consumer must pay all expenses incurred in obtaining warranty performance other than those specifically provided for in this Warranty.

The date of retail sale is established by the Warranty Registration. Replacement parts are warranted for the unexpired duration of the original warranty.

To obtain warranty performance: Consult the yellow pages of the telephone book under "Recreational Vehicle Dealers" for the name, address, and telephone number of the nearest authorized Fleetwood folding trailer dealer; or call Fleetwood Folding Trailers, Inc. at 814/445-9661. (Collect calls will not be accepted.) Call the authorized Fleetwood folding trailer dealer, report the problem and schedule an appointment. Take the trailer at the scheduled time to the dealer along with the owner's card sent to you by Fleetwood. Only authorized Fleetwood folding trailer dealers may perform warranty obligations. The authorized Fleetwood folding trailer dealer will advise when the warranty performance has been completed. All payments for warranty service and for parts will be made by Fleetwood to the dealer and not to the consumer.

GENERAL EXCEPTIONS AND EXCLUSIONS

To the extent any or all of the following exclusions or provisions of this warranty are prohibited by any federal, state, or municipal law which cannot be preempted, those exclusions or provisions shall not be applicable.

THERE ARE NO OTHER EXPRESS WARRANTIES EXCEPT AS SET OUT ABOVE AND ANY IMPLIED WARRANTIES, INCLUDING THE IMPLIED WARRANTIES OF MERCHANTABILITY AND FITNESS FOR A PARTICULAR PURPOSE, ARE LIMITED IN DURATION TO THAT OF THE EXPRESS WARRANTY. Some states do not allow limitations on how long an implied warranty lasts, so the above limitation may not apply to you.

All cosmetic and non-functional defects not noted prior to retail delivery are not covered under this warranty.

This warranty does not cover damages caused by failure to perform normal and routine maintenance as set out in the folding trailer owner's manual.

This warranty does not cover damage caused by mishandling, neglect, abuse, misuse, lightning, or corrosive atmospheres.

This warranty shall not apply if the serial number plate is removed or defaced.

Ripped or torn tents, not noted prior to retail delivery, are not covered under this warranty.

Vinyl floor covering gouges, cuts, or tears, not noted prior to retail delivery, are not covered under this warranty.

The light bulbs, fuses, tire valve cores, and other similar items are not covered by this warranty and are sold AS IS.

The tires, water heater, electric water pump, porta potti, furnace, and refrigerator in trailers so equipped are warranted by their respective manufacturers. A copy of the warranty for each of these components is provided with the folding trailer.

Trailers used for rental purposes are covered by this warranty for three (3) months from the date of purchase by the rental dealer; or if rented by an authorized Fleetwood folding trailer dealer, from the date of rental registration.

This warranty applies only to products sold at retail in the United States and Canada.

THIS WARRANTY DOES NOT COVER CONSEQUENTIAL DAMAGES OR CHARGES, such as extra expenses for transportation to and from the dealer or manufacturing plant location, loss of time, loss of pay, loss of use of the folding trailer, inconvenience, commercial loss, towing charges, bus fares, vehicle rental, incidental charges such as telephone calls or lodging bills, or other INCIDENTAL CHARGES, DAMAGES, OR EXPENSES INCLUDING DAMAGES TO PROPERTY (other than injury to person). Some states do not allow the exclusion or limitation of incidental or consequential damages, so the above limitation or exclusion may not apply to you.

This warranty gives you specific legal rights, and you may also have other rights which vary from state to state.

REPORTING SAFETY DEFECTS

If you believe that your vehicle has a defect which could cause a crash or could cause injury or death, you should immediately inform the National Highway Traffic Safety Administration (NHTSA) in addition to notifying Fleetwood Folding Trailers, Inc.

If NHTSA receives similar complaints, it may open an investigation; and if it finds that a safety defect exists in a group of vehicles, it may order a recall and remedy campaign. However, NHTSA cannot become involved in individual problems between you, your dealer, or Fleetwood Folding Trailers, Inc.

To contact NHTSA, you may either call the Auto Safety Hotline toll free at 800/424-9393 (or 366-0123 in Washington, DC area) or write to NHTSA, U.S. Department of Transportation, Washington, DC 20590. You can also obtain other information about motor vehicle safety from the Hotline.

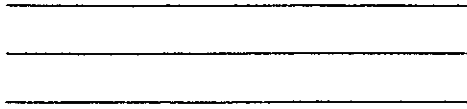

NO POSTAGE
NECESSARY
IF MAILED
IN THE
UNITED STATES



BUSINESS REPLY MAIL
FIRST CLASS PERMIT NO. 83 SOMERSET, PA 15501

POSTAGE WILL BE PAID BY ADDRESSEE

FLEETWOOD FOLDING TRAILERS, INC.
ATTN: WARRANTY SERVICE DEPT.
POST OFFICE BOX 111
SOMERSET, PA 15501-9985



CHANGE OF OWNERSHIP NOTIFICATION

MODEL INFORMATION

YR. _____ MODEL _____

SERIAL NUMBER _____

NEW OWNER INFORMATION

PURCHASE DATE _____

NAME _____

ADDRESS _____

CITY _____

STATE/PROVINCE _____ ZIP _____

PREVIOUS OWNER INFORMATION

PURCHASE DATE _____

NAME _____

ADDRESS _____

CITY _____

STATE/PROVINCE _____ ZIP _____

NOTE:

This card is to be completed and sent to Fleetwood Folding Trailers, Inc. ONLY after the original retail purchaser transfers ownership of the trailer to another party.

NOTICE TO DEALER AND CONSUMER

Because brake requirements are governed by state or provincial regulation, the requirements vary from state to state. To insure compliance with applicable regulations, we recommend you check with your Department of Motor Vehicles to determine if brakes are required on your trailer. Available through your dealer is an accessory electric brake package which can be installed on your trailer without any problem.

