

AMERICAN / PIONEER SERIES



BY FLEETWOOD®

WILLIAMSBURG
SHENANDOAH
BRANDYWINE
GRANDVIEW
SEQUOIA

CHEESAPEAKE
NEWPORT
ARCADIA
SEDONA
SENECA

1992
OWNERS
MANUAL

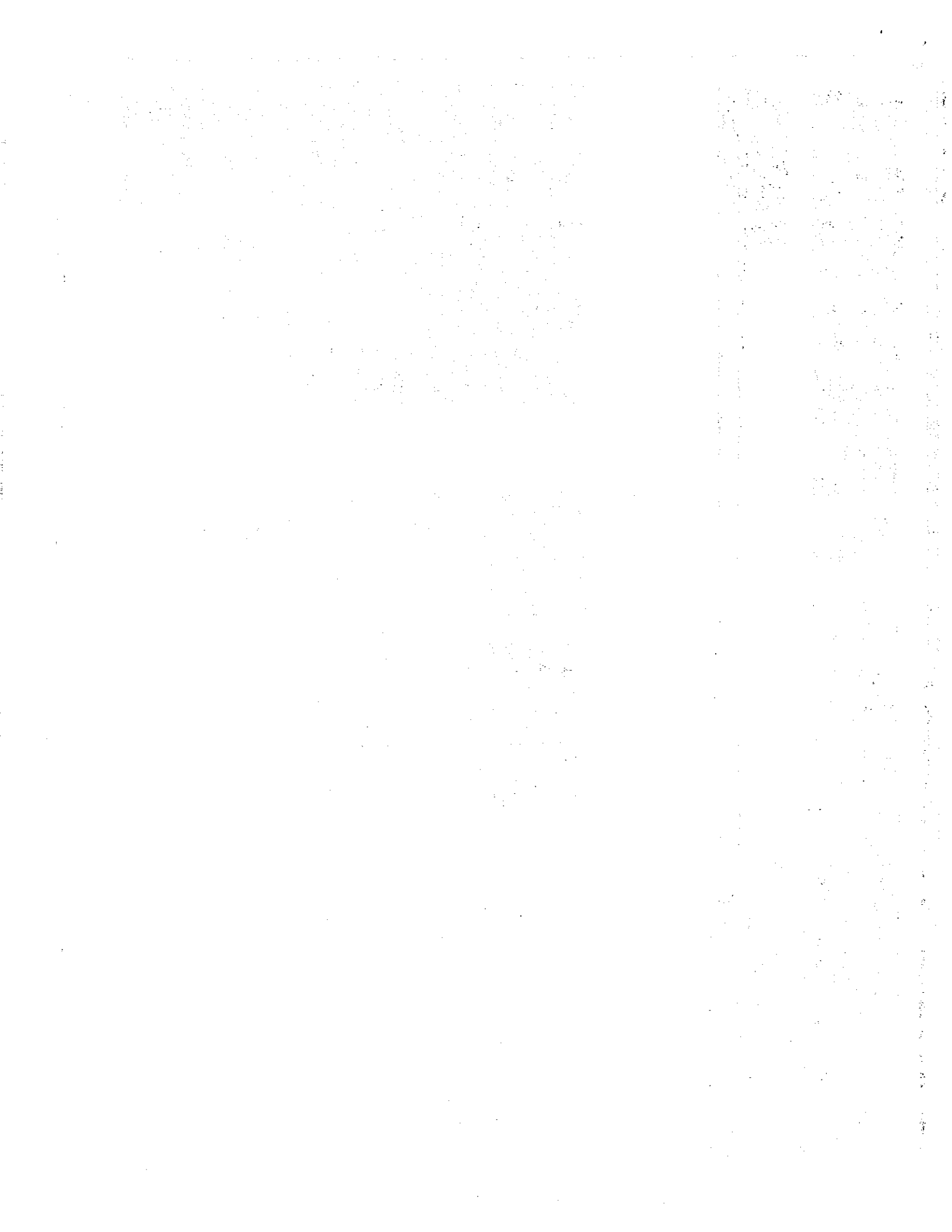

WELCOME . . .

to the wonderful world of carefree living you'll be enjoying in your new Fleetwood folding trailer. Like all Fleetwood products, your Fleetwood folding trailer by Fleetwood is the best in its class - loaded with all the quality and craftsmanship that have made Fleetwood famous.

This manual shows you in easy-to-read language how to get the most out of your folding trailer the easy way, plus tips on maintenance that will keep your folding trailer rolling through the years - virtually trouble-free. A quick look at the "Table of Contents" will show you what we mean.

So, before you take off, take a little time to read the sections on Pre-Trip Preparations, Set-Up Instructions, Take-Down Instructions, Loading, and Maintenance. It's easy reading and it really does show you how to get the most out of your folding trailer - the easy way. Have a good trip - after all, you're traveling first class in a Fleetwood folding trailer!

TABLE OF CONTENTS

INTRODUCTION	1
IMPORTANT CONSUMER INFORMATION	2
PRE-TRIP PREPARATIONS	3-4
HINTS AND TIPS	5-6
Towing	5
Tips on Picking a Campsite	6
SET-UP INSTRUCTIONS	7-21
Getting Started	7-9
Stabilizer Jacks	9-10
Bed Set-up	10-11
Tent Enclosure Set-up	11
Grandview Wardrobe Set-up	12
Sequoia Linen Closet Set-up	12-13
Screen Door Set-up	13-14
Galley Set-up	15-16
Dinette Set-up	16-18
Bed Bow Support Set-up	18-19
Galley Stove Set-up	19
Electrical and Water Hook-ups	19-21
Access to Outside Storage & Compartments	21
TAKE-DOWN INSTRUCTIONS	22-25
SYSTEMS AND SPECIAL FEATURES	26-54
Trailer L.P. Gas System	26-29
Trailer Electrical System	29-30
Water System	31-39
Tracking System	39-45
Lift System	45-46
Tent Enclosure	46-49
Miscellaneous Standard Features	49
Outside Stove Set-up	50-53
Mini-Blind	53-54
SPECIFICATIONS	55
MAINTENANCE	56-58
WARRANTY	59-61
REPORTING DEFECTS	62

INTRODUCTION

This manual contains important information regarding the safe operation and maintenance of your Fleetwood folding trailer. We urge you to read it carefully, understand all aspects of your trailer, and follow the recommendations to obtain the most trouble-free use of your recreational vehicle.

In this manual, statements preceded by the following words are of special significance:

"WARNING" means that there is a high possibility of serious personal injury to yourself and others if the warning is not complied with.

"CAUTION" means that there is the possibility of personal injury to yourself or others.

"IMPORTANT" means that there is a possibility of damage to the trailer if instructions are not followed.

"NOTE" indicates points of particular interest for more efficient and convenient operation.

We recommend that you take particular notice of these items when reading this manual.

NOTE:

The words "shall" or "must" indicate a requirement which is essential to satisfactory and safe product performance.

The words "should" or "may" indicate a recommendation or advice which is not essential and not required but which may be useful or helpful.

Please remember that when service is required, your Fleetwood folding trailer dealer knows your vehicle best. Consult him for any assistance you may require.

NOTE:

Federal law requires you to register the serial numbers of your trailer tires. For your protection, the original equipment tire serial numbers must be recorded on the warranty registration form received with your trailer. Your dealer will supply you with the necessary forms to register any additional tires (spares) you may purchase. Tire registration is not a guarantee or warranty for either the tires or the trailer.

NOTE:

Photographs and illustrations in this manual are representative of function and may or may not be specific in their depiction of actual equipment, fabrics, interior or exterior decor or design, options as installed on or in your trailer.

NOTE:

This product is designed for recreational use and short-term occupancy only. It is not designed nor intended to be used as permanent housing.

IMPORTANT CONSUMER INFORMATION

Installation and Instructions for Appliances. Operating instructions are provided for each appliance, including air conditioning appliances (other than automotive type).

This recreational vehicle is equipped with listed fuel utilization equipment and an owner's manual which contains the following information:

WARNING: L.P. gas containers shall not be placed or stored inside the vehicle. L.P. gas containers are equipped with safety devices which relieve excessive pressure by discharging gas to the atmosphere.

WARNING: IT IS NOT SAFE TO USE COOKING APPLIANCES FOR COMFORT HEATING.

Cooking appliances need fresh air for safe operation. Before operation, open a window.

This warning label has been located in the cooking area to remind you to provide an adequate supply of fresh air for combustion. Unlike homes, the amount of oxygen supply is limited due to the size of the recreational vehicle, and proper ventilation when using the cooking appliance(s) will avoid dangers of asphyxiation. It is especially important that cooking appliances not be used for comfort heating as the danger of asphyxiation is greater when the appliance is used for long periods of time.

A warning label has been located near the L.P. gas container. This label reads:

DO NOT FILL CONTAINER(S) TO MORE THAN 80 PERCENT OF CAPACITY.

Overfilling the L.P. gas container can result in uncontrolled gas flow which can cause fire or explosion. A properly filled container will contain approximately 80 percent of its volume as liquid L.P. gas.

Do not use portable fuel-burning equipment including stoves inside the recreational vehicle. The use of this equipment inside the recreational vehicle may cause fires or asphyxiation.

Do not store L.P. gas containers, gasoline, or other flammable liquids inside the vehicle because a fire or explosion may result.

IF YOU SMELL GAS:

1. Extinguish any open flames, pilot lights, and all smoking materials.
2. Do not touch electrical wires.
3. Shut off the gas supply at the tank valve(s) or gas supply connection.
4. Open doors and other ventilating openings.
5. Leave the area until odor clears.
6. Have the gas system checked and leakage source corrected before using again.

L.P. gas regulators must always be installed with the diaphragm vent facing downward. Regulators that are not in compartments have been equipped with a protective cover. Make sure that regulator vent faces downward and that cover is kept in place to minimize vent blockage which could result in excessive gas pressure causing fire or explosion.

PRE-TRIP PREPARATIONS

Before you seek out those favorite recreational campsites with your new Fleetwood folding trailer, we suggest you first make these pre-trip preparations.

Read the information in this booklet very carefully. Please note that the text for the set-up and take-down instructions does not differentiate between models. When the text does not apply to your model, continue on to the next applicable step. Set up and take down the trailer per the instructions several times to familiarize yourself completely with the procedure.

Establish a tool kit for your trailer's maintenance needs and stow it in the trunk of your tow vehicle. The following items should be included:

1. Standard slot screwdriver
2. Standard phillips screwdriver
3. Hydraulic or scissor jack (1 1/2 ton)
4. 13/16" lug wrench
5. Stabilizer jack handle (furnished - store in access door)
6. Crankshaft handle (furnished - store in access door)
7. Four wheel chocks

Final preparations should include the proper loading (See **LOADING**) and physical check of the trailer before the trip.

The trailer should be loaded with these basic rules in mind:

1. Keep your trailer as light as possible. Reducing weight will increase gas mileage.
2. Distribute the weight as evenly as possible.
3. **Be certain that a minimum of 10% of the overall trailer weight is on the ball hitch of the tow vehicle. Less than 10% will result in a negative tongue weight causing whipping or swaying while towing.**
4. Water tanks do not need filling unless primitive camping is planned; fill water tanks at campground to reduce towing weight.

Make your first trip close to home if possible. This will serve as a preparatory trip to see that everything works and what other items you will need to take.

A physical check should also be made per this checklist. Be certain that:

1. Tires are inflated to the recommended pressure as indicated on the tire sidewall.

NOTE: The two main causes for early tire wear and/or premature tire failure are.

1. Under inflation
2. Over loading (cargo)

Due to the relatively small tire sizes used on folding trailers always check the tire air pressure prior to each camping trip. Temperature changes can result in loss of tire air pressure. See Specification page for cargo capacities recommended.

2. Wheel lug nuts/bolts are properly torqued: 8" wheels, 70-80 lbs; 10" wheels, 80-90 lbs. Check torque before first trip. Retorque after first 25 miles. Retorque after first 75 miles. Retorque periodically thereafter and before each trip.
3. The tongue coupler is securely fastened to the ball hitch with safety pin in place.
4. The safety chains are attached (chains must crisscross).
5. The electrical pigtail is connected.
6. All lights on the trailer are functioning properly.

7. The L.P. gas bottle valve is closed.
8. The cooler and other items are securely held in place.

We hope you read and follow these instructions and helpful hints very closely. If you do, you will receive the maximum benefit from your Fleetwood folding trailer.

HINTS AND TIPS

A. Hitch

When mounting a hitch on your tow vehicle, a minimum distance of 4" between hitch ball and the tow vehicles bumper should be maintained. (See Figure 1)

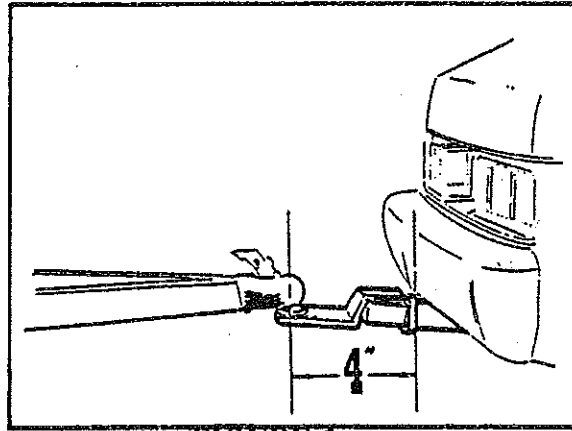

FIGURE 1

Any hitch with the coupler ball mounted closer than 4" will allow the frame to make contact with the bumper resulting in "A Frame" damage. (This is most frequently found to be true on step bumper applications.)

B. Towing

Even if you've towed before, you'll want to get the feel of maneuvering any new outfit, so practice starts, stops, parking, braking, and turning. When driving around town, always check the traffic clearance before pulling out from the curb or shoulder into the main traffic flow. For turns, pull past your turn or intersection sufficiently before turning so as not to run into the curb or obstructions. The longer your trailer, the wider you must swing for clearance. Most new owners are surprised at how well Fleetwood folding trailers track and how little additional maneuvering space is required, but don't let this cause you to forget it's behind you.

During parking or backing, remember that the rear of the folding trailer moves opposite to the rear of the towing vehicle. Start by simply placing your hand on the bottom of the steering wheel, then moving your hand left (wheel turning right) will move the trailer to the left and vice versa.

On the road, maintain a safe driving distance from other vehicles. A safe driving distance is the total length of your towing vehicle and folding trailer combined for each ten miles per hour of speed.

When approaching a downhill grade, downshift, letting the engine compression act as a brake. Should you need added braking, apply your brakes as required.

When approaching an uphill grade, the answer is the same - downshift. This keeps the engine from lugging down which may overheat from laboring in a higher gear.

Your towing equipment, its adjustments and how you load the trailer will have a great effect on trailer towing stability and handling.

- * Use a tow vehicle that is large enough for your trailer and has the needed power and appropriate towing equipment package.

Hitching up your trailer will become routine with experience. Make it a habit to examine all hitch components before hitching the trailer. If you have a conventional ball hitch, check for cracked or bent parts, cracked welds, and deformed or stripped bolts. Be sure the hitch ball is tight and well lubricated. Inspect the safety chains. If you find defects in any hitch component, correct it before towing the trailer.

When weighing your trailer always use a platform scale such as those used by trucking companies or highway weigh scales.

1. **Weigh the trailer by itself.** After driving the tow vehicle and trailer onto the scale, disconnect the trailer from the tow vehicle and move the tow vehicle off the scale. The measured weight of the loaded trailer must not exceed the GVWR of the trailer. Cargo or equipment items must be removed until the GVWR is not exceeded.
2. **Find the tongue weight.** When the total trailer weight is under the rated GVWR, you next determine the trailer tongue/coupler weight.

For conventional trailers: Move the trailer until the tongue is off the scales. Relevel the trailer by adjusting the height of the tongue jack. Read the trailer weight on the axles alone. Subtract weight on the axle from the total weight. This weight difference will be the approximate tongue weight.

C. Tips on Picking a Campsite

DO . . .

Find a level spot that gets some breeze or wind. The breeze will improve ventilation in your trailer and keep bugs away.

Try to find a site with trees that will provide shade in the afternoon when the sun can get unpleasantly hot.

WARNING:

Camp on high ground, not in river or creek beds where flash floods can prove to be a danger.

Locate the trailer reasonably near water facilities, toilets, and electrical hookups.

DON'T . . .

Pick a site near a busy road or boat dock. Late-arriving campers and early-rising fishermen can cause you to lose sleep.

Pick a site near standing water or swampy area. These are obvious breeding grounds for mosquitoes.

Park near any tree that has large dead branches that may blow down on your trailer.

SET-UP INSTRUCTIONS

GETTING STARTED

Prior to the initial camping trip, familiarize yourself completely with the operation, care and construction of your new Fleetwood folding trailer. Upon your first camp, we suggest that you set up your Fleetwood folding trailer slowly and per the set-up instructions to prevent unintentional damage to the equipment.

1. Select a level campsite, preferably not on soft or sandy terrain.
2. Pull or back the folding trailer to desired position for campsite.
3. Disconnect electrical pigtail and safety chain, and release the coupler release handle. See Figure 1.
4. Pull the lock pin (located on the tongue jack) and let the tongue jack swing down into position. Allow the lock pin to lock the tongue jack in place in the top left hole in the brackets. See Figure 2.

CAUTION:

Failure to engage the tongue jack lock pin could result in the trailer tongue falling resulting in injury to yourself or others.

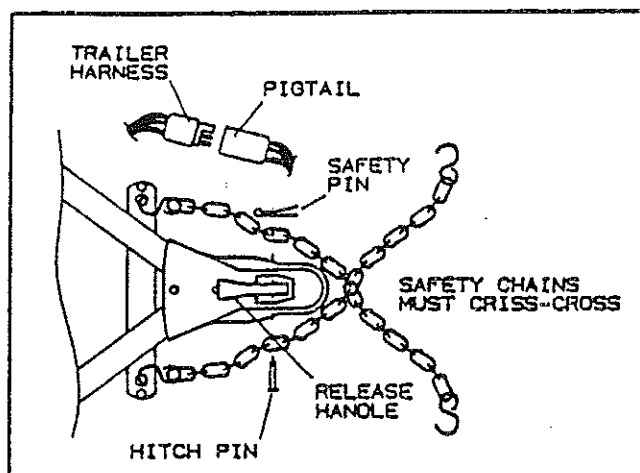

FIGURE 1

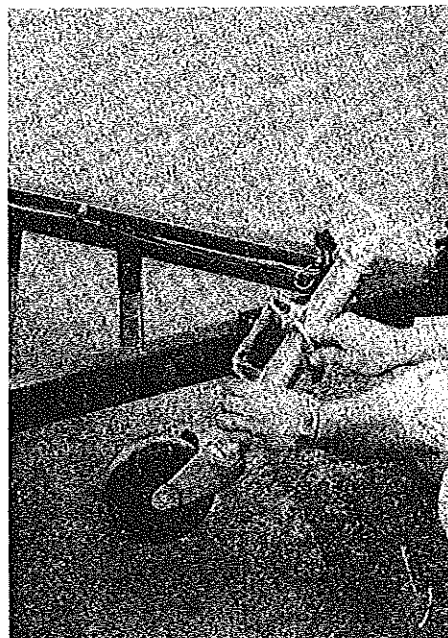

FIGURE 2

5. Pull the handle of the tongue jack up and rotate the handle in a clockwise motion to lift the trailer tongue up and off the ball hitch.
6. To prevent interference during the set up of the trailer, drive the vehicle away from the trailer or move the trailer to the desired location for the campsite.
7. Adjust the tongue jack height so that the trailer is level horizontally.
8. Unlatch the four "top" latches. See Figure 3.

9. From the right side of the trailer, insert the key into the lock (located on the access door) and turn 90° clockwise. The pushbutton and handle will pop out. Rotate the handle 90° clockwise to open the access door. Pull out and down on the access door to provide an entrance.

IMPORTANT:

Before lowering the access door, insure that the area directly beneath the access door is free from obstacles to prevent damage to the exterior finish of the access door.

10. Remove the crank handle from the recommended storage location in the access door step and attach it to the crankshaft located on the upper curbside area of the front body panel.

11a. On Americana series trailers, open the crankshaft cover door then turn the posi-action control handle clockwise to the "open" position (see Figure 4). Make certain the safety latch mechanism rests on the center crankshaft and rotate the crank handle in a clockwise motion to raise the top. See Figures 4, 5, and 6.

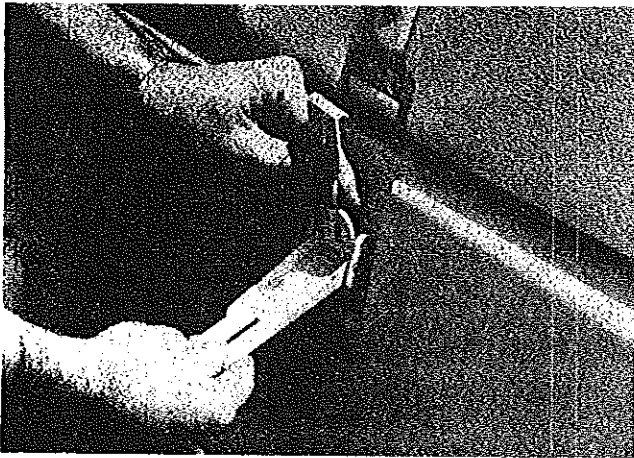

FIGURE 3

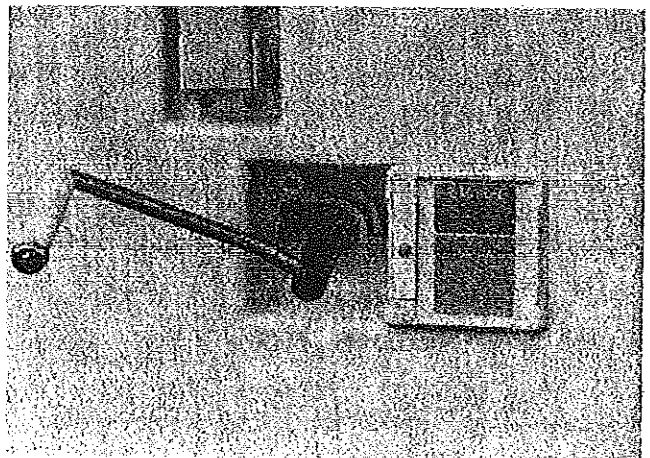

FIGURE 4

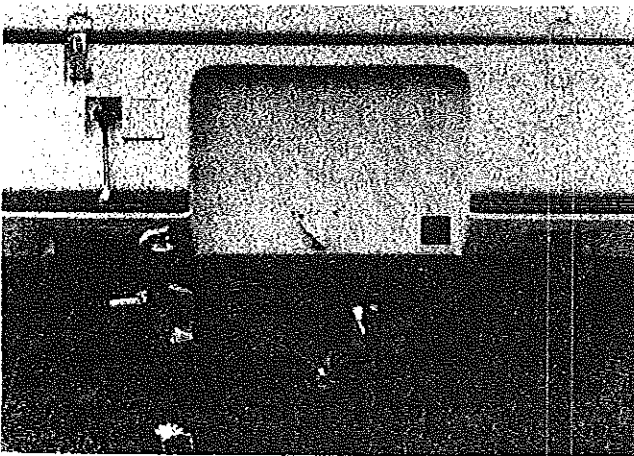

FIGURE 5

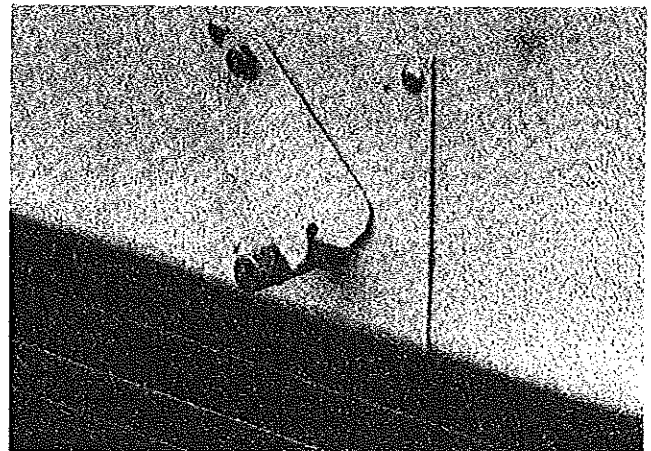

FIGURE 6

CAUTION:

The safety latch must be engaged to prevent accidental top assembly descent in the event of ratchet or chain failure.

11b. On Pioneer series trailers, it will be necessary to engage the crankshaft hook to hold the top up. Engage the crankshaft hook prior to releasing the crank handle. The crankshaft hook is located adjacent

to the lower center crankshaft. See Figure 7.

CAUTION:

Keep a constant inward pressure on the crank handle when cranking the top up to prevent the crank handle from backing off the crankshaft. During the lifting of the top **DO NOT RELEASE THE CRANK HANDLE** without engaging the crankshaft hook located adjacent to the lower center crankshaft on Pioneer series trailers or the posi-action control and safety latch on the Americana series trailers. Bodily injury could result if the handle is released and spins freely when raising or lowering the top. Failure to engage these safety mechanisms could result in the uncontrolled descent of the top assembly.

12. Raise the top until it is fully extended or the tent fabric becomes reasonably taut, whichever occurs first.

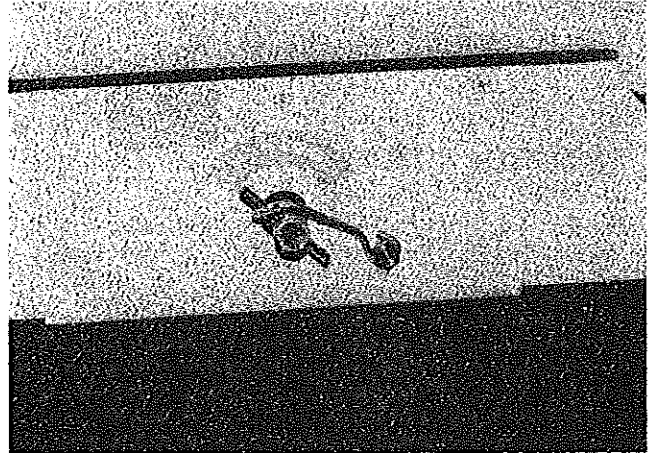

FIGURE 7

IMPORTANT:

DO NOT crank the top to an extreme tautness, otherwise the cables can be stretched or broken.

STABILIZER JACKS

CAUTION:

Do not lower the stabilizer jacks prior to raising the trailer top as this can place an undue stress on the trailer frame and lift system resulting in premature wear. Do not use the stabilizer jacks to take the weight of the trailer off of the tires except when changing a flat tire. The jacks are intended **ONLY TO "STABILIZE."**

WARNING:

Do not lie under trailer when putting stabilizers down or up. Should the trailer fall, serious bodily injury could result.

NOTE:

When the trailer has been over rough terrain and the stabilizer jacks have collected road tar, mud, or brush, it may be necessary to dislodge the foreign matter from the stabilizer jacks before lowering into position.

13. All Americana and Pioneer series models (with the exception of the Sedona model) are equipped with four stabilizer jacks. One jack is located in each corner of the trailer. The Sedona model is equipped with two stabilizer jacks, one in each rear corner.

To release the stabilizer jacks from the locked travel position, reach under the corner of the trailer, firmly grasp the jack and push it toward the center of the trailer (approximately 1/2"), and swing down to lock the jack in the lowered position. See Figure 8.

14. Each stabilizer jack has an inner leg which must be extended to the ground. Because of certain

terrain conditions, it may be advisable to locate flat blocks of wood or flat rocks under the base plates of the stabilizer jacks.

15. Remove the stabilizer jack handle from the recommended storage location within the access door. Making sure the handle is inserted through the rear hole, apply downward pressure to extend the inner legs of the stabilizer jacks to stabilize the trailer. See Figure 9. Remove jack handle and stow.

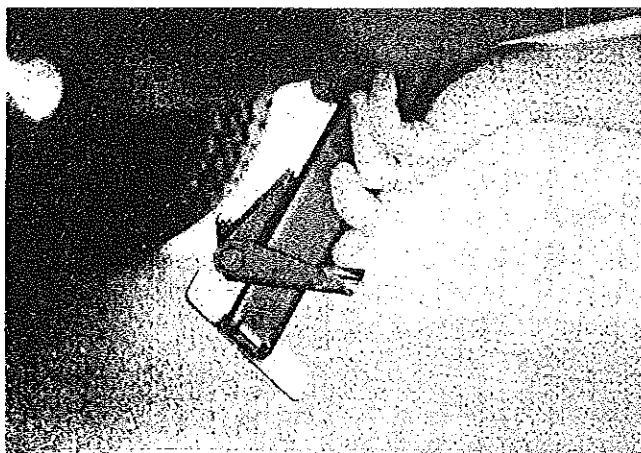

FIGURE 8

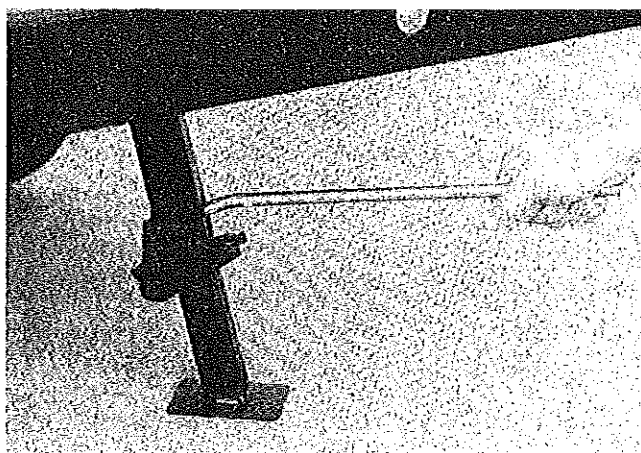

FIGURE 9

BED SET-UP

16. Standing right of center at the tongue end of the trailer, place hands (approximately 1 1/2 feet apart) on the bed frame and pull until the bed hits the stops. See Figure 10.

IMPORTANT:

This movement must be done slowly and evenly to prevent inadvertent jamming or wedging of the bed on the sliding tracks.

IMPORTANT:

DO NOT put any weight on the beds while they are extended without first attaching the bed supports as damage to the bed rails may result.

17. Kneel down beneath the side of the fully extended bed. Pull down and swivel the bed support tubes from their travel positions. Lift the bed slightly while placing the free end of the bed support tube over the support peg. Perform same procedure for the rear bed. See Figure 11.

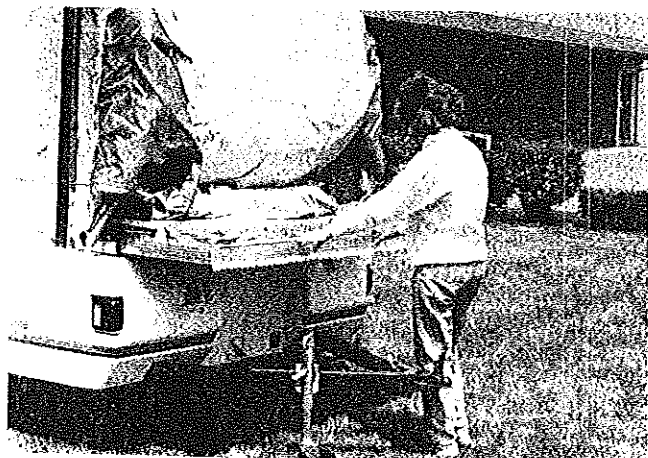

FIGURE 10

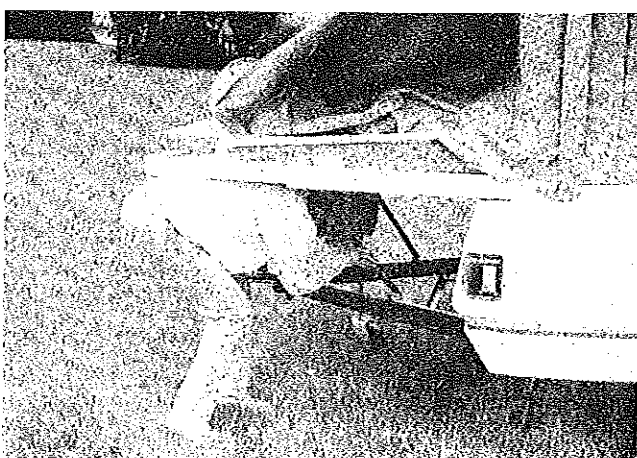

FIGURE 11

NOTE:

Queen size beds have four supports.

IMPORTANT:

Insure bed support post is fully engaged on the peg, otherwise any weight placed on the bed will cause damage to the bed's slide tracks. Bed supports are designed to swivel into travel or setup position; do not force the bed supports when setting up or taking down.

TENT ENCLOSURE SET-UP

18. With both beds fully extended and supported, grasp the bottom edge of either the front or rear tent enclosure with hands approximately 2 1/2 feet apart. Gently pull until the tent fabric is pulled out toward the end of the wing beds. See Figure 12. Standing at either side of the wing bed, reach in underneath the tent fabric and grasp the side of the canvas bow and rotate toward the end of the bed. See Figure 13.

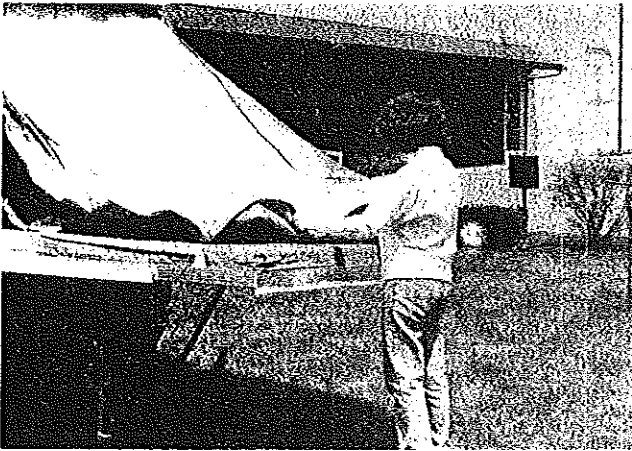

FIGURE 12

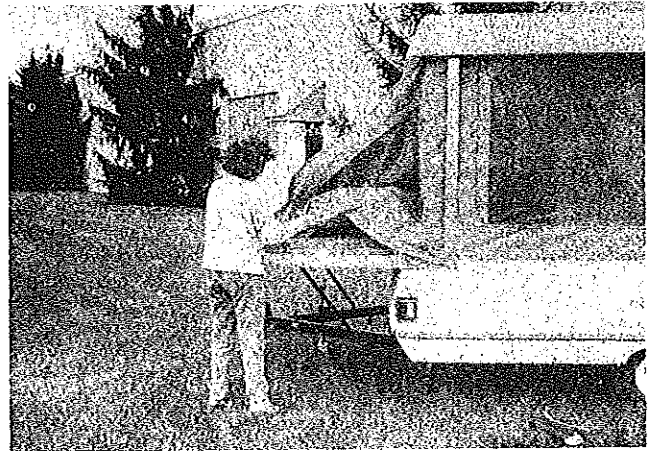

FIGURE 13

19. Pull the tent at the bottom over the bed edge and attach the exposed stretch cords to the nearest hooks on the underside of the bed. See Figure 14. Repeat for other bed end. Be certain to slide the stiffened tent fabric sections under the bed corners between the bed bottom and body rail top. These stiffened corners will prevent the entrance of insects drawn by the folding trailer interior lighting.

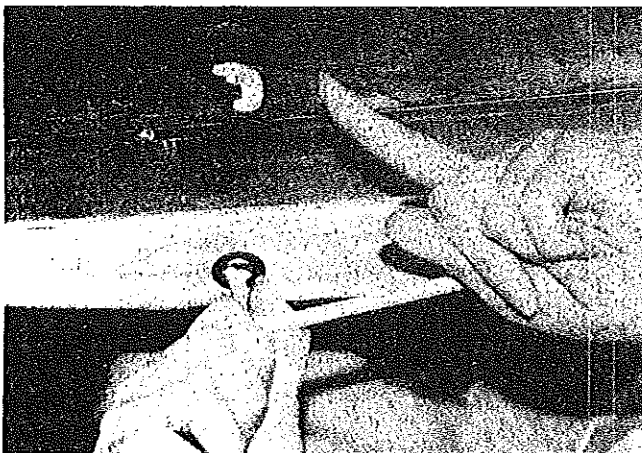

FIGURE 14

On Americana and Pioneer model trailers storage pouches have been designed into the lower section of the side tent enclosure panels.

CAUTION:

Do not store sharp objects within the storage pouches or irreversible damage could occur to the tenting material.

GRANDVIEW WARDROBE SET-UP

20. Grasping the wardrobe with two hands, lift and hold in the vertical position with one hand. See Figure 15.

21. Using your free hand, turn the locking latches 90° to secure the cabinet in place. See Figure 16.

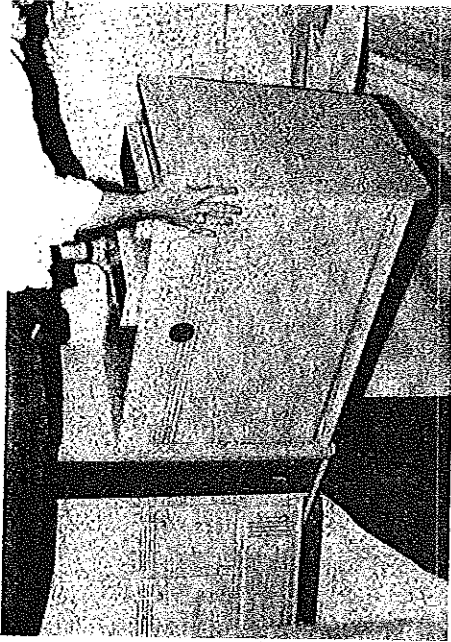

FIGURE 15

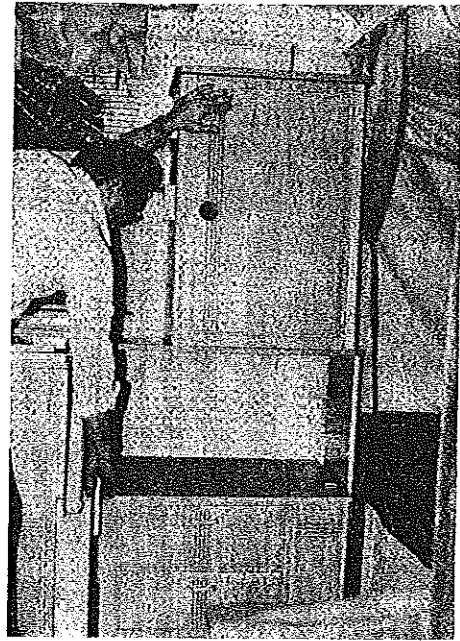

FIGURE 16

SEQUOIA LINEN CLOSET SET UP

22. Grasp the closet and raise the assembly until vertical. (See Figure 17)

23. While holding the closet in the vertical position, open the wooden rest from its storage position against the interior trailer wall and slide it under the closet. (See Figure 18)

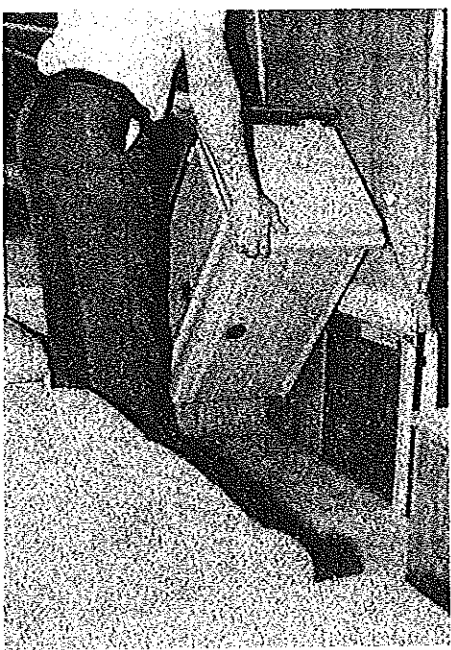

FIGURE 17

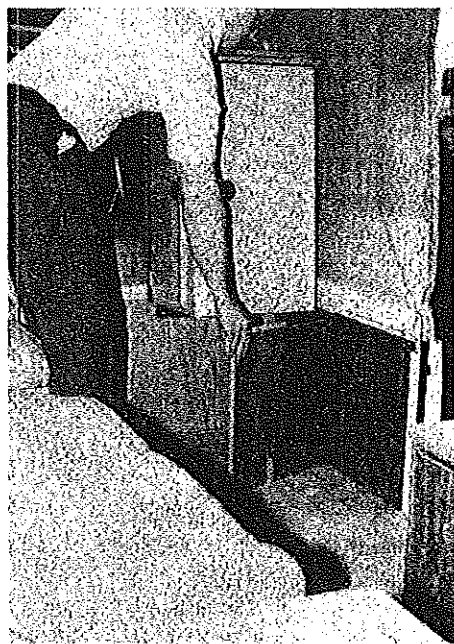

FIGURE 18

SCREEN DOOR SET-UP

24. Unfasten the two screen door web retaining straps. This will allow the screen door to hang by its glide cables.
25. Standing at the door opening, pull down on the spring-loaded pin clip retaining the door frame and swivel clear of the engagement hole. See Figure 19. Standing at the door threshold, reach up and grasp the bottom of the screen door with both hands. Raise and push the door toward the far side of the trailer to release it from its retaining brackets. See Figure 20.
26. Hold screen door up from the floor and move it toward the door opening. See Figure 20.

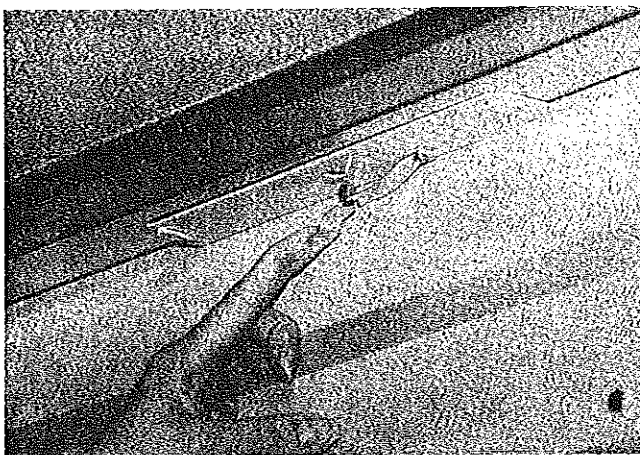

FIGURE 19



FIGURE 20

27. Step outside and grasp the door frame with both hands, one on either side, lower screen door into door threshold at base of doorway. See Figure 21. Unlock screen door latch and step inside.

28. On Americana series, rotate the hinged top door plate to vertical position and lock in place with the two screen door sash locks. (Pioneer series has rigid plate.) See Figure 22.



FIGURE 21

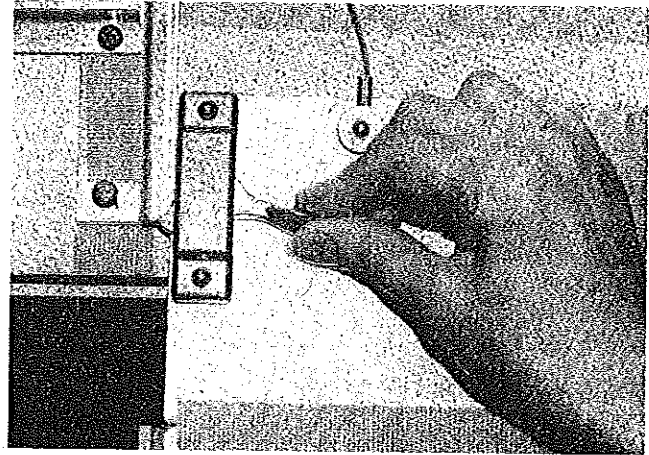

FIGURE 22

29. Step outside trailer and starting at the base of the tent material, press the tent weatherseal on either side of the doorframe into the weatherseal groove on the doorframe. See Figure 23. Fasten tent retainer patches to the doorframe and body rail with the mating velcro. See Figure 24.

NOTE:

On very tight tents, set-up is much easier if the screen door weatherseals are installed prior to attaching the tent at bedends. Rest each bed tent on top of the beds, install the weatherseals, and then pull the tent over the bed edges.



FIGURE 23



FIGURE 24

GALLEY SET-UP

Pioneer Series

30. Grasp the towel rack on the upper galley assembly. Lift up and rotate 180° toward the outside of the trailer. See Figure 25.

NOTE:

Be certain to undo the web strap securing the water and gas hoses to the lower galley top prior to galley set up. Also check water and gas hoses to be sure they are not pinched between galleys.

IMPORTANT:

Be sure the upper galley is securely latched to the lower cabinet top retaining latch. A click can be heard as the retaining latch engages. See Figure 26.

NOTE:

Retaining latch is not applicable on Arcadia models.

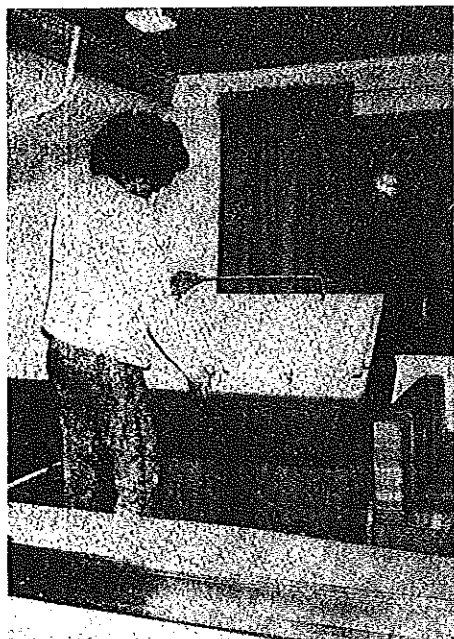

FIGURE 25

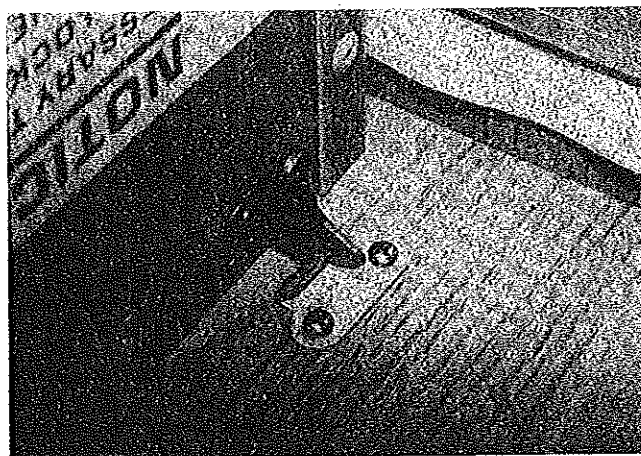

FIGURE 26

Americana Series

Grasp the center of the tubular bar of the swing-level galley and raise until the bottom of the upper galley rests securely on the top of the lower galley compartment. See Figure 27.

CAUTION:

Be certain to grasp the swing-level galley tubular bar in the position indicated by the decal (center). Failure to do so could lead to inadvertent pinching of the hand as galley rotates.

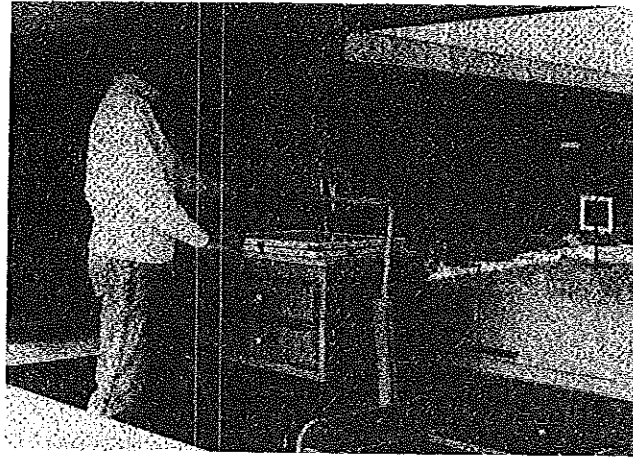

FIGURE 27

CAUTION:

Slide the safety ties attached to the bottom of the drapes into the track behind galley. These ties eliminate the possibility of the drapes coming in contact with the stove.

DINETTE SET-UP

31a. On models with a rear dinette, lift the backrest off the dinette table and slide the seat cushion inboard. Set the backrest in place against the side wall. Slide the seat cushion in place, making sure that the plastic stops are wedged firmly against the interior of the metal seat frame. (See Figure 28.)

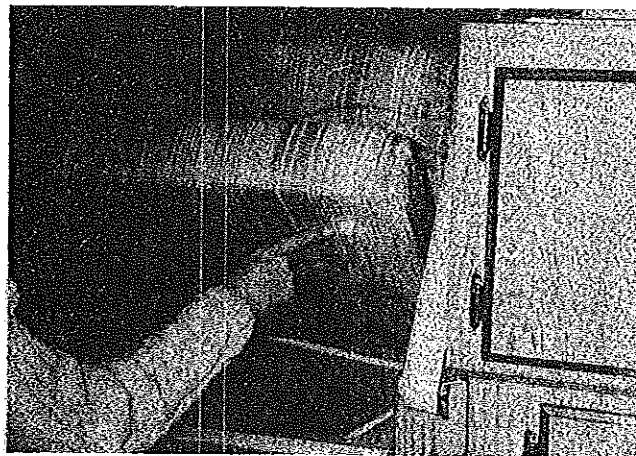

FIGURE 28

31b. On models with a side dinette, lift the backrest off of the dinette table and slide each seat cushion inboard; that is, the rear seat cushion toward the front of the trailer and the front cushion toward the rear. Set one backrest in place against the front wall of the trailer and the other against the galley side. Slide the seat cushion in place making sure that the plastic stops are wedged firmly against the interior of the metal seat frame.

31c. On Seneca model with a split dinette, lift the front backrest support into position. See Figure 29. Slide backrest cushion in place by inserting the upright support into cushion cover pocket. See Figure 30.

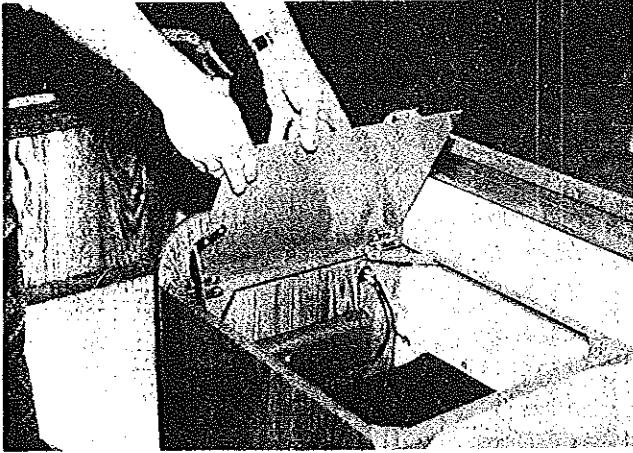

FIGURE 29

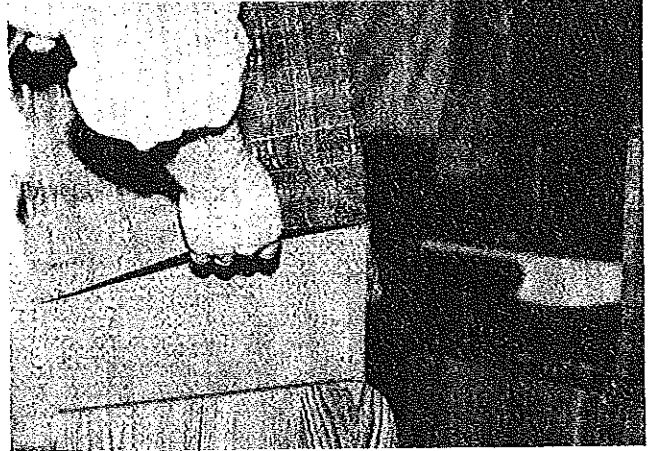

FIGURE 30

NOTE:

To lift dinette seat, be certain to push the seat cushion firmly toward the backrest wall before lifting in order to prevent inadvertent damage to the plastic stops. See Figure 28.

NOTE:

Where applicable a flip-up seat retainer is provided to hold the cushions upright to permit seat storage access.

32a. Extend the table legs completely so that both leg supports lock into position. Set table upright and check to insure it is stable. (See Figure 31.)

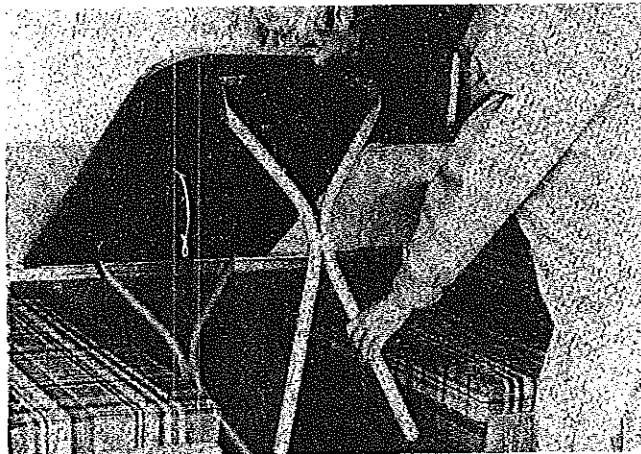

FIGURE 31

32b. (Seneca model pedestal table) locate the pedestal post underneath the table top and remove from it's storage location. (See Figure 32) Place post into the floor mounted base and position table top on post. (See Figure 33)

CAUTION:

The table top could be damaged by exposure to rain or extended periods of sunlight.

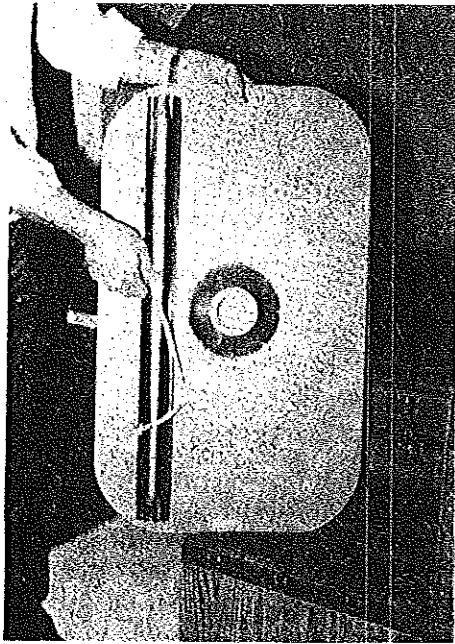

FIGURE 32



FIGURE 33

BED BOW SUPPORT SET-UP

33. Adjust bed bow support as necessary to make the tent enclosure over the bed taut. This is done by pressing the release button on the pole and extending the rod to the next adjustable hole. See Figure 34

34. To completely support the tent enclosure over the bed (front and rear), attach the bed bow support by inserting the straight end into the bed bow. Insert the opposite end of the bed bow support into the metal roof retainer. (See Figure 35 and 36.)

NOTE: These may be stored in a preadjusted state under each mattress.

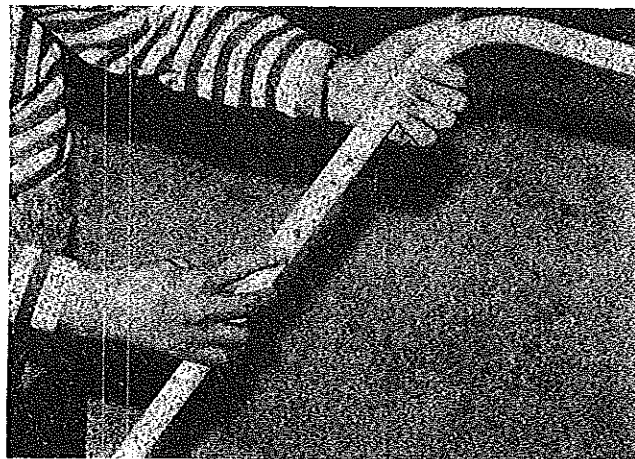

FIGURE 34

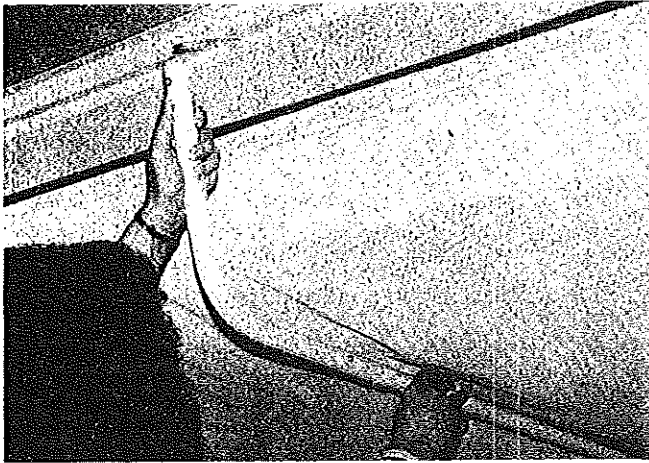

FIGURE 35

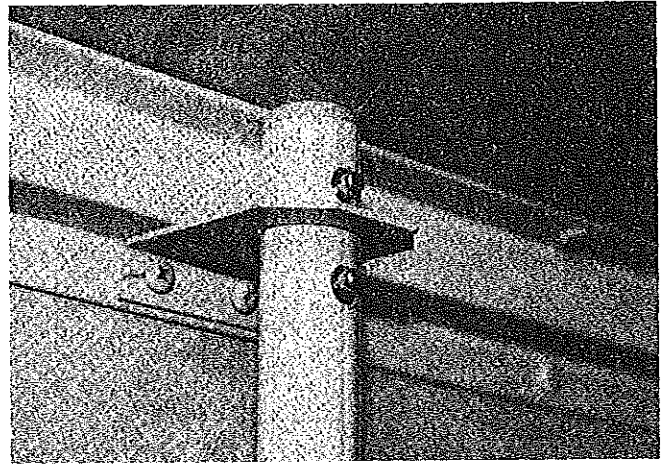

FIGURE 36

GALLEY STOVE SET-UP

35. Unfasten the catch securing the stove cover. Raise the stove cover into position. Rotate the splash guard toward side of stove and fasten to side of cooktop with twist latch. See Figure 37.

IMPORTANT:

Do not place hot cooking utensils on cabinet tops or table top. Damage to surface could occur.

36. Check to insure all burners on the stove unit are turned off. Open the valve on the LP gas bottle all the way by rotating handle in a counterclockwise direction.

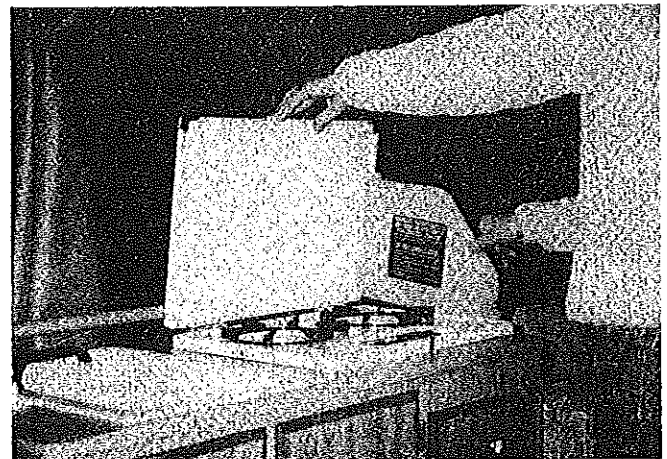

FIGURE 37

WARNING:

When trailer has been over rough terrain, test gas piping and appliances with soapy water for leakage. **DO NOT** test with a lighted match. **DO NOT** tamper with the gas bottle regulator; it is factory adjusted. Failure to adhere to this warning could lead to an undetected gas leak resulting in fire and/or explosion.

37. Turn on one LP burner on the stove unit and hold a lighted match near the LP burner.

NOTE:

Initially, it will take 20-40 seconds for the gas to flow from the bottle to the burner after which the LP burner will ignite.

ELECTRICAL AND WATER HOOK-UPS

38a. When the campsite provides a pressurized water system: On Americana series, insert the key in

the utility port door and open. Remove the protective cap from the external pressure water connector. Attach a non-toxic garden hose (not furnished) between the external trailer connection and the campsite-furnished faucet.

NOTE:

The locked utility port door is standard only on Americana series trailers. Pioneer series trailers do not have a utility port enclosure door. See Figure 38.

On Americana models the electrical cord storage location is contained within the outside storage access area. See Figure 39.

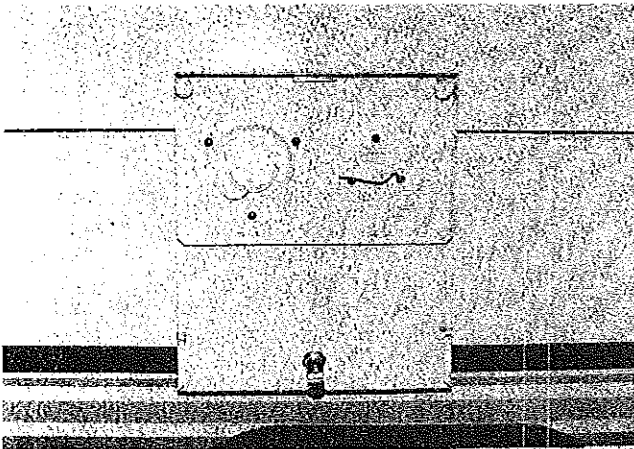

FIGURE 38

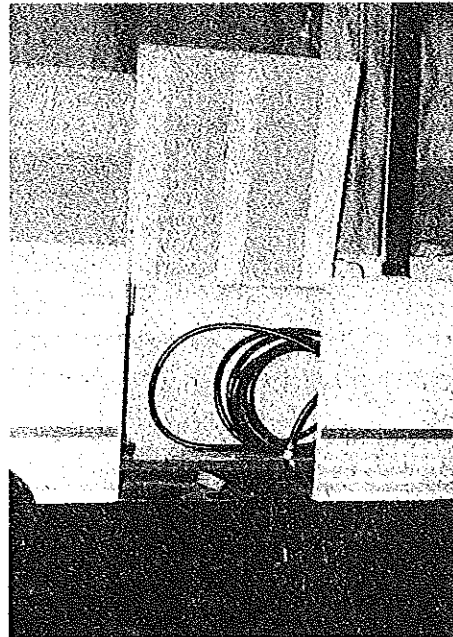

FIGURE 39

38b. If the campsite does not provide a pressurized water system, it will be necessary to use the trailer internal water system. In order to fill the storage tank of Americana series trailers, open the fill spout enclosed within the utility port door and fill the tank using a non-toxic hose or appropriate container. On Pioneer series trailers, the five-gallon water storage bottles can be removed from inside the trailer and filled at a suitable water filling station.

39. Connect the water system drain hose (not supplied) to the trailer outside fitting (as identified on the trailer by the "DRAIN" decal) to the park sanitary system or suitable waste container.

CAUTION:

Do not interchange waste system hose and fresh water hose as contamination to the water supply could result.

40. When the campsite provides an electrical system: on Pioneer series, lift up the cable hatch cover, grasp the self-storing power cord plug and pull it out. Plug the power cord into the campsite-provided outlet. From inside the trailer at the power supply center, set the converter switch to the "CONVERT" position.

WARNING:

The electrical system is rated for a maximum 15 amperes normal household-type current. Be sure not to exceed this rating. Excessive amperage draw could cause electrical system problems. Be sure any outlet the trailer is plugged into is grounded and has the correct polarity.

CONVERTER:

The converter changes the 115 volt park supply to 12 VDC for operation of the interior 12 volt lights and certain 12 volt appliances (i.e., furnace, factory-installed refrigerator). The receptacles inside the trailer carry the 115 volt current for operation of 115 volt appliances and the like. Set the converter switch in the "convert" position for this type operation.

When the converter is set to "BATT," the interior electrical lights must be serviced by an external 12 volt battery for the electrical supply. This external battery could be the tow vehicle battery or a tongue-mounted auxiliary battery.

NOTE:

The converter contained within the trailer **WILL NOT** recharge a tongue-mounted battery.

WARNING:

Do not use or store a battery inside the trailer. Battery acid leakage or explosion could cause bodily injury or death.

On the tongue of the trailer are two 12 volt DC wiring harness connectors. One connector is a six-prong connector which connects to the tow vehicle for the operation of running lights, brake lights, and so forth. The other two-prong connector is for the operation of the 12 volt interior lighting system and optional furnace. In order to use the two-prong receptacle, it is necessary to purchase the 12 volt auto extension cord from your dealer. This cord may be plugged into the tow vehicle cigarette lighter to provide 12 volt power to the interior of your folding trailer.

IMPORTANT:

Never allow the 12 volt, two-prong receptacle to be plugged in while the trailer is in the closed position. Excessive heat build up in the interior lights could cause damage to the tent material of your folding trailer.

ACCESS TO OUTSIDE STORAGE & COMPARTMENTS

41. Americana series trailers not equipped with a built-in refrigerator have as standard equipment an outside access storage compartment. In order to gain entrance to the compartment from the outside of the trailer, simply insert the trailer key into the lock on the storage compartment, turn 90° clockwise, and raise the outside storage panel. Retain in position with the panel support provided. When closing the panel, be certain the lock is fully engaged by turning the key 90° counterclockwise. Access to this storage compartment can be gained with the trailer in either the closed or open position.

TAKE-DOWN INSTRUCTIONS

1. From inside the trailer, flip the circuit breaker and converter switch to the "OFF" position.
2. Disconnect the power cord from the campsite outlet and return the cord and plug to its storage location. Close cable hatch on Pioneer series and access door on Americana series..
3. Disconnect the non-toxic garden hose from the campsite-provided faucet and the external trailer connection. Stow the hose.
4. Attach the protective cap onto the external city water connector to prevent foreign matter from entering the internal water system. On Americana series, close and lock the utility port door.
5. Close the valve on the L.P. gas bottle all the way by rotating the handle in a clockwise direction until the valve seats.

CAUTION:

Do not attempt to operate any propane appliance while the trailer is in tow.

6. From inside the trailer, open and light one L.P. burner and allow to burn until flame extinguishes. This will safely and effectively bleed the system.
7. Turn L.P. burners to off. Pull the stove cover down and secure for travel with the catch. See Figure 37.
8. Drain all water in the sink and tighten basket strainer.
9. Disconnect the waste system hose from the external trailer connection. Thoroughly rinse the hose and store. Replace drain cap.
10. Close all drapes completely and remove safety ties from curtain track located behind the galley.

NOTE:

For quicker camp set-ups at a later time, it may be desirable to leave the drapes up throughout the trailer. The drapes may wrinkle slightly, but the wrinkles will fall out during the next camp set-up. If drapes are left hanging, be sure to unhook drapery ties.

11. Detach both front and rear bed bow supports from the roof retainer and from the bed bow. Lay the bed bow supports under each mattress. See Figure 35.

NOTE:

Remove any accessories that are mounted to the top assembly (i.e., wardrobe rack, vanity board, or overhead cabinet) if the trailer is so equipped.

12. Lift the dinette table up on end. Apply inward pressure to the leg support locks and lower and secure legs by attaching the elastic cord over both dinette legs.

12a Remove table top from pedestal post. Remove post from floor mounted base and locate in storage position under table top. (See Figure 33)

13. Secure the dinette table by locating it on the rests between the bench seats. See Figure 32.

14. Remove the backrests from their positions. Slide the seat cushions outboard and place the backrests, cushion side down, on the stored dinette table. See Figure 28.

15. Step outside the trailer. Begin at the top of the doorframe and carefully pull the tent weatherseal on either side of the doorframe from the weatherseal groove attached to the doorframe. Unfasten tent velcro patches from door frame and body rail. See Figures 23 and 24

16. Step inside the trailer and release the top door retainers. Lock the screen door latch. Grasping the doorframe with both hands, one on each side, lift up and remove from the door threshold and allow the door to tip inward. See Figures 21 and 22.

17. Step outside the trailer and grasp the bottom of the doorframe, lift up and push the top of the door toward the far side of the trailer. Place the bottom of the door onto the pins on the retaining bracket and lock spring-loaded pin clip into base of door frame (see Figure 19) and snap web retaining straps. Be certain door is securely engaged on all three pins.

18. On Grandview models lower the wardrobe in the following manner: Holding the wardrobe in the upright position, turn the locking latches 90° to release cabinet. Using both hands lower cabinet to floor.

18a On Sequoia models, lower linen closet in the following manner: Grasp the closet and lift slightly. Fold the wood brace against the interior trailer wall. Lower closet to the trailer floor.

19. On Pioneer series trailers, grasp the towel bar of the galley unit, reach behind the galley at the left rear corner and release the retaining latch by depressing the lock while raising and rotating the galley unit 180° to the inside of the trailer and lower gently to the floor. See Figure 25.

For the swing-level galley, grasp the center of the tubular bar at designated location, rotate and lower to trailer floor. See Figure 27.

NOTE:

Be certain floor is clean and free of any grit or sand to prevent damage to the surface of the telescoping hole cover. (Americana models)

20. Step to the tongue end of the trailer; release the exposed stretch cords from the hooks located under the extended bed. **Pull the stiffened corners of the tent out from between the bed and body rail.**

21. Pull the tent up and over the bed edge. Grasp the bed bow and push toward the center of the trailer until it lays flat on the bed. Insure that the tent material is evenly distributed over the bed to facilitate closing of the top assembly.

22. Kneel down beneath the right side of the extended bed. With one hand, raise the bed gently and with the other hand remove the bed support tube from over the support peg. Swivel each support tube up and lock into the travel position. See Figure 11.

23. Repeat step 22 for the left side.

24. Insure the tent fabric is up away from the bed edge. Standing at the center, place hands on the bed frame and push until the bed hits the stops. This movement must be done slowly and evenly to prevent inadvertent jamming or wedging of the bed on the sliding tracks. See Figure 10.

25. Perform steps 20 through 24 for the remaining extended bed.

26. Set up the trailer tongue jack if it was previously retracted to the towing position.

CAUTION:

Be sure the tongue jack is supporting the trailer tongue and is locked in position to prevent sudden collapse of trailer tongue.

IMPORTANT:

Do not lower top unless the stabilizers are released.

27. Remove the stabilizer jack handle from the storage location.
28. Press on the quick-release lever of the stabilizer jack with the jack handle and push downward slowly. This releases the stabilizer jack and the corner of the trailer will drop somewhat.

WARNING:

Stand clear of the trailer when pressing on the quick-release lever for the trailer will drop when it is released. Do not lie under the trailer when releasing or lowering the stabilizers. Bodily injury could result due to the quick drop of the trailer if these warnings are not followed.

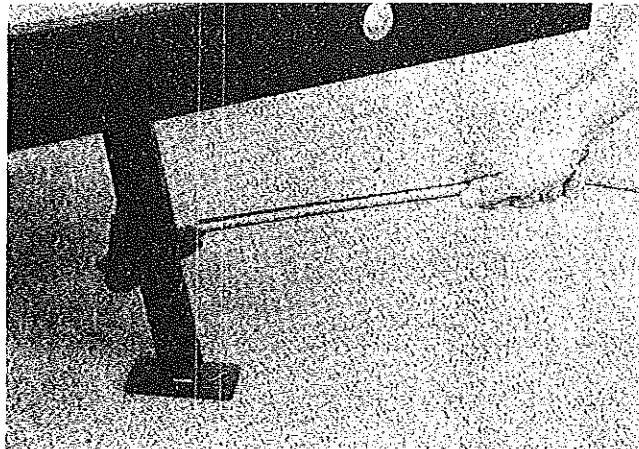

FIGURE 40

29. With the quick-release lever in the disengaged position, slide the inner stabilizer leg up into the stabilizer jack until it locks in position.
30. Grasp the stabilizer jack, pull down and push up toward the center of the trailer into its horizontal travel position. Jiggle and pull back the stabilizer jack to insure it is up and locked into position.
31. Perform steps 28, 29, and 30 for the other three stabilizer jacks and then stow stabilizer jack handle.
32. Remove the crank handle from storage location and attach to the crankshaft.
33. On Pioneer models, rotate the crank handle clockwise slightly to relieve the tension on the crankshaft hook. Disengage the crankshaft hook. On Americana models, turn the posi-action control handle and the safety latch counterclockwise to allow the top to be lowered. See Figures 41 and 42.

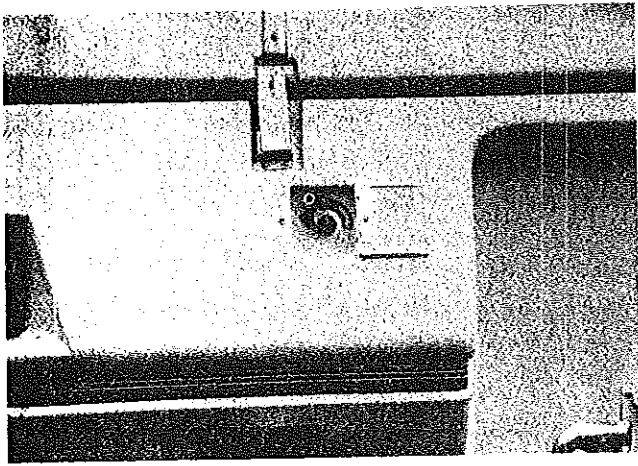

FIGURE 41

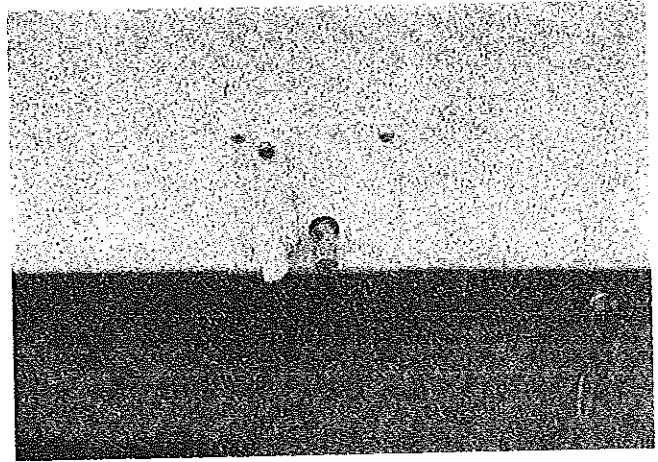

FIGURE 42

34. Rotate the crank handle in a counterclockwise motion and lower the top to within one foot of the trailer. Engage the crankshaft hook or turn posi-action control handle clockwise to the open position to hold the top.

WARNING:

Keep a constant inward pressure on the crank handle to prevent the handle from backing off the crankshaft. When lowering the top **DO NOT RELEASE THE CRANK HANDLE** without engaging the posi-action control on Americana series or the crankshaft stop located adjacent to the center crankshaft on Pioneer series. Bodily injury could result if the crank handle is released or backs off the crankshaft when raising or lowering the top.

35. Tuck in any tent fabric which may have worked its way out between the rooftop and trailer. This is important because if the tent fabric is pinched between the top and the aluminum rail it can become worn or discolored. Remove the crankshaft stop or turn the posi-action control counterclockwise and crank the top down fully. Close and secure crankshaft cover door.

IMPORTANT:

If the top will not seat properly onto the trailer, **DO NOT force it.** Raise the top to approximately one foot and recheck tent distribution.

36. Stow the crank handle, lock the doorstep and then latch the four top latches.

37. Adjust the tongue jack so that the trailer tongue is higher than the vehicle hitch ball.

38. Back the vehicle close to the trailer and set brake.

39. Using the tongue jack, lower the trailer tongue onto the ball hitch of the vehicle. Engage the coupler release handle by pressing down into the locked position. The coupler has a hole in it for a safety clip or padlock to be inserted for trailer theft protection.

40. Retract the tongue jack wheel fully by turning the handle counterclockwise until it stops, pull the release pin and swing the tongue jack up to the travel position. Bring the tongue jack handle up and over the tongue jack to store.

41. Attach the safety chains so they "crisscross" under the ball.

42. Connect the electrical pigtail to the mate.

43. Check to see that all lights on the trailer are functioning properly.

SYSTEMS AND SPECIAL FEATURES

TRAILER L.P. GAS SYSTEM

Liquid propane gas is used in your trailer for three basic reasons: it is inexpensive, portable, and burns with intense heat. This system has been checked at our factory and by your dealer to insure its safety. Except for the simplest maintenance, this system should be checked by an authorized L.P. gas supplier should any problems develop. Due to the importance of this system and the safety precautions built into it, we feel it best to take a little time to describe it to you.

A. Gas Bottle

The L.P. gas is stored under pressure in the gas bottle located on the tongue of your trailer. This bottle should be kept free of rust at all times. If rust should develop on the bottle, the area should be cleaned completely of the rust, primed, and repainted white. Quite naturally, the service valve on top of the tank should always be closed when the tank is not in operational use, and especially when in transit.

Typical Gas Line Routing

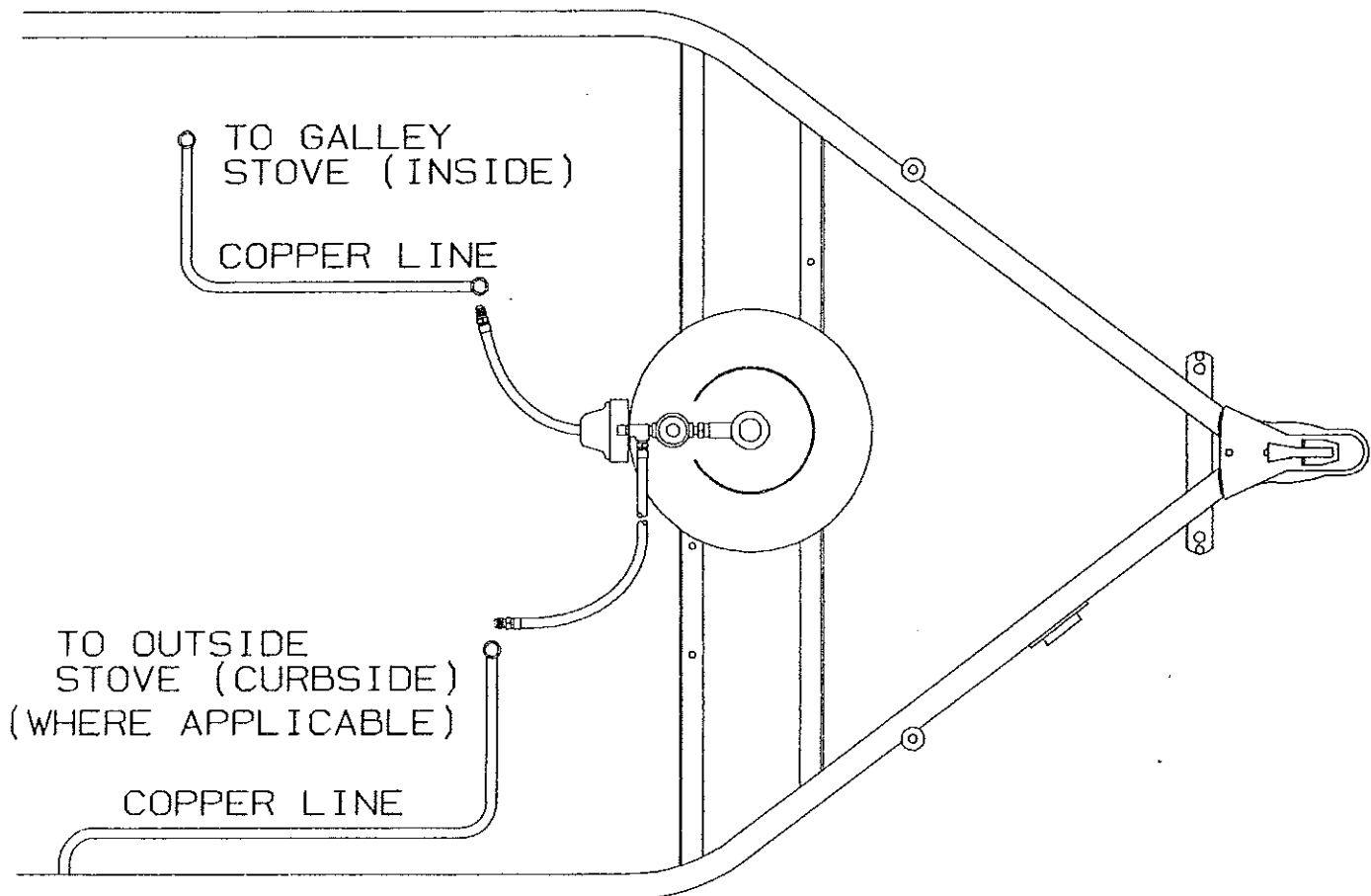

In order to change an L.P. gas bottle, follow these eight steps:

WARNING:

Do not smoke while changing the L.P. gas bottle and extinguish all surrounding open flames to avoid the possibility of fire and/or explosion.

NOTE:

Position L.P. tank with safety valve pointing away from trailer. Additional fittings are required as appliances are added i.e., water heater, furnace, refrigerator.

1. Turn off the L.P. gas at the burners. Be sure to check all three.
2. Close the valve on the L.P. gas bottle by turning it in a clockwise direction.
3. Disconnect the regulator to the L.P. gas bottle, using a suitable wrench.

NOTE:

These are left-hand threads. Turn clockwise to loosen.

4. Loosen the wing nuts from the J-bolts and remove the empty gas bottle.
5. Carefully place the full L.P. gas bottle on the tongue support and secure with the J-bolts and wing nuts loosened in Step 4.
6. Using a suitable wrench, attach the regulator (with the vent facing down) to the L.P. gas bottle.

NOTE: Regulator threads are lefthand threads. Turn counterclockwise to tighten.

7. Open the valve by turning it in a counterclockwise direction slowly.
8. Check for leaks by using a soap suds solution on all gas system fittings. We suggest that all gas system fittings in the trailer be checked for leaks with a soapy solution each time a gas bottle has been changed, every 30 days, or after the trailer has tracked over rough terrain. If the soapy solution is used and a leak is indicated by bubbles at a connection, tighten that particular connection sufficiently to stop the leak. If bubbles persist, close the L.P. gas bottle valve and contact your Fleetwood folding trailer dealer or L.P. gas supplier for assistance.

CAUTION:

Do not check copper and brass plumbing lines and fittings for leaks using ammoniated or chlorinated household type detergents. These can cause cracks to form on the line and brass fittings.

If a leak is suspect in the trailer, you will notice that L.P. gas has a distinctive odor. Should this be encountered, follow these directions:

1. Open the door and exit the unit, leaving the door open.
2. Close the valve on the L.P. gas bottle.
3. Do not touch electrical switches.
4. Extinguish any open flame.
5. Allow the trailer to ventilate thoroughly.
6. Check all stove valves to insure they are in the "off" position.
7. Check all pilot lights to make certain they are burning.
8. Check system for leaks by following steps outlined in Item 8 above.

B. Gas Bottle Regulator

The gas bottle regulator is the heart of your L.P. gas system. It is an automatic device with working parts which move continuously. Consequently, it requires more care, protection, and attention than any other part of the system. The basic function of the regulator is to take a high and varied inlet pressure from the gas cylinder and reduce it to a safe and consistent low outlet pressure to the gas appliances. Whatever the pressure is in the gas bottle, and it will vary due to atmospheric conditions, the regulator's job is to reduce it to 6.35 ounces or 11" water column outlet pressure, and supply fuel downstream at this pressure in whatever volume is required to efficiently operate each appliance as the demand is made.

The regulator is equipped with a vent because it is constantly "breathing." That is, the diaphragm of the regulator moves down and draws air into the bonnet or adjustment spring housing. When the diaphragm moves up, the air is expelled through the vent. In the event that excess pressure builds up in the lower housing or body of the regulator, a relief mechanism vents it to the atmosphere. It is imperative, therefore, to check the vent frequently to be sure it is clean and free of water, corrosion, or obstructions as clogging is the most common cause of regulator malfunction. If the vent does become clogged, it can easily be cleaned with a toothbrush. In addition, your regulator should be checked periodically by a competent L.P. serviceman to be sure that it is properly adjusted and in safe working condition. By following these simple precautions, your regulator will give you years of trouble-free service.

WARNING:

If the regulator vent becomes plugged, excessive pressure will cause the appliance to leak, making fire and/or explosion possible and causing subsequent damage to the appliance.

C. How Should the Regulator Be Mounted?

The regulator will function regardless of the position in which it is mounted; however, the recommended mounting position is with the vent vertically down or in a direct line opposite the inlet. If for any reason this is not possible, bear in mind that it is extremely important that the vent be pointed in a direction which results in the least likelihood of dirt, water, or other foreign materials getting into the regulator. It is also important to install the regulator in a position in which the cover cannot possibly become a receptacle for water or other foreign materials.

D. What is Freeze-Up?

A regulator does not freeze, nor will L.P. gas; however, as the gas passes through the regulator, it expands and cools, and moisture in the gas or in the regulator will turn into ice. This ice can build up and totally or partially block the orifice and thus partially or totally block the fuel supply. There are a number of things you can do to prevent this type of freeze-up:

1. Before it is filled, Be sure the L.P. cylinder is totally free of moisture by drying any visible water around the valve area.
2. Be sure the cylinder is not overfilled. Insist that the bottle never be filled beyond 80% liquid level.
3. Keep the valves on an empty cylinder closed.
4. Have your L.P. dealer purge the cylinder if freeze-up occurs.
5. If necessary, have your L.P. dealer inject methyl alcohol in the cylinder.

6. Keep the cylinder in an upright position.
- E. If a gas bottle is overfilled, a built-in pressure mechanism on the bottle will allow excess gas to escape. It is imperative, therefore, that once bottles have been filled that they always be stored outdoors in an upright position whereby complete ventilation is possible. As an example, if a bottle is filled during extremely low temperatures, an increase in temperature will allow the gas to expand and possibly trigger the release valve. The presence of this gas in a confined area could result in fire or explosion caused by exposure to an open flame.

WARNING:

The water heater and furnace combustion air exhaust ports may be extremely hot during water heater and furnace operation. Do not touch these outlets or allow any material to come in contact with, or cover, either the air intakes or exhaust ports while operating the water heater and/or furnace.

TRAILER ELECTRICAL SYSTEM

The electrical system of your folding trailer is broken down into two separate and distinct functions - the 12 volt direct current and 110 volt alternating current. The 110 VAC is used solely for the operation of interior 110 VAC receptacles. The 12 VDC is used for all other functions including running lights, interior lights, and the operation of 12 VDC appliances (i.e., furnace). By using the power converter, 110 VAC is converted to 12 VDC for the operation of interior lights and optional furnace.

A. 12 Volt Vehicular Electrical Circuit

The 12 volt DC electrical circuit is dependent on the tow vehicle's battery or an extra battery. Frequent and regular checks of the vehicle battery should be made to assure electrical system stability. We suggest the following checks:

1. Battery terminals and posts free from corrosion.
2. Battery terminals securely fastened to the battery posts.
3. Battery water level.
4. Battery voltage at the level specified by the vehicle manufacture.

Before each trip, make an operational check of all DC electrical functions of the trailer: turn, stop, side marker, and taillights. If a bulb does not light, remove the lens cover from over the bulb not functioning. Most often, bulb replacement will cure the malfunction; however, should the malfunction persist, secure the aid of a voltmeter and the wiring diagram contained herein and check the DC voltage and/or continuity of the circuit. Repair or replace as required.

B. 115 Volt AC Power Supply

The 115 volt AC power cord can be plugged into a park supply power source for the operation of interior and exterior receptacles only. The converter will change the 110 volt AC park supply to 12 volt DC current for interior lighting and optional furnace operation. Please refer to "Setup Instructions - Electrical and Water Hookups" in this manual for additional operation and use of the power converter.

Each Americana and Pioneer model trailer is equipped with a 110 volt AC exterior outlet for your convenience. This outlet is wired in series with a Ground Fault Interrupter. This device is intended to protect you against the hazards of line to ground electric faults and electrical leakage shocks. Materials used to insulate appliances and devices can deteriorate over time or develop cracks or weak spots that could allow electric current to "leak" through the insulation. Should a circuit or appliance develop a potential shock hazard of this type, the GFI device is designed to disconnect the outlet (and other outlets on the same circuit), limiting your exposure time to the shock hazard

caused by current leakage to ground.

The GFI device does not prevent electric shock, nor does it protect a person who comes into contact with both "hot" and neutral sides of the circuit. It does not protect against electrical circuit overloads.

Test the GFI at least once a month while operating on 120 volts AC. To test the GFI:

* Push the "TEST" button. The "RESET" button should pop out, indicating that the protected circuit has been disconnected.

* IF THE "RESET" BUTTON DOES NOT POP OUT WHEN THE TEST BUTTON IS PUSHED, A LOSS OF GROUND FAULT PROTECTION IS INDICATED. DO NOT USE THE OUTLET OR OTHER OUTLETS ON THE SAME CIRCUIT. HAVE THE TRAILER ELECTRICAL SYSTEM CHECKED BY AN AUTHORIZED FLEETWOOD FOLDING TRAILER DEALER OR BY A QUALIFIED ELECTRICIAN. DO NOT USE THE SYSTEM UNTIL THE PROBLEM HAS BEEN CORRECTED.

* To restore power push the "RESET" button.

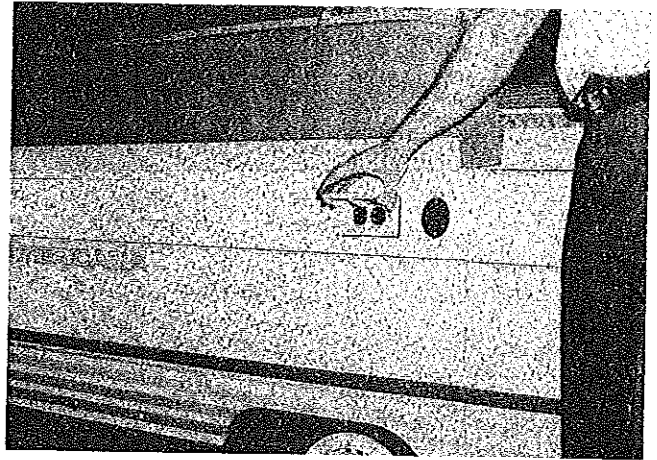

NOTE: If the exterior outlet doesn't work, check the GFI. Reset it if necessary. If the GFI continues to trip, have the trailer electrical system checked at an authorized Fleetwood Folding Trailer Dealer or by a qualified electrician.

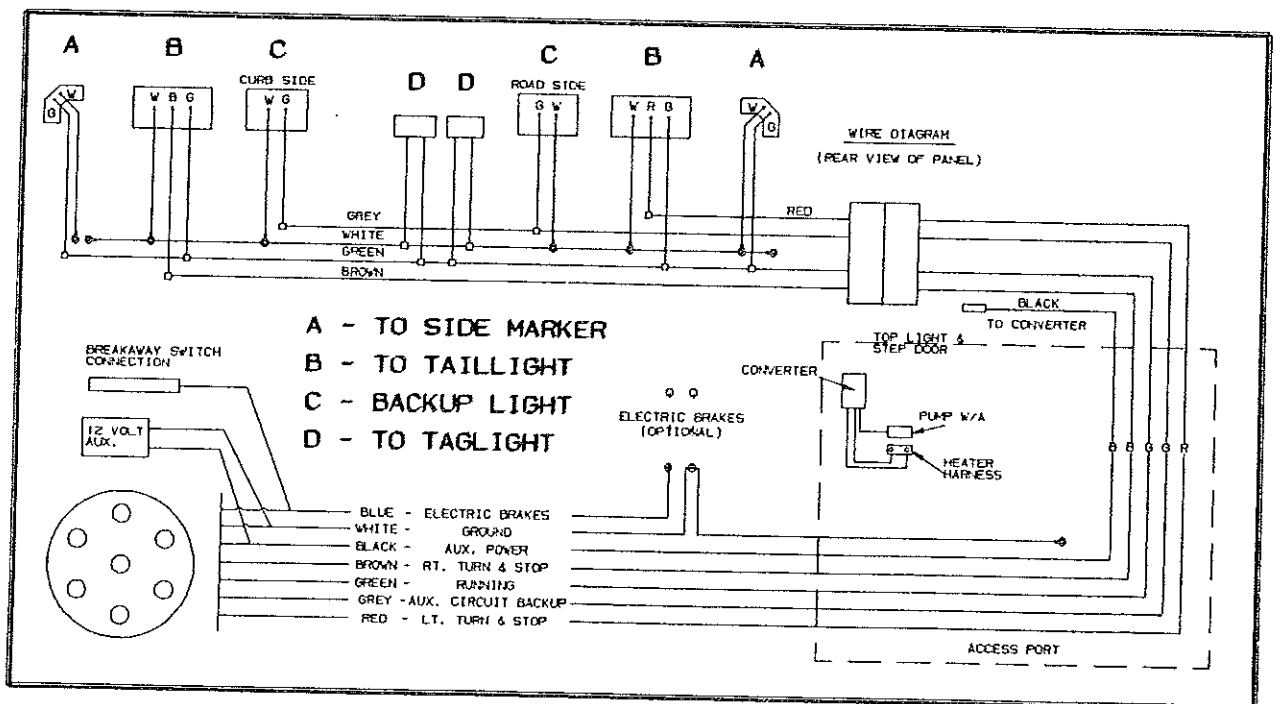

General Trailer Wiring Diagram

WATER SYSTEM

Fresh water may be supplied to your trailer sink (and tub and shower unit in the Arcadia and Williamsburg model) from one of two sources - the water tank or the city water hookup. Fixtures for both of these are located beside each other on the roadside body panel and are marked accordingly. When the city water is turned on, it will bypass the internal water tank with the exception of the water heater only). In order to be sure the water heater is filled, it is wise to open the hot water faucet slightly to allow the escape of trapped air.

A. Water Tank System

To insure complete sanitation of the potable water system, we suggest the following procedure be used on a new system, one that has not been used for a period of time, or one that has become contaminated.

1. Prepare a chlorine solution using one gallon of water and 1/4 cup of Clorox or Purex household bleach (5% sodium hypochlorite solution).
2. Pour one gallon of solution into tank.
3. Complete filling of tank with fresh water.
4. Open the faucet until all air has been released from the pipes and entire system is filled. Pump water up to the sink.
5. Allow to stand for three hours.
6. Drain and flush with potable fresh water.
7. To remove any excessive chlorine taste or odor which may remain, prepare a solution of one quart vinegar to five gallons water and allow solution to agitate in the tank for several days by vehicle motion.
8. Drain tank and again flush with potable water.

NOTE:

The built-in water tank is equipped with a screen filter which is located in the outlet fitting or at the pump. The filter should be cleaned periodically to insure maximum pump efficiency. Contact your dealer for the removal of this filter.

Once the internal water system has been cleaned, flushed, and refilled, water can be pumped by raising and lowering the pump handle. When using the city water supply, depress the pump handle which will allow city water to flow freely.

Continual city water flow can be obtained by rotating the hold-down rod over top of the pump handle as shown in Figure A & B. This will allow for both hands to be free for kitchen type chores such as washing dirty dishes.

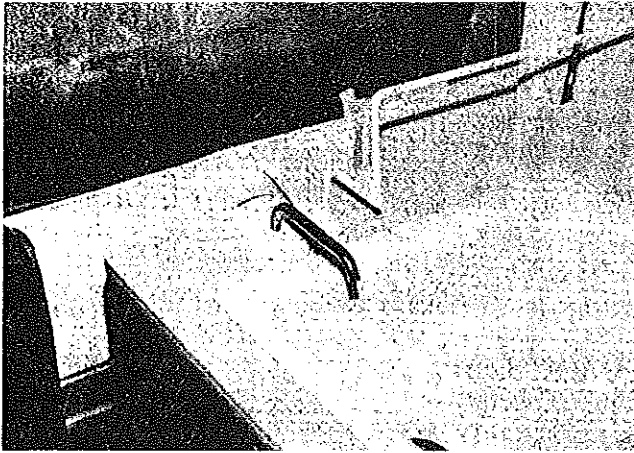

FIGURE A

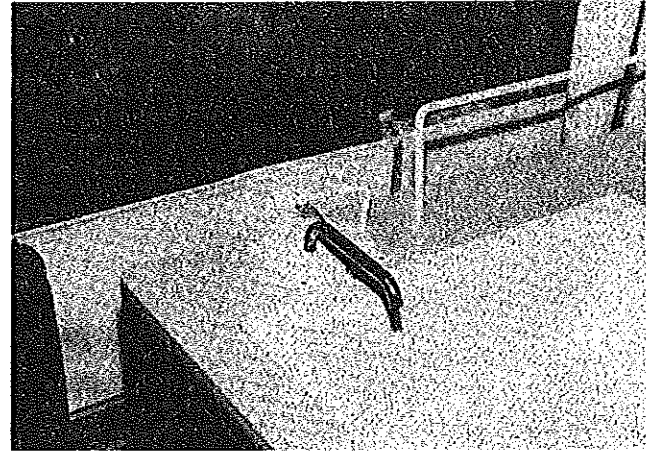

FIGURE B

B. Sink Drain

The outlet port for the sink drain is located on the same side of the trailer as the sink and the location is identified with a "drain" decal affixed to the body panel. The sink can be drained by simply removing the plastic protective cap from this fitting and allowing the water to flow freely from the sink. Please note that this fitting is threaded to allow the fastening of a rubber hose in order to drain the sink into a park-provided facility or waste container.

C. 12 Volt Electric Demand Water Pump (Arcadia, Williamsburg and Sequoia Models Equipped with Factory-installed Water Heaters Only)

The electric demand water pump in your unit is warranted solely by its manufacturer. The electric pump can be activated for use by pushing the switch button located on the roadside seat panel. Once the unit is activated, it will automatically switch on and off depending upon water use. Instructions for the specific care, use, and service of this component are enclosed with your trailer. This electric water pump is only to be used when a city water hook is not available and water must be drawn from the storage tank and water heater.

IMPORTANT:

Do not allow the electric water pump to run when the water system is dry. Subsequent damage to the pump mechanism will result.

D. Trouble-Shooting the Water System

Water system problems usually fall into two categories: mechanical system problems and problems caused by neglect. System problems are usually the result of road vibration and campsite water pressure variations. Problems of neglect usually stem from failure to clean filters, improper winterization, and poor maintenance. Most water system problems can be avoided by conscientious maintenance.

1. Leaks

Vibration, flexing, and twisting while traveling can work pipe fittings loose. If the water pump runs when a faucet is not open, suspect a leak. Be sure the tank drain valves are tightly closed. Leaks occur most often around threaded fittings. If necessary, tighten or clean and tighten the fittings. Do not overtighten fittings. Connections at galley and lavy fixtures should not be tightened with a wrench. They will normally seal with hand-tightening. If a leak persists at one of these fittings, disconnect it completely and check for mineral deposits or other foreign matter at the seating surfaces. Clean the surfaces thoroughly and reinstall the

fitting.

2. Clogged Water Filter

Dirt, mineral scale, or organic matter are filtered out of the fresh water system by an in-line water filter on the inlet side of the water pump. If you suspect a clogged filter, it is easily removed and cleaned.

- a. Loosen the clamp at the inlet of the filter
- b. Pull the water line off the filter
- c. Unscrew the filter from the water pump
- d. Turn each end of the filter and pull apart
- e. Flush out and clean screen
- f. Reverse procedure to install
- g. Operate the water pump and check for leaks

3. Water Pump Trouble Shooting

The water pump in your trailer is a durable device that will operate for years with little attention. Most water pump problems can be solved by a common-sense approach. The following is a discussion of possible trouble spots and what to do.

4. Pump Motor Does Not Operate

Your trailer has two water pump switches - one master switch on the seat bench panel and one in the pressure sensing assembly in the pump head. Be sure the "Water Pump" master switch is on. Even though the pump operates automatically when a faucet is opened, the pump master switch has to be on for that to happen.

Check the fuse. The water pump fuse is located in an in-line fuse holder near the pump. If it is blown, there is a reason for it. Check the pump wiring for shorts. Do not replace the pump fuse with a fuse rated for more than 7.5 amps.

Check for disconnected or corroded wires or terminals. Clean and reconnect if necessary. In cold weather, check for pump freeze up. If water is frozen in the pump, thaw it by placing a lighted bulb near the pump head. **Do not use a torch or other open flame.**

5. Pump Motor Runs but No Water Flows

- a. Be sure there is water in the fresh water tank.
- b. Check the filter. If it is clogged, remove it and try cleaning it as a temporary fix. If that doesn't work, it must be replaced.
- c. Check inlet and outlet hoses and fittings. Look for kinked or collapsed hoses or loose clamps that could be letting air into the system. Avoid storing anything in the water pump area. A heavy item could flatten a hose or damage the inlet or outlet hoses and fittings.

6. Pump runs but Water Sputters

- a. This is normal after an initial filling of the fresh water tank and lines. It should stop after a few seconds.
- b. If sputtering continues, the water tank may be almost empty. Add water if necessary.
- c. If sputtering continues, check for air leaks in the inlet side of the pump.

7. Pump Cycles On and Off When All Faucets Are Closed

- a. Check for leaks in the water lines.
- b. Be sure tank drain valves are tightly closed.
- c. The pump may have an internal leak.

8. Pump Does Not Shut Off

- a. Water tank may be empty.
- b. Check battery condition. A low battery will allow the pump to run but not develop enough pressure to shut off.
- c. The pump switch mechanism may be stuck. Gently tap the switch cap on the end of the pump with a screwdriver handle.

9. Pump Head Leaks

- a. Tighten screws in the pump head assembly. **Do not overtighten.**
- b. The head may be cracked. This can be caused by stress failure, but is more likely caused by water freezing in the pump head.

10. Pump Does Not Prime

- a. Water tank may be empty.
- b. Filter may be clogged.
- c. Inlet hoses may be kinked or collapsed.
- d. Failure to prime may be caused by internal pump valve failure or foreign material lodged in a valve seat. These conditions require pump disassembly.

E. Tub and Shower Unit (Arcadia and Williamsburg Models Only)

I Shower Curtain Board Installation

- a. Remove the shower curtain board from the storage location on the tub by grasping the edge of the board and lifting. See Figure C.
- b. Holding the board securely, insert back edge into retaining bracket located in top assembly. See Figure D.

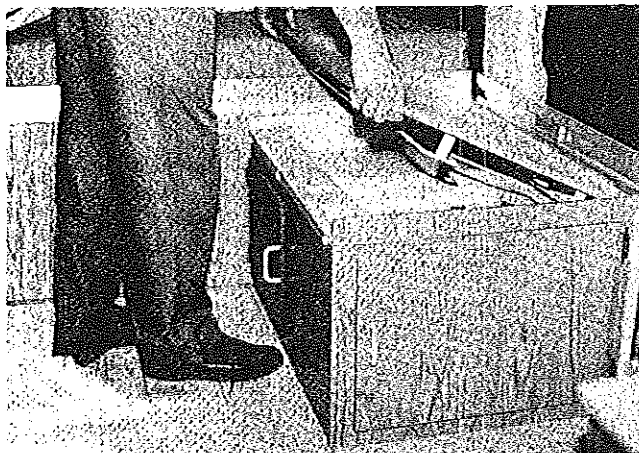

FIGURE C

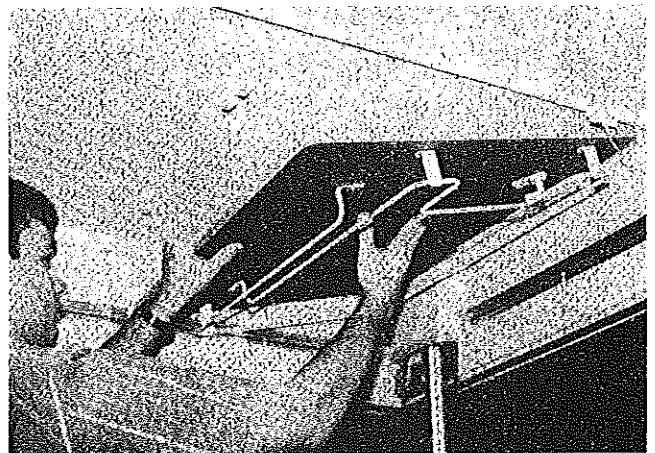

FIGURE D

- c. Press the shower curtain board flush against the top assembly. While holding in position, rotate the two (2) twisting fasteners 90 degrees in order to retain the shower curtain board in the top location. See Figure E.

CAUTION:

Hold the shower curtain board firmly when placing in the top usage position. Accidental slippage may result in damage to the shower curtain board, tub, and/or personal injury.

II. Shower Curtain Installation

- a. Attach the shower curtain hooks to the curtain rod as shown in Figure F.
- b. Assemble the shower curtain to the hooks.

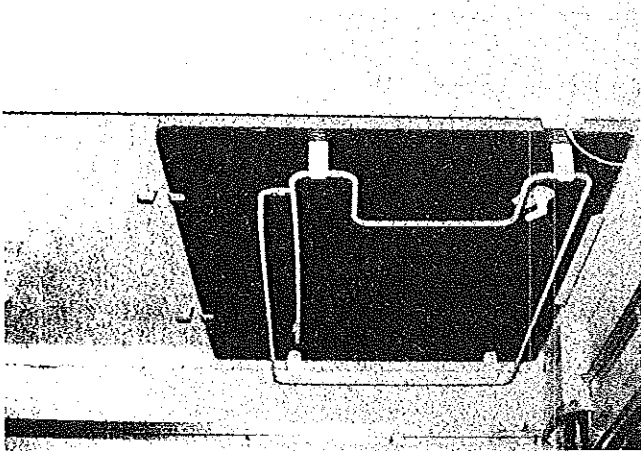

FIGURE E

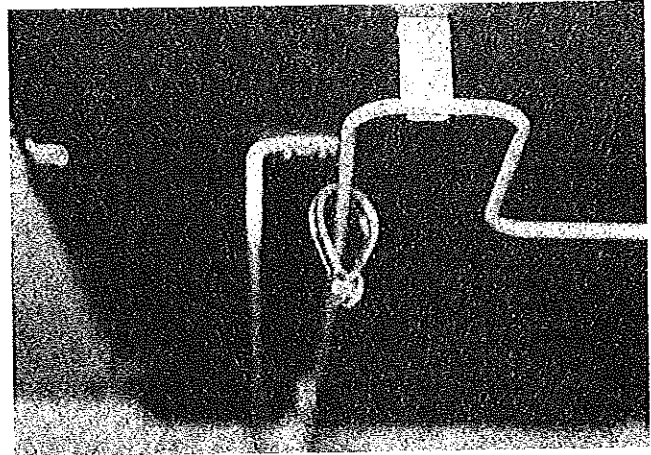

FIGURE F

NOTE:

When the shower is not in use, the curtain can be left attached and conveniently stored by lowering the shower curtain board to the travel position; however, the curtain should be dry before storing to prevent mildew.

III. Portable Toilet Privacy Curtain (Where Applicable)

The portable toilet privacy curtain can be installed in the tracks located in the top assembly by following this simple procedure:

1. Slide all carriers with the hooks onto the I-beam, making sure that all hooks face the same direction. See Figure G.
2. Assemble the curtain stop to I-beam by sliding stops onto the ends of I-beam, locate approximately 1/4" from each end of I-beam, and tighten thumb screw tight with your hand. See Figure H.

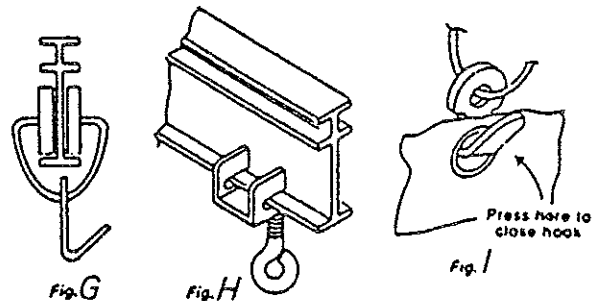

IMPORTANT:

If pliers are used, care should be taken not to overtighten. See Figure H.

3. Assemble curtain to track by placing carrier hooks on track through small eyelets in curtain. Hooks may be squeezed together with thumb and forefinger after the curtain is hung to secure it to the hook. See Figure I.

IV. Shower Operation (Arcadia and Williamsburg Models)

1. Connect a garden hose (not supplied) to the tub drain located on the lower portion of the right front body panel and route to a park-supplied drainage receptacle or a suitable waste container.
2. Connect the shower head hose to the tub fitting and hand tighten.
3. Adjust the shower curtain to insure that the total area around the tub is sealed and the curtain bottom is inside the tub.
4. Adjust the water temperature.

On Arcadia and Williamsburg models the bathtub may be converted to additional counter space by placing the shower curtain board on top of the bathtub.

NOTE:

When your trailer is being stored for extended periods of time, it is recommended that the shower curtains be removed from the unit, folded, and stored indoors under fairly constant temperatures. Extremes of temperatures could have an adverse effect on the plastic material.

F. Draining and Winterizing the Water System

Your dealer can advise you concerning specific winterization procedures and products for your climate area or the areas through which you will be traveling. Your dealer may also provide winterization service for all appliances and systems in the trailer.

If you choose not to travel during the winter and will be storing your trailer during periods of freezing temperatures, follow a thorough winter storage procedure.

Protecting the plumbing systems in your trailer is the most important aspect of long-term winter storage. Extensive damage to the plumbing fixtures and components as well as other potential problems can be avoided by proper draining and antifreeze protection. The following is a procedure checklist you can follow if you prefer to winterize your vehicle yourself.

1. Drain the fresh water tank by opening the water tank drain valve. Leave valve open.
2. Turn the water pump on (12 volt DC power on). Open a cold water faucet. When the flow of water stops, turn the pump off.
3. After opening hot and cold water faucets, open the drain valves on HOT and COLD water pipes. These valves are located on the underside of the trailer directly in front of the axle. (Water line drain valves only applicable in trailers so equipped.)
4. Drain the water heater by opening the drain valve at the bottom of the heater and open the safety valve. Open the hot water faucets. Note water heater instructions for exact location of drain valve.
5. When each faucet has been opened, drained, and closed, close the water line drain valves and freshwater tank drain valve.
6. Disconnect the shower hose assembly.

7. Be sure ALL water from ALL plumbing fixtures has been drained.

On units not equipped with a water heater or tub and shower unit, the water system may be drained by simply turning the petcock located on the bottom of the water storage tank under the trailer and allowing all water to drain out.

On those units equipped with a water bottle and not an installed tank, it is only necessary to drain the lines and simply empty the bottle.

CAUTION:

Draining the water system alone will not provide adequate cold weather protection. If the trailer is to be unheated during freezing temperatures, consult your dealer for the best winterizing procedure for your climate. Your dealer can winterize your trailer for you or can supply you with one of the special antifreezes which are safe and approved for use in RV water systems. Follow the instructions furnished with the antifreeze.

WARNING:

Do not use automotive or windshield washer antifreeze in the trailer water system. These could be harmful if swallowed.

8. Pour approximately two gallons of approved RV water system antifreeze into the fresh water tank. Be sure tank drain valve is closed.
9. Turn the water pump master switch ON.
10. Open each cold water faucet, run the water pump and let about a cup of antifreeze solution flow continuously through each faucet. Close each cold water faucet.
11. Check the antifreeze level in the water tank. Add antifreeze solution if necessary.
12. If your trailer is equipped with a water heater bypass:
 - a. Turn water pump switch OFF.
 - b. Completely drain water tank and water heater. Open water heater relief valve to drain water heater.
 - c. Pour approximately two gallons of non-toxic RV-approved antifreeze into fresh water tank.
 - d. Open all hot and cold water faucets to relieve pressure.
 - e. Close all faucets.
 - f. Engage water heater bypass connection. This can be achieved by disconnecting the two swivel elbow connections from the water heater, (hot & cold lines). Attach bypass line onto the two swivel elbows.
 - g. Turn water pump ON.
 - h. Open hot water faucet farthest away from water tank. When antifreeze appears, let about one cup run down drain to winterize trap. Repeat this at all other hot and cold water faucets including the shower.
 - i. Turn water pump OFF.

- j. Open water faucet to relieve pressure then close.

Winterizing of the fresh water system is complete.

When filling the plumbing systems with antifreeze, be sure to open and operate all fixtures and valves allowing the antifreeze solution to flow freely.

Pour a cup of antifreeze solution down each sink and tub drain.

Install all protective caps: water tank fill; city water inlet cap

G. Water System Versatility (Sequoia with Factory-installed Water Heater, Arcadia and Williamsburg Only)

The water system in your Williamsburg trailer is a high-quality, versatile system. To acquaint you with the various methods of operation, a discussion of each follows:

1. City Water Supply

- a. Connect a garden hose (not furnished) to the campground-provided faucet and city fitting on the roadside panel of the trailer.
- b. Turn the city water supply "on" and allow the system including the hot water tank to fill.
- c. Light the water heater by following the instructions printed inside the vent cover.

IMPORTANT:

Be certain that the water heater is filled prior to lighting to prevent appliance damage.

- d. Simply turn the sink or shower faucet knob approximately 1/4 turn to draw water.

2. Use of the water tank. (Use when campground city water supply is not available.)

- a. Clean and fill the plastic water tank according to the instructions in Section A above "Water Tank Systems".
- b. Connect trailer exterior power cord to 115 VAC park supply and set the power converter to "convert."
- c. Engage the electrical demand pump by pressing the switch button located on the roadside panel. Once the hot water tank is filled and all faucets closed, the pump will automatically shut off.
- d. Light the water heater by following the instructions printed inside the vent cover.
- e. Simply turn the sink or shower faucet knob approximately 1/4 turn to draw water. The electric pump will automatically engage to provide needed water pressure.

NOTE:

Continual running of the water pump once all water faucets have been closed and the water heater is full indicates a leak in the system. By following the instructions outlined in the electrical pump section of this manual, simple leak problems may be resolved. If the leak cannot be corrected, your authorized Fleetwood folding trailer dealer can assist you with a

3. When a 110 VAC power supply is not available, your water system may be used exactly as described in #2 by connecting the trailer 12 VDC power supply to a tongue-mounted battery or tow vehicle outlet i.e., cigarette lighter.

WARNING:

The hot water drawn at the sink is directly out of the water heater. The temperature of the water could be as high as 150°. Scalding could occur if the hot water is not diluted. **DO NOT** expose the body directly to the undiluted hot water.

WARNING:

Hydrogen gas can be produced in a hot water system served by this heater that has not been used for a long period of time (generally two weeks or more). Hydrogen gas is extremely flammable. To reduce the risk of injury under these conditions, it is recommended that the hot water faucet be opened for several minutes at the sink before using any electrical appliance connected to the hot water system or lighting any gas appliance. If hydrogen is present, there will probably be an unusual sound such as air escaping through the pipe as the water begins to flow. **THERE SHOULD BE NO SMOKING OR OPEN FLAME NEAR THE FAUCET AT THE TIME IT IS OPENED.**

IMPORTANT:

Never attempt to light the hot water heater if it is not filled. Permanent damage to the heater unit could occur and such damage would void the warranty.

TRACKING SYSTEM

A. Tires

CAUTION:

To provide maximum towing ease, tire life, and trailering safety, check the following items before each trip to and from the campsite:

1. Tires inflated to recommended pressure as indicated on the tire sidewall.
2. Wheel lugs securely tightened (70-80 footpounds for 8" tires; 80-90 footpounds for 10" tires).
3. A visual inspection of tire tread and walls for wear or cuts.

Please Note:

The tires on the Fleetwood folding trailer are warranted separately by the manufacturer. While the warranties of the various tire manufacturers vary in language, they in general provide that tires installed as original equipment at the factory are warranted to the owner to be free from defects in material and workmanship for the life of the tire tread. There is no warranty coverage for damages resulting from road hazards, etc.

If a tire warranty adjustment is required, the trailer owner should contact the nearest authorized representative of the tire manufacturer. In the event there is no local representative, the customer should follow the directions set forth in the tire warranty card packaged in each folding trailer or call DURO, 800-966-TIRE. A Fleetwood folding trailer dealer **MAY** be able to assist you in locating the tire manufacturer's local representative who can handle warranty adjustments. Requests for tire warranty adjustments **should not** be sent to Fleetwood Folding Trailers, Inc.

NOTE:

All Fleetwood folding trailers are capable of accepting different size tires. Prior to making any tire size changes, consult your dealer for tire size adaptability.

B. How to Change a Flat Tire

Tires may be easily changed in the following manner:

1. When possible, locate the trailer on level terrain and remove from the tow vehicle.
2. Block both front and back sides of the tire opposite the one needing changing.
3. Using the tongue jack, lower tongue end down as far as the tongue jack will allow.
4. Remove the hubcap from the tire you wish to change.
5. Using a 13/16" lug wrench, break loose the lug nuts.
6. Pull down rear stabilizer jacks, extend the stabilizer jack to near full extension on the side which will be changed. Extend the stabilizer jack on the side of the inflated tire just to the ground.
7. Rotate the tongue jack handle in a clockwise motion and raise tongue end up. Stop when tire to be changed is raised approximately 3/4" off the ground.
8. Take the lug nuts off using the lug wrench.
9. Slide the flat tire off and slide repaired, new, or spare tire onto the axle.
10. Start each lug nut by hand to avoid cross-threading and then use the lug wrench to draw the lug nuts reasonably tight.
11. Lower the tongue jack until the tire is on the ground. Using a lug wrench, draw the lug nuts tight (70-80 footpounds for 8" tires; 80-90 footpounds for 10" tires). See chart for proper sequence of torquing lug nuts.
12. Replace hubcap.
13. Release the stabilizer jacks and return to travel position.
14. Hitch trailer to vehicle. Pull the release pin and swing up the tongue jack to the travel position.

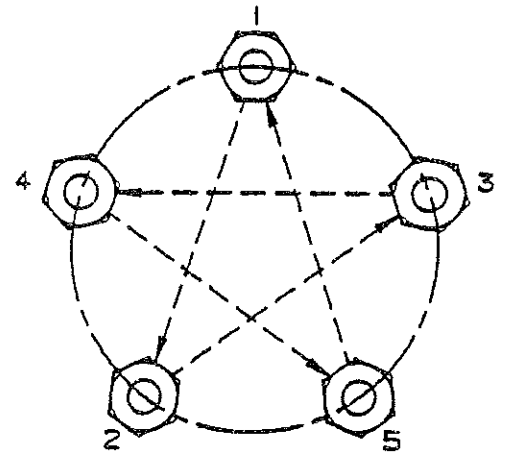

CAUTION:

After you have driven a short distance (approximately one or two miles), stop and recheck the lug nuts to insure they are securely tightened. Check again after 25 miles.

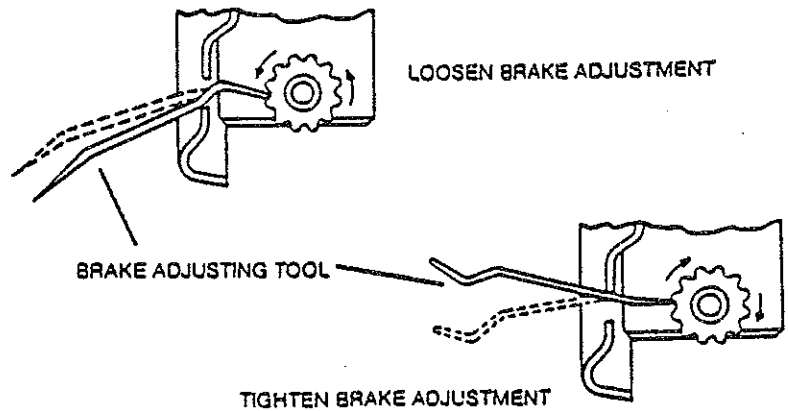
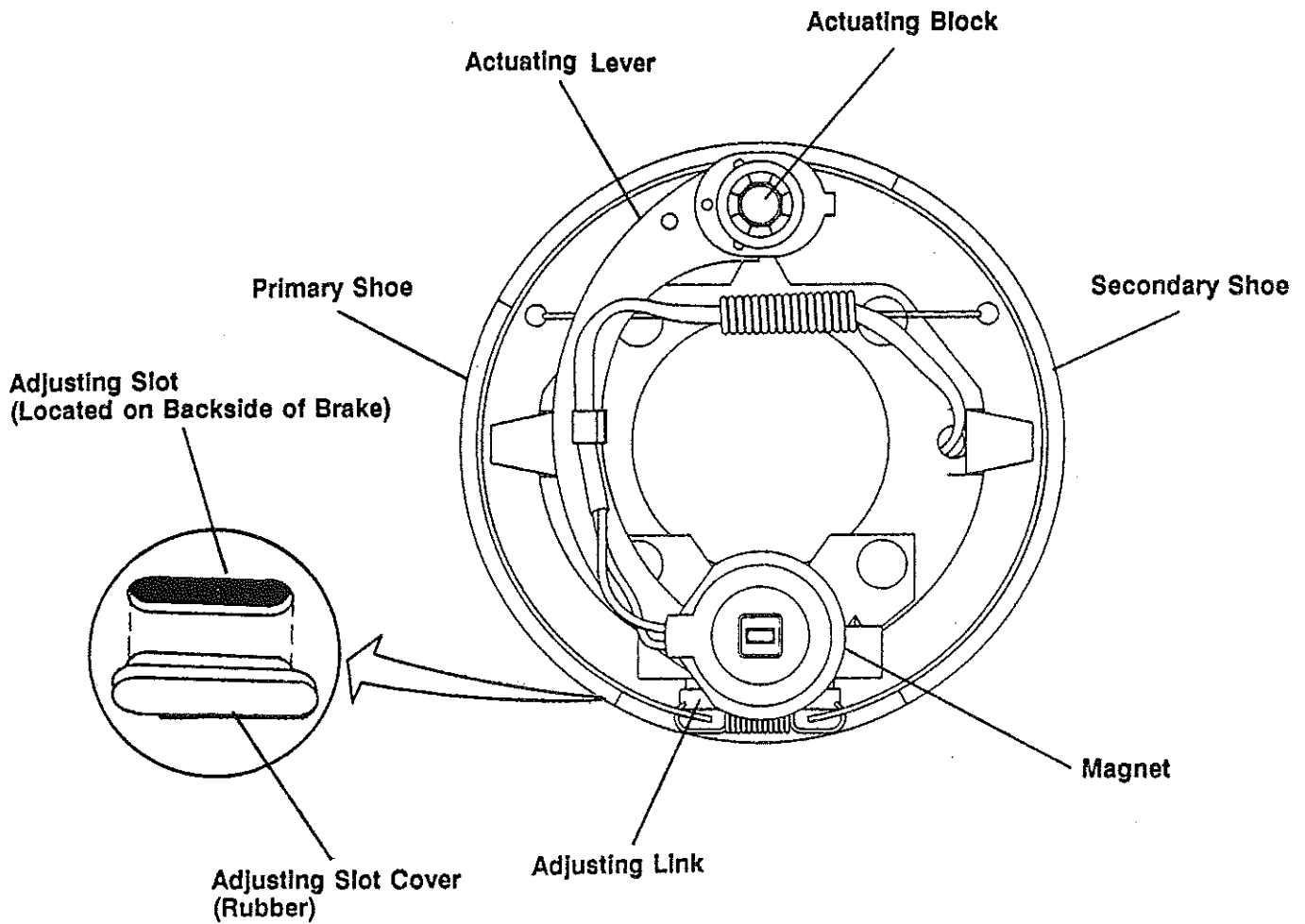

1. Brake Adjustment

Brakes should be adjusted after the first 200 miles and at 3,000 mile intervals, or as use and performance requires. The brakes should be adjusted in the following manner:

- a. Jack up one wheel and check that it rotates freely.

- b. Remove the adjusting hole cover from the adjusting slot on the bottom of the backing plate.
- c. With a screwdriver or a standard adjusting tool, rotate the star-wheel of the adjusting link by moving tool "down" to expand and tighten the brake shoes. Adjust shoes out until the pressure of the linings against the drum makes the wheel very difficult to turn.
- d. Now, rotate the star-wheel in the opposite direction by moving tool up until wheel turns freely.
- e. Replace adjusting hole cover and lower the wheel to the ground.
- f. Repeat the above procedure for the other brakes.

CAUTION:

Never crawl under the trailer while it is resting on trailer jacks.

Foregoing the "wearing in" procedural adjustments, the electric brakes need to be checked and adjusted as required, once a year.

NOTE:

Periodic brake adjustment is the consumer's responsibility.

2. Breakaway Switch (Where Applicable)

The breakaway switch is located on the trailer tongue. It has a steel cable (lanyard) fastened to it which will reach to the frame of the tow vehicle. This device is one of the most vital components on your trailer's braking system. It automatically applies the trailer brakes if the tow vehicle and trailer become uncoupled while in motion. The breakaway switch operates when a pull pin linked by the cable to the tow vehicle is separated from the switch. When the switch closes, power for brake application is transferred to the onboard trailer battery. The steel lanyard must be anchored to the tow vehicle when the trailer is hitched up. Secure this cable loop to the permanent frame of the tow vehicle or a part of the hitch that is non-removable. **Do not fasten the breakaway switch lanyard to the hitch ball or any other removable part of the hitch.** Remove the pull pin every three months and lubricate it with light oil. Before reinserting the pin, spray the inside of the switch with an electrical contact cleaner to prevent corrosion.

Test the breakaway switch operation before each trip as follows:

- a. Hitch the trailer to the tow vehicle.
- b. Pull out the breakaway switch actuating pin.
- c. Test brakes by attempting to drive away. The breakaway switch is functioning properly if the trailer brakes are activated.
- d. If the brakes are not activated, check that the trailer battery is connected and fully charged and the trailer brakes are properly adjusted.
- e. Obtain service repair if the trailer brakes do not operate after making these checks.
- f. Reinsert the breakaway switch actuating pin before towing the trailer.

WARNING:

Do not tow a trailer with a malfunctioning breakaway switch.

WARNING:

Do not leave the pull pin out of the breakaway switch for more than a few minutes or the battery will be drained. Do not use the breakaway switch as a parking brake.

D. Ball Hitch and Coupler

Maintain a coat of light grease on the ball hitch of your vehicle. This will induce longer ball hitch life and towing ease.

The coupler should be adjusted, when required, to maintain the coupler/ball snugness. With the coupler attached to the ball and the coupler release handle down in the locked position, adjust the lock nut (on the underside of the coupler) to compress spring to within 1/32" of solid. See adjacent figure.

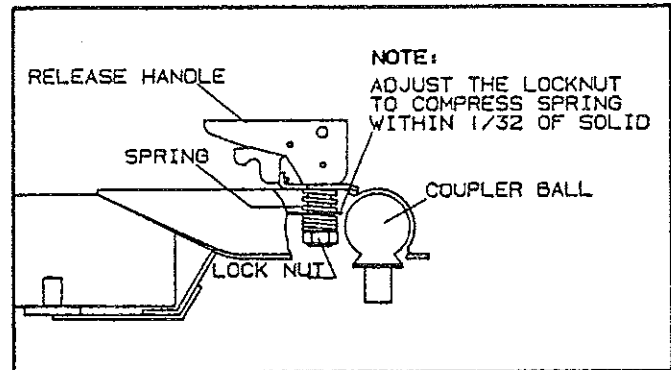

Make a visual inspection of the safety chains for damaged or corroded links; repair or replace as required. Insure the ball hitch is securely attached to the vehicle and the ball head is securely tightened.

E. Recommended Practices for Lubricating and Adjusting Wheel Bearings

IMPORTANT:

Wheel bearings should be checked before the initial camping trip and then every 2,000 miles or twice a season, whichever occurs first, and at the beginning of each camping season.

Lubrication

Proper lubrication is essential to all types of bearing application. The kind of lubricant used is governed by the design and operating conditions. The function of lubricants is mainly to:

- a. Reduce friction between moving parts.
- b. Carry away heat.
- c. Aid the seal in keeping lubricant in its place and keeping foreign matter out of the bearing.

Bearings will run the coolest and with the least friction when a minimum amount of the lightest bodied lubricant that will keep bearing surfaces apart is used. Heat in bearings is due to a number of causes such as: (a) too much lubricant, (b) too heavy lubricant, (c) too tight adjustment.

We probably will always have with us the man who says, "If a little is good, a lot is better." This is as great a fallacy in bearing lubrication as it is in medicine or anything else. If too much or too heavy a lubricant is used, there is bound to be an increase in temperature when the wheel starts to rotate, usually followed by leakage. An attempt to stop this by tightening the adjusting nut will increase the friction, thus still aggravating the condition until, in extreme cases, the bearing fails.

We know that our bearings have to function under high temperatures due to the electric brake heat, so we have chosen lubricants of such character that they will return to their original consistency when the bearing cools, with practically no oil separation. We use and recommend the following grease or its equivalent: Wolf's Head High Temperature Wheel Bearing Grease.

The manufacturing company recommends that wheel bearings be inspected and repacked every 2,000 miles or as required and at the start of every vacation season. A trailer sitting idle for a few months will collect some moisture in the hubs due to atmospheric conditions and this is the reason for inspecting and repacking the bearings at this time.

The relubrication of wheel bearings is possibly the most important service performed to the running gear. The two most important phases of this operation are cleanliness and proper adjustment.

Before disassembly of the hub, check wheel play and freedom of rotation. Extreme or excess play indicates a too-loose adjustment or a defective bearing. Too much drag in rotation of the hub could indicate tightness in bearing adjustment or a brake being adjusted too tight.

To begin disassembly, remove the dust cap. Next, remove the cotter pin and spindle nut. Jiggle the hub slightly to loosen the outer bearing. Usually the outer bearing will loosen up enough to be removed by hand. Pull the entire hub which contains the inner bearing and grease seal. Remove the inner bearing and grease seal by placing a brass drift or piece of wood through the small end of the hub and tapping gently until the bearing and seal is loose. Wipe all dirt and grease from the inside of the hub and the spindle.

Used bearings must be cleaned prior to relubrication. Various solvents are effective for degreasing. Successful processes employ kerosene, distillates, and chlorinated hydro-carbons. The solvent action of kerosene is limited, but it has the advantage of leaving a rust-inhibitive film on the bearing. After cleaning, bearings should be allowed to drain free of solvent which might dilute lubricants. Do not immerse the grease seal in any solvents, but wipe clean with a cloth.

WARNING:

Do not use above-described cleaning solvents near or around open flames as fire or explosion could occur resulting in serious bodily injury.

Carefully inspect cups (races) and cones (bearings) for pitting, scratches, excessive wear, or other damage. Do not replace a bearing unless you also replace its mating cup.

If at all possible, use a bearing packer to repack the cones. If this is not available, the bearings can be lubricated by hand if the grease is pressed into and around each and every roller. See Figure J. Additional grease within the hub is not required. Install the inner bearing in the hub and replace grease seal by tapping gently with a wooden block (see Figure K), making sure the seal is installed as it was before disassembly. Replace hub on spindle, taking care not to damage threads or grease seal. Replace outer bearing and spindle nut. Slowly rotate the hub in one direction or the other while tightening the spindle nut (maximum 50 footpounds torque) or until there is a slight bind to be sure that all bearing surfaces are in contact.

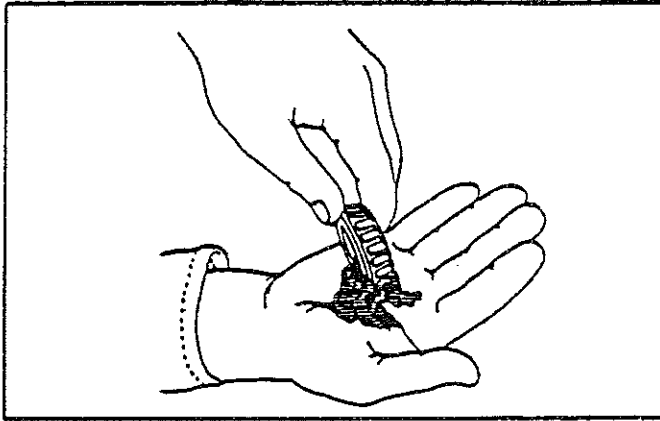

FIGURE J

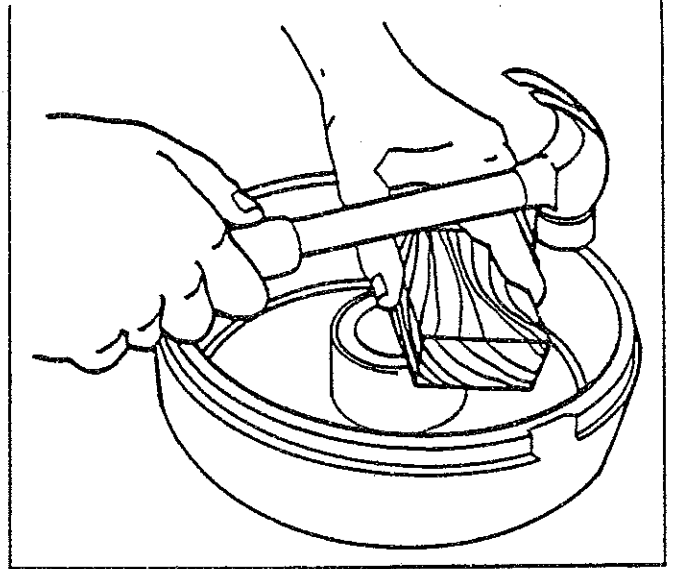

FIGURE K

IMPORTANT:

At this point the adjusting nut is backed off $1/6$ to $1/4$ turn or to the nearest locking hole or castellation. This will allow the wheel to rotate freely without excessive end play. The total amount of internal running clearance between the roller and the raceways of the bearings should be within $2/1000$ to $8/1000$ recommended limits. This can only be measured accurately with the use of special instruments, but by simply pushing inward and pulling outward on the hub several times a person should feel a very slight end play. If the bearings are too tight or too loose, they will fail prematurely. Install new cotter pin, bend to locked position, and drive on grease cap.

We wish to stress the point that the bearings used in the hubs of folding trailers are subjected to high speeds and heavy loads. For that reason, they must be maintained more frequently than before. We feel certain that maximum bearing life and performance will be consistently obtained if the methods of lubrication and adjustment we have described are followed.

LIFT SYSTEM

The lift system in your new Fleetwood folding trailer is a well designed, virtually trouble-free system if used properly and within the guidelines set forth in this owner's manual. Twenty years of engineering design and improvements have gone into this system. Although this system has remained basically the same since we have been manufacturing folding trailers, we have improved the design, efficiency, and material quality. For example, the four lift assemblies on your folding trailer are manufactured from high-quality stainless steel. The four long cable assemblies extending from the main screw shaft to each lifter are stainless steel in order to offset the severe road conditions of salt, chemicals, dirt, and so forth. The pulleys used in the lift system are all steel pulleys with steel needle-bearing inserts for long life and dependability. Contained within this section, therefore, are some hints and tips relative to the proper care of your lift system.

- A. Never crank the trailer up with weight on the roof except for a dealer-installed air conditioning unit. Additional weight placed on the top assembly while the unit is being cranked up can result in an unnecessary strain on the lift system causing cables to be stretched and the loss of proper height adjustment. Never raise or lower the roof with the stabilizer jacks set. This action can cause a bind on the trailer frame resulting in excessive pressure being placed on the four lift assemblies.

B. Maintenance

The only maintenance that will be necessary to perform to your lift system is an occasional lubrication of the pulleys contained within the lifts. This lubrication should be only a silicone spray and used very sparingly.

NOTE:

Excessive lubrication on the pulleys and lift arms can result in unsightly stains to the tent enclosure.

Left Front Corner

C. Top Adjustment

Height adjustment, if necessary, can be performed at each main cable adjustable pulley bracket. One bracket is located in each corner of the main frame tube area. Adjustments should be made as follows:

1. Crank top to approximately 12" high.
2. Extend front and rear bed assemblies approximately one foot past body rails.
3. Lower top down on extended beds until crank stops to relax cables.
4. Remove pulley pin and relocate pulley to an alternate hole position. (Each hole should add about 1 1/2" to that particular corner or a maximum of 3" adjustment available at each corner. Do not overadjust or canvas and weatherseals may be damaged.)
5. Raise top and return beds to travel position.

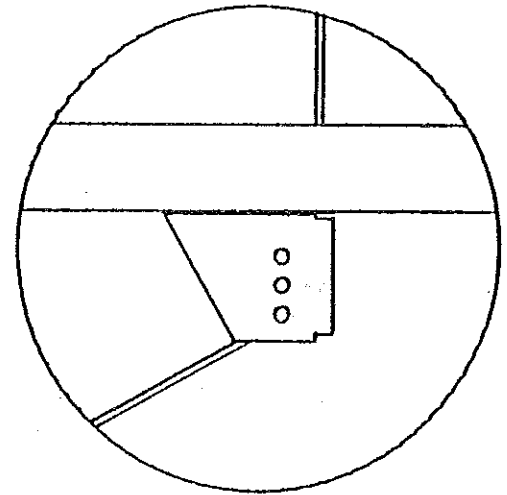

NOTE:

Fine adjustments can only be performed at the main drive train area. This adjustment should be performed by an authorized Fleetwood folding trailer dealer.

IMPORTANT:

We emphasize that any customer repairs to the lift system should only be done as a temporary measure. Your dealer should be consulted prior to performing any lift system service to prevent inadvertent damage to the system.

TENT ENCLOSURE

A. Care and Repair of Evolution 3 Tent Fabric

The tent enclosure on your unit is Evolution 3 fabric. This newly designed material is a strong, three-layer polypropylene laminate which will resist common stains, soil, mildew, and rot. The procedures set forth may be used to correct soiling or spot fabric leaking caused by accidental contact with insect repellents and sprays. Products containing surfactant e.g., insect repellents, suntan oils, can cause a loss of water repellency. This can easily be corrected by following the washing instructions outlined below:

1. Concentrated Leaking Areas of Evolution 3

Light brushing with a soft cloth will remove most dirt. For persistent soils:

- a. Wet soiled fabric with water.
- b. Wash with Surf detergent or Joy liquid. Dilute 1/4 cup cleaner per two gallons of water. Work into a lather with a sponge; lightly work the lather into the soiled area.
- c. Rinse thoroughly with copious amounts of water to remove all soap residue. Soap residue can cause fabric leakage.
- d. Air dry completely.

2. Severe Leaking of Entire Evolution 3 Section

- a. Remove entire contaminated section of Evolution 3.
- b. Take contaminated section to a laundromat capable of handling carpet and large rugs.
- c. Using 1/2 to 3/4 cup of Surf detergent or Joy liquid; wash sections of contaminated Evolution 3 through normal wash/rinse cycle.
- d. Allow washed section to air dry on trailer.

NOTE:

All washing of leaking Evolution 3 material is the consumer's responsibility and is not covered under normal warranty procedure. If the above procedures do not correct the leak, contact your nearest authorized Fleetwood folding trailer dealer for assistance.

If slight fabric leaking persists due to presence of soap residue, the area may be treated with a water repellent such as 3M Scotch Guard Fabric Protector. If slight fabric leaking exists at any seam, simply coat the affected seam with a small amount of K Kote seam sealer, available at your local K Mart or hardware store.

Accidental rips and tears in Evolution 3 tent fabric can be easily repaired by sewing or by stitch-patching with Evolution 3 fabric. When stitch-repairing, treat all stitching with a seam sealer such as K Kote Seam Sealer. Also recommended as an added treatment for stitching repairs are Shoe Goo and Kiwi Shoe Repair (available at K Mart, department, hardware, and sporting goods stores).

NOTE:

Heat applied patches should not be used on Evolution 3 material. Concentrated excessive heat such as that produced by a clothes iron will damage the Evolution fabric.

B. Mildew Removal from Vinyl Areas of Tent Enclosures

1. Open the folding trailer to full height.
2. Extend both bed assemblies and place bed supports onto the appropriate bed pins.
3. Place the canvas support poles into the top assembly tent support brackets and bed bows. Extend support poles until canvas is tight.
4. Secure Evolution 3 around perimeter of bed assemblies with the shock cord.
5. Remove mattress assemblies from unit.
6. Spray X-14 mildew stain remover on a sponge or cloth and apply to interior contaminated areas of bed vinyl material. Allow to air dry. (Mildew will start to fade as the X-14 dries.)

CAUTION:

X-14 is a caustic liquid which can discolor some fabrics and cause deterioration of natural fabrics. Follow directions and cautions on container prior to use. Spray X-14 on sponge or cloth outside the folding trailer. Surfactant within cause Evolution material to leak. Use X-14 in a well ventilated area.

7. Rinse area with a sponge and clean water. Allow to air dry.
8. Apply a generous coating of mildew disinfectant to bed vinyl material to inhibit the return growth of mildew contaminants.

The problem in treating mildew is it varies in degrees of strength. The longer the fungus spreads without treatment, the more impregnated the stains become within the vinyl material. Eventually, without treatment the stains will not clean out, requiring replacement. Therefore, it is imperative that treatment be administered quickly to minimize contamination.

C. Condensation Preventive Maintenance

The relatively small volume and compact construction of a modern recreational vehicle mean that the normal living activities of even a few occupants will lead to rapid moisture saturation of the air contained in the trailer and the appearance of visible moisture, especially in cold weather.

The air inside a recreational vehicle can contain a surprisingly large amount of water vapor. Estimates indicate that a family of four can vaporize up to three gallons of water daily through breathing, cooking, bathing, and washing. Unless this water vapor is carried outside by ventilation, it will condense on the inside of the tent enclosure as moisture.

If you know the signs of excessive moisture and condensation, you can minimize their effects during cold weather by the following:

1. Ventilate with outside air. Partially open one or more windows to provide controlled circulation of outside air into the interior. While this ventilation will increase furnace heating load, it will greatly reduce or eliminate water condensation. Even when it is raining or snowing, ventilation air from outside will be far drier than interior air and will effectively reduce condensation.
2. Provide more ventilation while cooking is being done inside the camper.
3. Try not to camp close to any areas of high humidity such as lakes or ponds.
4. Insure adequate ventilation in areas where condensation problems are experienced.
5. The use of an electric circulating fan or a small dehumidifier inside the camper will noticeably reduce condensation.
6. An application of Rain Check or Camp Dry to the external tent enclosure provides a secondary moisture barrier.

NOTE:

Even when it is raining or snowing, ventilation air from outside will be far drier than interior air and will effectively reduce condensation.

D. Care of the Canvas Tent Material (For Trailers So Equipped)

The canvas on your new trailer is a high quality, ten-ounce duck canvas. Proper care should be given to this material in order to avoid rips, tears, grease, mildew, excessive dirt and soap. Cleaning the canvas is very important. Foreign matter such as tree sap, bird droppings, etc., coming in contact with the exterior surface of the canvas can destroy the water repellency of the material and, in some cases, cause rotting or decay of the canvas. The canvas should be rinsed thoroughly with cool water and allowed to dry completely once it has come in contact with the items mentioned above. In order to remove normal dirt from the canvas, it should be brushed with a dry sponge or soft-bristle brush while dry or after wetting, and following the brushing the canvas should be rinsed with cool water. Sprays are available for renewing the water repellency of the canvas; however, your dealer should be consulted prior to their use.

IMPORTANT:

The canvas should never be stored wet for extended periods of time because it may mildew and lose its strength. If the canvas must be stored wet, set it out to dry as soon as possible.

Should mildew develop on your canvas or vinyl enclosure due to the necessity of closing the unit wet, the mildew can be removed in the following manner:

Mildew Solvent for Canvas Tent Enclosures:

A simple but effective solvent to remove mildew from tents or other canvas-like fabrics can be made using ordinary household items. In about eight ounces of water, dissolve two teaspoons of salt and two teaspoons of concentrated lemon juice. Wash the mildewed cloth with this solution, then rinse with fresh water. Let dry in open air before using.

E. Vinyl Bed End Covers

The vinyl over the bed areas can be cleaned in the same manner as the canvas. When necessary, automobile convertible top cleaners can be used to remove stains.

IMPORTANT:

Follow the manufacturer's instructions carefully for use of such cleaners or damage to the vinyl surface could occur.

CAUTION:

The use of insect repellents, hairsprays, and deodorants inside the folding trailer when sprayed on the tent surfaces will cause a breakdown of the water repellency of the fabric. We suggest, therefore, the very limited use of such sprays inside the unit during camping as damage to the tent enclosure could result.

The zippers on your tent can be lubricated by using a paraffin wax. The use of paraffin on the zippers will enhance their ease of operation around the tent sections and windows.

MISCELLANEOUS STANDARD FEATURES (WILLIAMSBURG MODEL ONLY)

A. Portable Toilet

The portable toilet in your new unit is a high-quality component serviced and warranted by its manufacturer. Please note the specific instructions enclosed with your portable toilet for its use and care. A list of service centers for this component is also provided in the unlikely event of needed service.

OUTSIDE STOVE SET-UP (AMERICANA MODELS) WHERE APPLICABLE

Your Americana model folding trailer is equipped with access to an outside stove. This appliance may be used without setting up the folding trailer, thereby providing cooking convenience during travel without the complete setup of the trailer. In order to hookup and use the outside stove, follow these steps:

- A. Using the access door key unlock the stove storage compartment door.
- B. Lift front locks, grasp the storage tray handle or front retainer and slide the entire unit out until it hits the retaining stops. Be certain the two locks, now at the rear, have re-engaged in the retaining slots.
- C. Lift the stove assembly out of the storage tray and set aside temporarily.
- D. (Sequoia - Brandywine - Shenandoah models only)
Disengage the storage tray from its front retainer by lifting the tray at the rear (see Figures L and M) and slide the tray into the metal glides located directly beneath the stove shelf. Cooking utensils and/or condiments may be conveniently stored in this tray.
- E. Set stove on shelf.

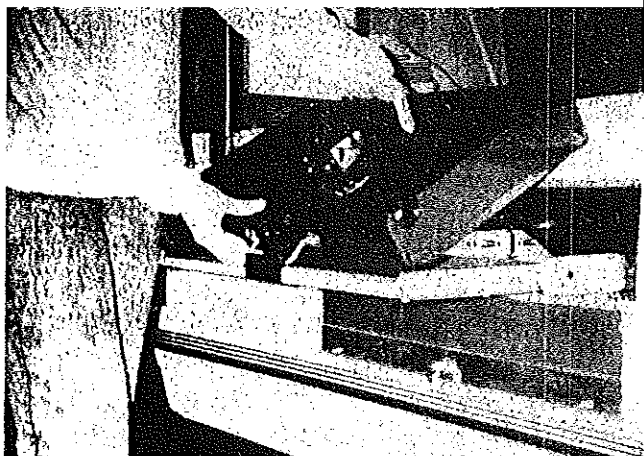

FIGURE L

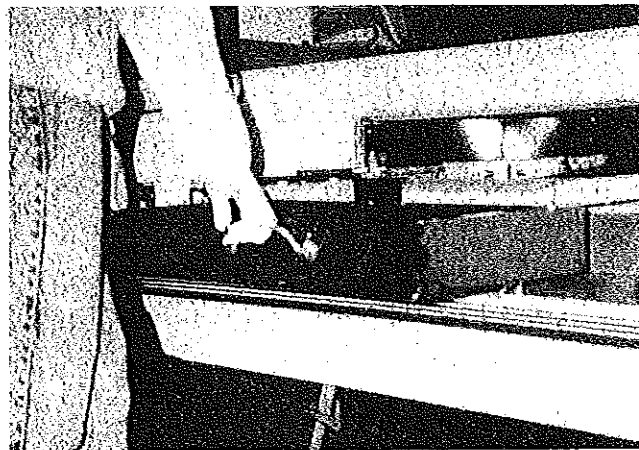

FIGURE M

- F. Attach stove gas line to connection located at bottom flange of right rear panel. (See Figure R)

CAUTION:

Do not use Coleman quick disconnect or Coleman regulator with any stove other than a Coleman propane camp stove. Failure to comply may damage the other stove, may cause gas leaks, and/or may cause other stoves to malfunction.

For additional information on your Coleman camp stove, please refer to the operating instructions received with the stove.

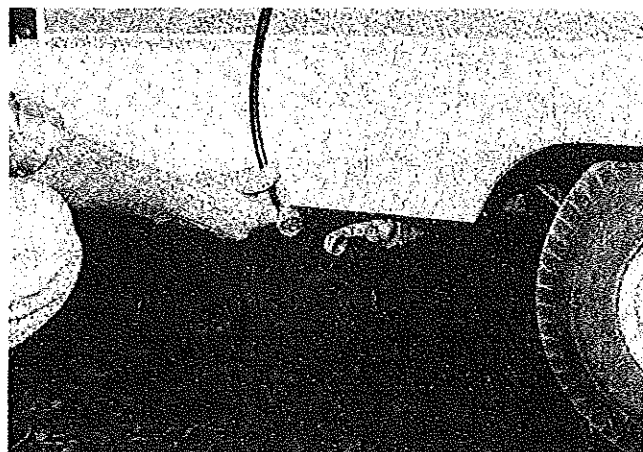

FIGURE N

OUTSIDE STOVE SET UP (PIONEER MODELS)

- A. Remove stove from storage location in lower galley. (See Figure O)
- B. Grasp stove by the webbing strap as shown in Figure P and swing support leg into position.
- C. Using both hands place stove retaining bar on to mounting brackets located on the right rear body rail as shown in Figure Q.
- D. Unsnap the retaining strap on the counter top extension and unfold into position.
- E. Attach gas line from stove to connection located at the bottom flange of right rear panel. (See Figure N)
- F. Open stove cover and secure the splash guards.

CAUTION:

Turn on LP gas and check for leaks with a soapy water solution. Never check with an open flame as fire or explosion will occur.

CAUTION:

Do not check copper and brass plumbing lines and fittings for leaks using ammoniated or chlorinated household type detergents. These can cause cracks to form on the line and brass fittings.

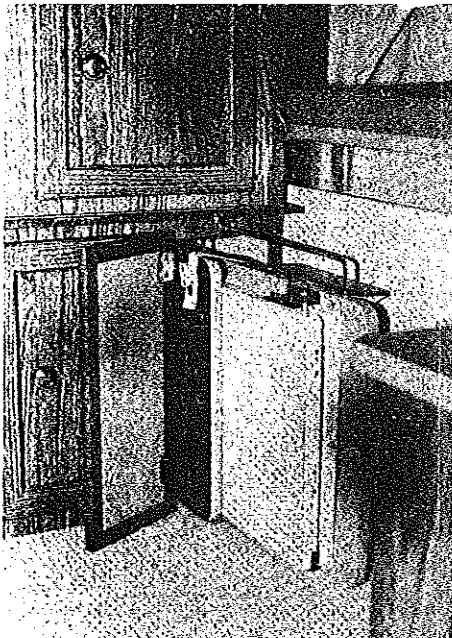

FIGURE O



FIGURE P



FIGURE Q

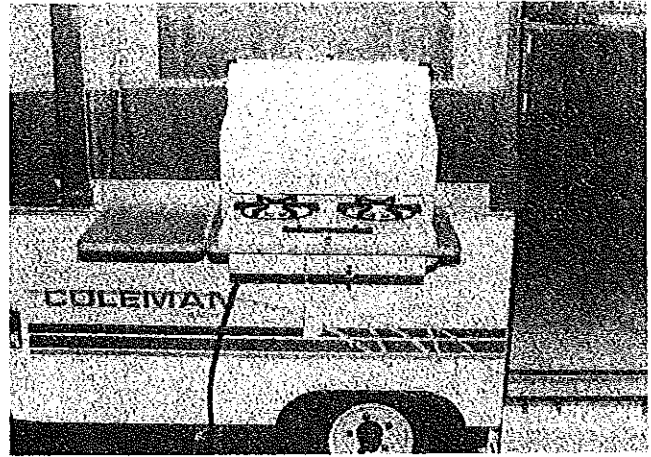

FIGURE R

The outside stove is now ready for use. (See Figure R)

STORING THE STOVE - AMERICANA MODELS

- A. Be certain to turn off the appliance regulator and the burner knobs located on the stove.
- B. Disconnect the gas hose from the outside stove and from the connection located at the bottom of the right rear panel. (Hose can be kept in storage tray.)
- C. Remove stove and set aside.
- D. (Sequoia - Brandywine - Shenandoah models only)
Slide storage tray out of the metal tracks and place on top of the stove shelf. Hook handle on metal tray under front retainer bracket.
- E. Place stove and cooking utensils (depending on choice) in the storage tray and close for travel.

STORING THE STOVE - PIONEER MODELS

- A. Turn off the burner knobs located on the stove.
- B. Disconnect gas line from connection located at the bottom of the right rear panel. Place hose in storage clamp.
- C. Close stove cover and fold counter top extension over and secure with retaining strap.
- D. Return stove to designated storage area located in the lower galley.

CAUTION:

Do not store "hot" stove; allow to cool.

CAUTION:

Do not use stove when trailer is not level or with unreasonable weight of cooking utensils and contents which may cause utensil to slide off stove burner surface.

Do not use stove in tightly closed area. Any combustion process consumes oxygen. Your propane stove must be used with adequate ventilation. Failure to comply may cause asphyxiation. The outside stove is intended for outside use only.

MINI-BLIND OPERATION - (WHERE APPLICABLE)

1. To Release Mini-Blind: Unzip the storage bag to expose mini blind, pull cord and adjusting rod. (See Figure S)
2. To Lower Mini-Blind: Pull straight down on the cord slightly, and move it about 45 degrees to either the left or right and lower the blind. Stop the blind in mid-travel by moving it back to the straight down position. (See Figure T)
3. To Raise Mini-Blind: Pull straight down on cord and release at desired height. It is not necessary to pull the cord to one side or the other to secure blind.
4. To Adjust Mini-Blind: Turn the adjusting rod either direction.
5. To Install Valance: Attach velcro tabs sewn onto back of valance, to the velcro strip applied to the front of the mini-blind storage bag. (See Figure U)
6. To remove the mini-blinds from the mounting brackets (for storage or cleaning).

Locate the mini-blind mounting brackets attached to the interior surface of the top assembly directly above each window side panel.

Lift the mini-blind up and out of the V-shaped portion of the mounting brackets. (See Figure V)

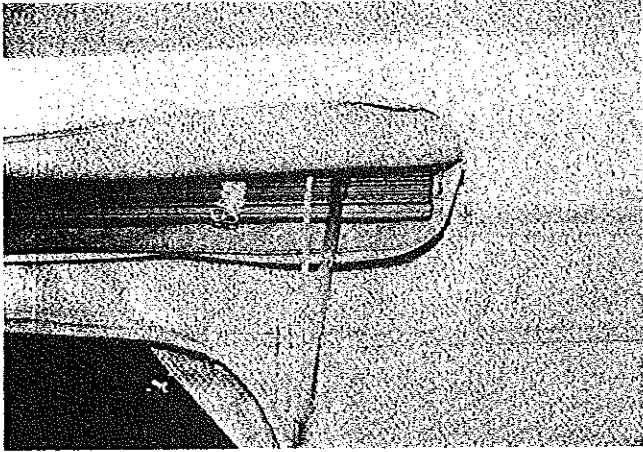

FIGURE S

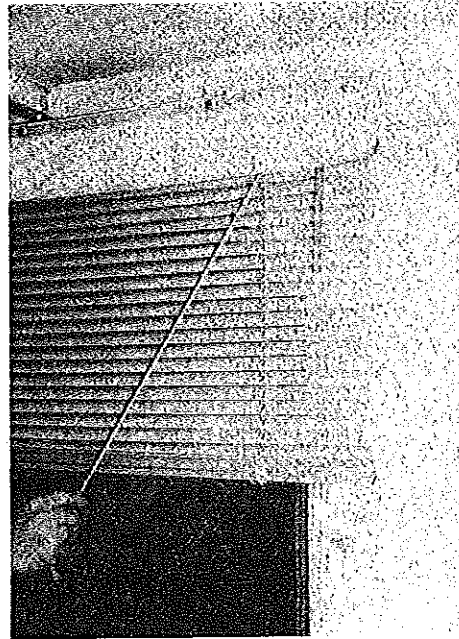

FIGURE T

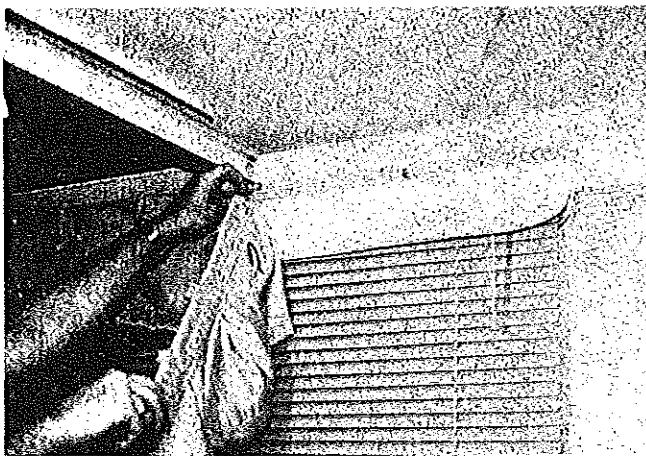

FIGURE U

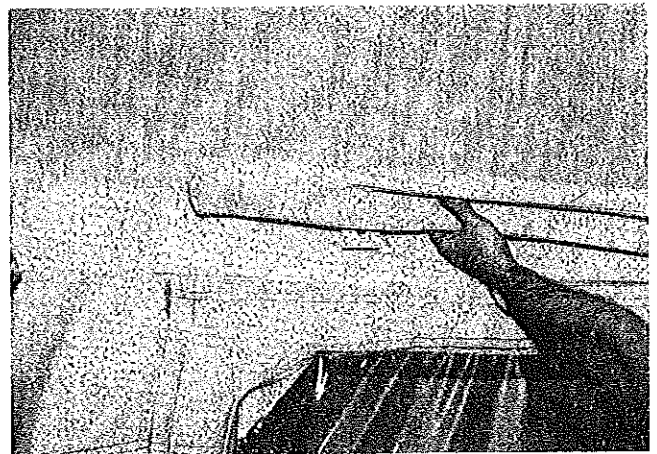

FIGURE V

SPECIFICATIONS

Gross Axle Weight Rating (GAWR) - Weight carrying capacity of the axle while the trailer is in tow. (See certification label.)

Gross Vehicle Weight Rating (GVWR) - The maximum loaded weight the trailer can safely accommodate while in tow. (See certification label).

Cargo Weight - The weight of all additional goods placed in the camping trailer and placed on the trailer hitch while in tow.

Cargo weight or loading capacity can be computed for your model year trailer by securing the weight specification from the trailer certification label (located on the left body panel).

Example:
 GVWR 1,480 lbs.
 Trailer Weight (Dry) 1,000 lbs.
 (curb and hitch)
 Cargo Weight (Dry) 480 lbs.
 (no gas/water in tanks)

To calculate the cargo weight with FULL LP gas bottle and a FULL water tank, these weights must be deducted from the dry cargo weight.

Example:
 LP gas in bottle (1) 20 lbs.
 10 Gallons water* 83 lbs.
 Full tanks 103 lbs.
 Cargo weight dry 480 lbs.
 Less fluid weight 103 lbs.
 Actual cargo weight for transit 377 lbs.
 * Water weighs 8.345 lbs. per gallon.

To insure proper towing characteristics, cargo weight distribution should be as follows: 10% forward and 90% aft of the access door (not to exceed available cargo capacity) distributed evenly throughout the camper.

NOTE:
 Optional accessories added to the trailer must also be deducted from available cargo capacity.

TRAILER MODEL	ROAD HEIGHT	LENGTH CLOSED	LENGTH OPEN	LPG TANK (lbs)	WATER TANK (gallons)	TIRE SIZE LISTED @GVWR	BASE AXLE WEIGHT	BASE HITCH WEIGHT	BASE VEHICLE WEIGHT	CARGO CAPACITY			GROSS AXLE WEIGHT RATE (GAWR)	GROSS HITCH WEIGHT RATE (GHW)	GROSS VEHICAL WEIGHT RATE (GVWR)
										AFT DOOR	FORWARD OF DOOR	TOTAL			
SEDONA	45	11'7"	16'10"	20	10	5.7x8	855	145	1000	345	50	395	1200	195	1395
NEWPORT	47	12'10"	18'11"	20	10	20.5x8x10	1100	110	1210	400	85	485	1500	195	1695
SENECA	47	14'10"	22'8"	20	10	20.5x8x10	1260	140	1400	550	45	605	1810	185	1995
CHESAPEAKE	47	14'10"	22'8"	20	10	20.5x8x10	1240	120	1360	570	65	635	1810	185	1995
ARCADIA	47	14'10"	22'8"	20	10	20.5x8x10	1320	140	1460	490	45	535	1810	185	1995
BRANDYWINE	47	13'8"	19'10"	20	10	20.5x8x10	1250	110	1360	560	75	635	1810	185	1995
GRANDVIEW	47	13'8"	19'2"	20	10	20.5x8x10	1400	125	1525	410	60	470	1810	185	1995
SHENANDOAH	47	13'8"	19'10"	20	10	20.5x8x10	1260	120	1380	550	65	615	1810	185	1995
SEQUOIA	47	15'3"	22'8"	20	10	20.5x8x10	1410	140	1550	400	45	445	1810	185	1995
WILLIAMSBURG	47	15'6"	22'8"	20	20	20.5x8x10	1580	125	1705	420	175	595	2000	300	2300

*With Standard Tires
 Width (all) - 6'8"
 Interior Height (all) - 6'5"
 Coupler Size - 1 7/8" (maximum vertical load 200 lbs., Class 1) - all except Williamsburg
 Coupler Size - 2" (maximum vertical load 350 lbs., Class 2) - Williamsburg
 Electrical System - 115 FAC, 30 AMP
 **Weights listed are subject to a 5% variation due to raw materials.

MAINTENANCE

COMPONENT	IDENTIFICATION	STANDARD CARE	FREQUENCY	AVOID
Appliances				
Stove		Appropriate household cleaners	As needed	Abrasive cleaners
Sink		Appropriate household cleaners	As needed	Abrasive cleaners
Countertops		Clean with warm, soapy water	As needed	Abrasive cleaners
Axle	51" spring center 64" track	U-bolts torqued to 15 - 17 footpounds	Once/season	Road hazards and overloading
Backrest and Cushion covers	Herculon/Olefin	Vacuum; foam-type cleaners	As needed	Grease, oil, excessive heat
Bathtub	ABS plastic	Appropriate cleaners	As needed	Abrasive cleaners
Bearings	Tapered roller	Lubrication See "Tracking System" section	Every 2,000 and before each season	Road hazards and overloading
Bed Slides	Aluminum	Use only silicone lubricant	As needed	Unsupported beds, excessive lubrication
Beds	Blandex	Proper support	Always	Abuse
Brakes	Dexter 7"	Linings and adjustment See brake manual	Before each season and as needed	Overadjustment
Canopy		Vinyl cleaner	As needed	Storing wet for extended periods
Canvas	10 Ounce duck	See "Tent Enclosure" section		Storing wet and harsh detergents
City Water Fill		Cover when not in use	Always	Overtightening
Converter	B&W Manufacturing	Use of proper fuses as noted on converter		Overloading and to repair; sealed unit
Cooler	Coleman	Clean with mild soap and water	As needed	
Coupler	Fulton 1 7/8" (2" on Williamsburg only)	Wheel bearing grease on release lever and socket, proper adjust- ment; See "Tracking System" section	Once per year	Improper adjustment
Dome Light	1.5 amps	Re-lamp only with bulb noted on fixture base	As needed	Lights on when unit is closed; operating in 12 VDC mode
Drain (Sink)		Winterize on units with swing-level galley	As needed	Freezing
Drain (Tub)		Winterize with proper antifreeze	As needed	Freezing
Drapes		Hand washable; mild detergent; drip dry	As needed	Machine washing; storing wet

MAINTENANCE

COMPONENT	IDENTIFICATION	STANDARD CARE	FREQUENCY	AVOID
Evolution 3		See "Tent Enclosure" section		
Exterior Finish				
Metal Panel	Krystal Kote	Wash with water and apply quality auto wax	As needed	Abrasive cleaners; waxing in the hot sun
ABS Panel	ABS plastic	Mild soapy water and wax	As needed	
Fire Extinguisher		Check for charge prior to each camping trip; note directions on extinguisher		
Floor Covering	Armstrong vinyl	Clean with water and mild soap	As needed	Abrasive cleaners
Frame	Painted steel	Rinse with water after salt or chemical contact; touch up bare spots	As needed	Chemical contact
Furnace	12,000 BTU Hydro Flame 20,000 BTU Hydro Flame	See furnace manual		
Gas Bottle		See "Gas System" section		
Gas Hose	Rubber	See "Gas System" section		
Gas Line	Copper	See "Gas System" section		
Lift Assemblies	Stainless steel	See "Lift System" section		
Lug Bolts/Nuts	13/16"	70 Footpounds for 8" 85 Footpounds for 10"	Before each trip	
Mattress Covers	Herculon/Olefin	Vacuum; foam-type cleaners	As needed	Grease, oil, excessive heat
Outside stove		Warm soapy solution for cleaning; do not leave open without brace in position; do not leave unattended		Leaving unattended; applying excessive weight to shelf
Pigtail	Bargman	Inspect for cuts, breaks, or dirt	Prior to each use	Cutting, dirt
Pulleys		See "Lift System" section		
Pump (Electric)	Shurflo	See separate manual with trailer		Operating w/empty tank; clogged filter
Pump (Hand)	Leisure Components	Lubricate pump lever with mineral oil	Once a year	Freezing with water in line
Ratchet		See "Lift System" section		
Screen Door	Aluminum	Wash with water and apply quality auto wax	As needed	Abrasive cleaners

MAINTENANCE

COMPONENT	IDENTIFICATION	STANDARD CARE	FREQUENCY	AVOID
Stabilizer	Atwood (650 lbs)	Keep free of dirt; lubricate with silicone	As needed	Dirt buildup
Swing-level Galley	Americana series only	Silicone lubricate and proper adjustment	As needed	Overloading, dropping or lifting in areas other than indicated
Table	5/8" Particle board	Clean with damp cloth	As needed	Direct heat; excessive exposure to elements
Tires	Duro	See "Tracking System" section		Under- or over- inflation
Tongue Jack	Atwood (500 lbs.)	Position handle properly while traveling; lubricate with light oil	Once a year	Salt and chemical contact
Top Assembly Exterior	Aluminum sandwich panel	Wash as needed; inspect for voids in caulking	Check caulking once per season	Abrasive cleaners; excessive weight
Interior	Vinyl luan	Clean with water and mild soap solution	As needed	Abrasive and sharp instruments
Vinyl Windows	Clear vinyl	Warm water and mild detergent	As needed	Abrasives and storing wet
Water Heater	Atwood (6 gallon)	See "Water System" section		
Water Tank	Polyethylene	See "Water System" section		
Wheel Covers	Plastic	Warm water and mild detergent	As needed	Excessive prying or impact

LIMITED WARRANTY

1992 FLEETWOOD FOLDING TRAILER

1. Your new Fleetwood folding trailer is warranted to the original retail consumer for one year from the date of retail purchase to be free from defects in material and workmanship. This warranty is not transferrable.

2A. The lift system (used to raise and lower the roof) is warranted to the original retail consumer for his or her lifetime against functional defects in material and workmanship. This warranty covers parts and labor for the first three years and parts only thereafter with the following exclusions:

i. Normal adjustments to the lift system (such as periodic roof height adjustment to compensate for stretch in cables) are covered for the first year of this warranty only.

ii. The installation of a roof air conditioner and/or any other roof-mounted accessories cannot exceed 150 pounds. Exceeding this limit voids the warranty provision on the lift system.

iii. Normal use, wear and tear, and excessive exposure to the elements.

iv. Any damage resulting from alterations to the lift system.

v. Any damage caused by improper routine maintenance or improper repair or by use of improper repair parts.

2B. The floor is warranted to the original retail consumer for his or her lifetime against functional defects in material and workmanship. The warranty on the vinyl floor covering is found in section 7.8 of this warranty. Parts and labor under this paragraph are covered for the first three years; parts only are covered thereafter.

2C. The steel frame is warranted to the original retail consumer for his or her lifetime against functional defects in material and workmanship. This lifetime provision does not include the surface finish of the frame. Parts and labor under this paragraph are covered for the first three years; parts only are covered thereafter.

2D. The roof of this folding trailer is warranted to the original retail consumer for five years from the date of retail purchase against functional defects in material or workmanship. Parts and labor under this paragraph are covered for the first three years; parts only are covered for the fourth and fifth years.

2E. The Evolution 3 tent is warranted to the original retail consumer for three years from the date of purchase against functional defects. During year one, parts, labor, and freight are covered. During year two, parts and freight only are covered; labor charges are not. During year three, parts are warranted at 50% of retail price; freight and labor charges are not included. The tent is not warranted against fading, discoloration, soiling, leaking due to contaminants, or problems resulting from misuse or abuse.

2F. The warranty of paragraphs 2A through 2D is not transferrable and is limited to functional defects.

3. Return within ten days of retail purchase of the warranty registration form provided with the folding trailer is a requirement to obtain warranty performance. The Warranty Registration Form will also permit Fleetwood to locate consumers in the unlikely event of a product safety recall. Fleetwood will send the customer an owner's card that reflects the warranty data for the trailer.

4. During the specified times, any defective parts in a Fleetwood folding trailer will, at Fleetwood's option, be either repaired or replaced on an exchange basis with new or reconditioned parts. This Warranty does not cover the expense to take the folding trailer to the dealer for repair, nor the return expense. The consumer must pay all expenses incurred in obtaining warranty performance other than those specifically provided for in this Warranty.

5. The date of retail sale is established by the Warranty Registration. Replacement parts are warranted for the unexpired duration of the original warranty.

6. To obtain warranty performance:

6.1 Consult the yellow pages of the telephone book under "Trailers - Camping and Travel" for the name, address, and telephone number of the nearest authorized Fleetwood folding trailer dealer; or call Fleetwood Folding Trailers, Inc. at 814/445-9661. (Collect calls will not be accepted.) Call the authorized Fleetwood folding trailer dealer, report the problem and schedule an appointment. Take the trailer at the scheduled time to the dealer along with the owner's card sent to you by Fleetwood. Only authorized Fleetwood folding trailer dealers may perform warranty obligations.

6.2 The authorized Fleetwood folding trailer dealer will advise when the warranty performance has been completed. All payments for warranty service and for parts will be made by Fleetwood to the dealer and not to the consumer.

General Exceptions and Exclusions

7. To the extent any or all of the following exclusions or provisions of this warranty are prohibited by any federal, state, or municipal law which cannot be preempted, those exclusions or provisions shall not be applicable.

7.1 THERE ARE NO OTHER EXPRESS WARRANTIES EXCEPT AS SET OUT ABOVE AND ANY IMPLIED WARRANTIES, INCLUDING THE IMPLIED WARRANTIES OF MERCHANTABILITY AND FITNESS FOR A PARTICULAR PURPOSE, ARE LIMITED IN DURATION TO THAT OF THE EXPRESS WARRANTY. Some states do not allow limitations on how long an implied warranty lasts, so the above limitation may not apply to you.

7.2 THIS WARRANTY DOES NOT COVER CONSEQUENTIAL DAMAGES, INCIDENTAL DAMAGES, OR INCIDENTAL EXPENSES, INCLUDING DAMAGE TO PROPERTY. Some states do not allow the exclusion or limitation of incidental or consequential damages, so the above limitation or exclusion may not apply to you.

7.3 This warranty does not cover damages caused by failure to perform normal and routine maintenance as set out in the folding trailer owner's manual.

7.4 This warranty does not cover damage caused by mishandling, neglect, abuse, misuse, lightning, or corrosive atmospheres.

7.5 This warranty shall not apply if the serial number plate is removed or defaced.

7.6 The tent material is not warranted against fading, discoloration, soiling, or problems resulting from misuse or abuse. Ripped or torn tents will be repaired or replaced at Fleetwood's sole discretion through an authorized Fleetwood folding trailer dealer, provided the rips or tears are noted prior to retail delivery.

7.7 Top assemblies are warranted only for functional defects such as leaks. Any nonfunctional or cosmetic problems that are not noted prior to retail delivery are not covered by this warranty.

7.8 The vinyl floor covering is warranted for gouges, cuts, or tears only if noted prior to retail delivery. Such damage noted prior to delivery shall be remedied by repair or replacement at Fleetwood's sole discretion.

7.9 The lightbulbs, fuses, tire valve cores, and other similar items are not covered by this warranty and are sold AS IS.

7.10 The tires, water heater, electric water pump, porta potti, furnace, and refrigerator in trailers so equipped are warranted by their respective manufacturers. A copy of the warranty for each of these components is provided with the folding trailer.

7.11 Trailers used for rental purposes are covered by this warranty for three (3) months from the date of purchase by the rental dealer; or if rented by an authorized Fleetwood folding trailer dealer, from the date of rental registration.

7.12 This warranty applies only to products sold at retail in the United States and Canada.

8. This warranty does not cover extra expenses such as transportation to and from the dealer or manufacturing plant location, loss of time, loss of pay, loss of use of the folding trailer, inconvenience, commercial loss, towing charges, bus fares, vehicle rental, incidental charges such as telephone calls or lodging bills, or other incidental or consequential damages (other than injury to the person).

9. Fleetwood Folding Trailers, Inc. reserves the right to make changes in the design or material of its products without incurring any obligation to incorporate such changes in any product previously manufactured.

10. This warranty gives you specific legal rights, and you may also have other rights which vary from state to state.

REPORTING SAFETY DEFECTS

If you believe that your vehicle has a defect which could cause a crash or could cause injury or death, you should immediately inform the National Highway Traffic Safety Administration (NHTSA) in addition to notifying Fleetwood Folding Trailers, Inc.

If NHTSA receives similar complaints, it may open an investigation; and if it finds that a safety defect exists in a group of vehicles, it may order a recall and remedy campaign. However, NHTSA cannot become involved in individual problems between you, your dealer, or Fleetwood Folding Trailers, Inc.

To contact NHTSA, you may either call the Auto Safety Hotline toll free at 800/424-9393 (or 366-0123 in Washington, DC area) or write to NHTSA, U.S. Department of Transportation, Washington, DC 20590. You can also obtain other information about motor vehicle safety from the Hotline.

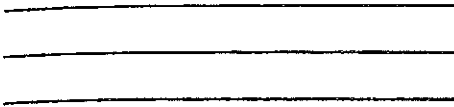

NO POSTAGE
NECESSARY
IF MAILED
IN THE
UNITED STATES

BUSINESS REPLY MAIL
FIRST CLASS PERMIT NO. 83 SOMERSET, PA 15501

POSTAGE WILL BE PAID BY ADDRESSEE

FLEETWOOD FOLDING TRAILERS, INC.
ATTN: WARRANTY SERVICE DEPT.
POST OFFICE BOX 111
SOMERSET, PA 15501-9985

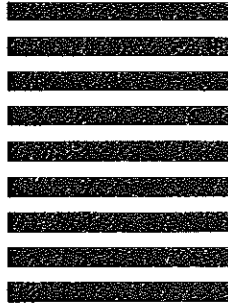

CHANGE OF OWNERSHIP NOTIFICATION

MODEL INFORMATION

YR. _____ MODEL _____

SERIAL NUMBER _____

NEW OWNER INFORMATION

PURCHASE
DATE _____

NAME _____

ADDRESS _____

CITY _____

STATE/PROVINCE _____ ZIP _____

PREVIOUS OWNER INFORMATION

PURCHASE
DATE _____

NAME _____

ADDRESS _____

CITY _____

STATE/PROVINCE _____ ZIP _____

NOTE:

This card is to be completed and sent to Fleetwood Folding Trailers, Inc. ONLY after the original retail purchaser transfers ownership of the trailer to another party.

NOTICE TO DEALER AND CONSUMER

Because brake requirements are governed by state or provincial regulation, the requirements vary from state to state. To insure compliance with applicable regulations, we recommend you check with your Department of Motor Vehicles to determine if brakes are required on your trailer. The weight specifications in the owner's manual will assist you in making this determination. Available through your dealer is an accessory electric brake package which can be installed on your trailer without any problem.

1968C337 5/91

Printed in U.S.A.

