



## Bench Top Water Filter

# INSTALLATION INSTRUCTIONS



## ENJOY THE BENEFITS OF FRESH, HEALTHY FILTERED WATER

Thank you for purchasing a Pure Water Systems Bench Top Water Filter. This filter does not require a plumber for installation and therefore is completely portable. The Bench Top Water Filter connects directly to your existing cold water tap and can be installed in just 3 easy steps:

**STEP 1.** Fitting the cartridge. **STEP 2.** Attaching the diverter. **STEP 3.** Flushing the cartridge.

This product is very easy to install and fits almost any standard kitchen tap. However, if you require any assistance, please contact our Customer Service Department on **1300 808 966**.

# INSTALLING YOUR BENCH TOP WATER FILTER AND CARTRIDGE



← For an easy to follow video on how to install your **Bench Top Water Filter** and **Hi-Tech Optimiser Cartridge** for **town water**, please scan QR code.

Please refer to page 2 for installation of the **Doulton Ceramic Cartridges** for **tank water** use.



## STEP 1. FITTING THE CARTRIDGE

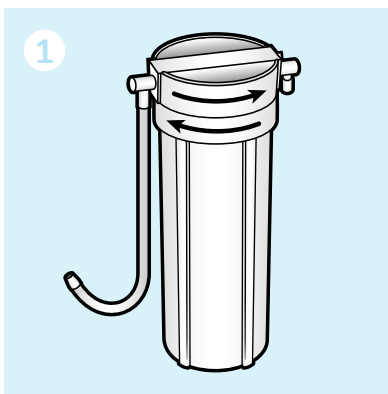

1. Turn the system upside down and unscrew the housing from the base.
2. With the main housing upside down, check the black o-ring is seated in correctly by pressing down on the seal all the way around.
3. Remove the wrapper and label from the new filter cartridge.
4. Firmly press down on the rubber seals all the way around on both ends of the filter cartridge to ensure they are seated correctly.
5. Place the cartridge inside the housing.
6. With the system still upside down, screw the cap back onto the housing.

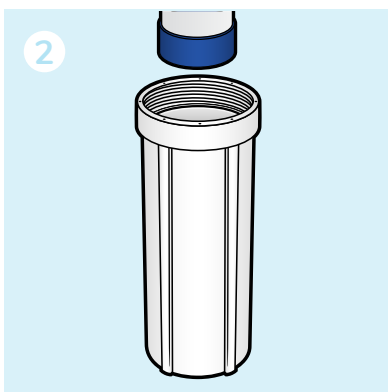

## STEP 2. FITTING THE TAP ADAPTOR

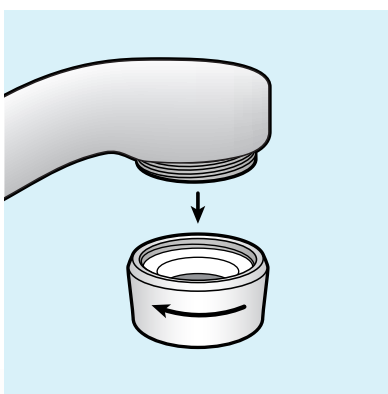

**The style of tap you have will determine which of the 3 tap adaptors supplied will be required to attach the diverter to your faucet.**

1. The diverter needs to be fitted to the bottom of your kitchen tap. Remove the aerator to find out if you have an **internal**, **external** or **no thread** on your tap. If the supplied tap adaptors do not fit, please contact our Customer Service Department for assistance with alternative connection options.

Refer to **Tap Adaptor Options** on page 3.

Continued on page 3.



# INSTALLING YOUR BENCH TOP WATER FILTER AND CARTRIDGE



← For an easy to follow video on how to install your **Bench Top Water Filter** and **Ceramic Cartridges** for **tank water** use, please scan QR code.

Please refer to the previous page for installation of the **Hi-Tech Optimiser Cartridge** for **town water** use.

## STEP 1. FITTING THE CARTRIDGE

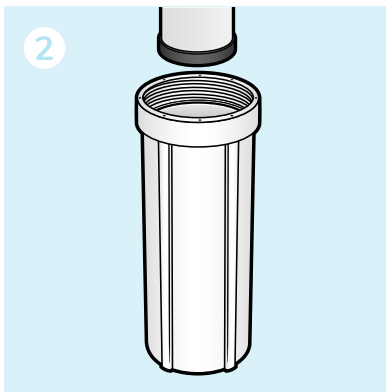
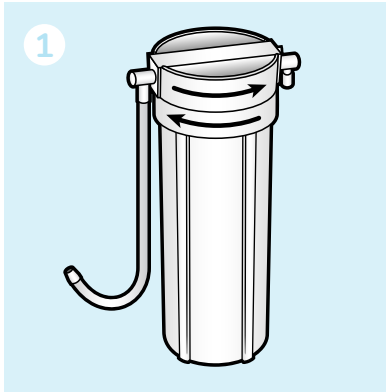

1. Turn the system upside down and unscrew the housing from the base.
2. With the main housing upside down, check the black o-ring is seated in correctly by pressing down on the seal all the way around.
3. Carefully remove the wrapper and label from new filter cartridge. Try to only handle the cartridge by the plastic end caps.
4. Firmly press down on the rubber seals all the way around on both ends of the filter cartridge to ensure they are seated correctly.
5. Place the cartridge inside the housing.  
**NOTE: The end of the cartridge with the white writing should be placed into the housing facing up.**
6. With the system still upside down, screw the cap back onto the housing.

## STEP 2. FITTING THE TAP ADAPTOR

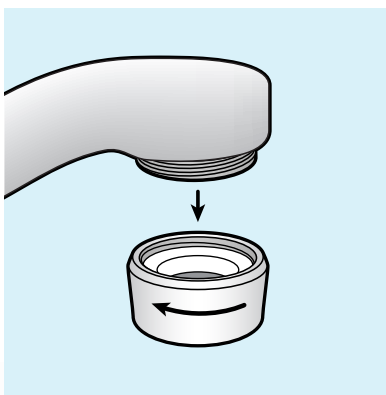

**The style of tap you have will determine which of the 3 tap adaptors supplied will be required to attach the diverter to your faucet.**

1. The diverter needs to be fitted to the bottom of your kitchen tap. Remove the aerator to find out if you have an **internal, external** or **no thread** on your tap. If the supplied tap adaptors do not fit, please contact our Customer Service Department for assistance with alternative connection options.

Continued on the following page.



## STEP 2. Continued

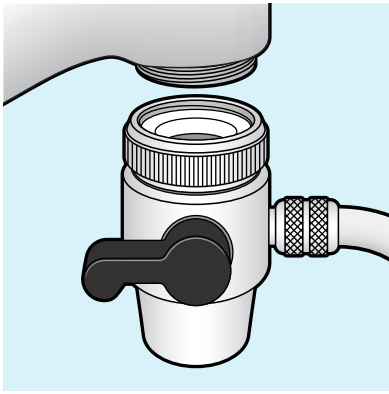

### A. External Threaded Tap

1. The washer comes pre-installed into the top of the diverter valve. Ensure that it is seated correctly.
2. Screw the diverter straight up onto the end of the tap.
3. Complete the installation process (**See step 3**).  
If the diameter of the tap is too big to fit the diverter, please go to installation D.

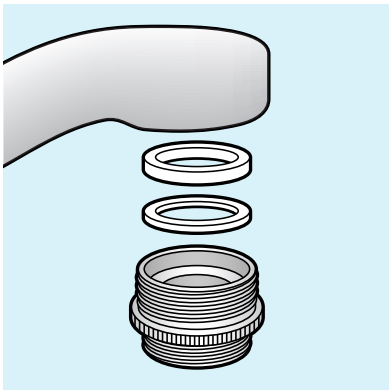

### B. Internal Threaded Tap (TA1 Adaptor)

1. Place the rubber washers into the TA1 tap adaptor (thin first, then the thicker washer).
2. Screw the tap adaptor up into the inside of the tap and tighten.
3. Attach the diverter to the bottom of the tap adaptor.
4. Complete the installation process (**See step 3**).

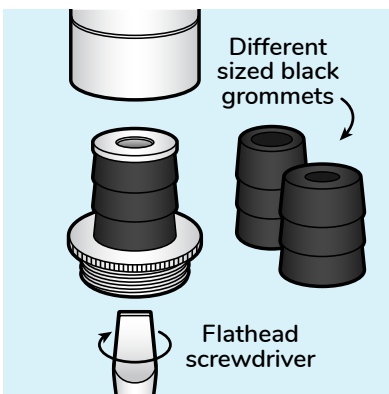

### C. No Thread - Small Tap Diameter (TA2 Adaptor)

1. Select the correct sized black grommet to fit on the TA2 internal tap adaptor which will then go up into the inside of the tap (there are 3 different sized black grommets that can be used for different sized taps).
2. Push the black end of the adaptor up inside of the tap.
3. Using a flathead screwdriver on the silver plate, tighten clockwise (this is a reverse thread) until the black grommet widens and holds firmly to the inside of the tap.
4. Attach the diverter to the bottom of the tap adaptor.
5. Complete the installation process (**See step 3**).

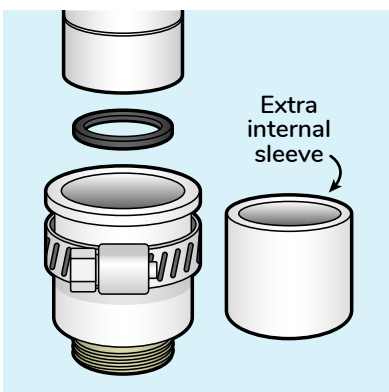

### D. No Thread - Large Tap Diameter (TA3 Adaptor)

1. The TA3 tap adaptor comes with an extra small internal sleeve which can be removed for larger taps.
2. Push the black washer into the inside of the TA3 tap adaptor.
3. Push the tap adaptor up and over the outside of your tap as far as possible.
4. Slip the steel clamp over the white rubber adaptor as high as possible on the adaptor to avoid splitting.
5. Using a screwdriver, tighten the clamp firmly.
6. Attach the diverter to the bottom of the tap adaptor.
7. Complete the installation process (**See step 3**).



## STEP 2. Continued

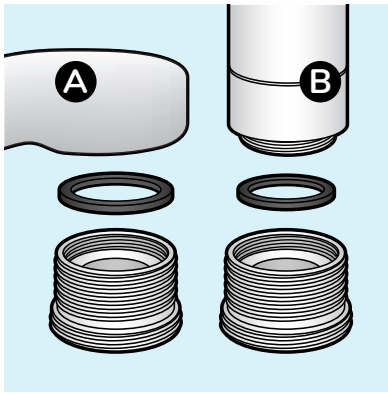

### E. Internal/External Threaded Tap (TA4 Adaptor)

1. This adaptor fits both internal and external small tap diameters:  
**A. Internal thread:** Place the existing rubber washer from the aerator back inside the tap and screw the TA4 adaptor onto the tap and tighten.  
**B. External thread:** Place the supplied rubber washer inside the TA4 tap adaptor and screw the adaptor to the tap and tighten.
2. Attach the diverter to the bottom of the tap adaptor.
3. Complete the installation process (**See step 3**).

**Note:** The TA4 is not supplied as standard. Please contact our Customer Service Department on 1300 808 966 should you require a TA4 to be sent out.

## STEP 3. FLUSHING THE CARTRIDGE

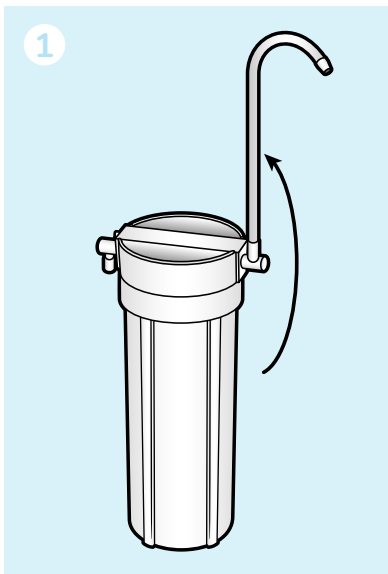

1. With the system upside down, raise the spout half a turn anticlockwise as per **Figure 1** and ensure the spout is positioned over the sink.
2. Turn on the cold water tap and turn the diverter lever up to the horizontal position and run water through the system for a few minutes. (New filters need to be flushed for a few minutes prior to being used. You may notice that the initial flow of water is discoloured or black, this is residual carbon fines left behind from the manufacturing process).
3. Return spout and system to its upright position **Figure 2** and repeat Step 2.
4. Your system is now ready for use.

Note: As well as periodic cleaning, cartridges should also be replaced every **12 months / 2,300 litres for the Doulton Ceramic Cartridge** and **12 months / 1,892 litres for the Hi-Tech Optimiser Cartridge**, whichever comes first, to avoid a build-up of potentially harmful bacteria.

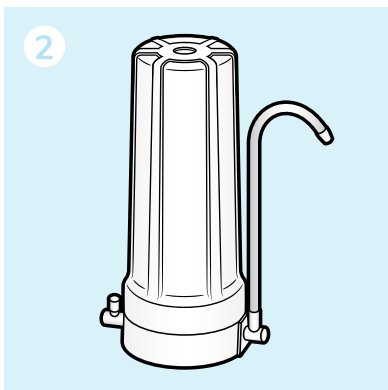

### Important things to remember

- When you first install your filter or replacement cartridge you may experience intermittent dripping due to pressure building up, this will cease with use. If this persists repeat Step 3.
- Do not run hot water through the system as this may damage the cartridge.
- Air bubbles may be present or the water may seem cloudy for a short period. This will cease with use.
- The fresh, healthy water from your filter is not just for drinking; it can be used for many things such as making tea and coffee, cooking veggies and pasta, even water for your pets and plants.



# CLEANING INSTRUCTIONS: CERAMIC CARTRIDGE

Water flow from the cartridge may reduce over time due to a build-up of filtration particulate contaminants (e.g. dirt, sediment, algae, rust). To return the flow to its normal level simply remove, clean and replace the filter cartridge as follows:

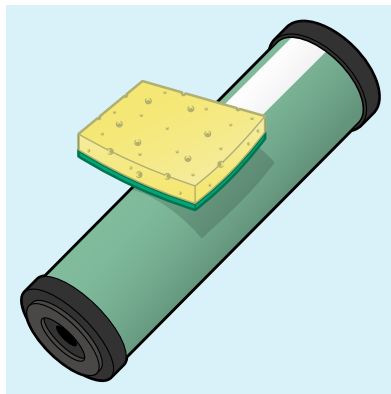

## STEP 1. Removing and cleaning the filter cartridge

1. Unscrew the filter housing from the base and remove the ceramic cartridge from the filter housing.
2. Take the cartridge to the sink and hold the cartridge under running water, taking care at all times not to contaminate the inside of the filter cartridge with either unfiltered water or dirty hands.
3. Scrape 0.5 to 1mm off the outer surface with a kitchen scourer.
4. Clean the inside of the housing with a food-grade sterilising solution or white vinegar. Rinse the housing well afterwards.
5. Place the filter cartridge inside the housing. Ensure the open end of the filter cartridge with white writing is facing UP and towards you (the filter cartridge can only be installed one way). Make sure the rubber seals on both ends of the filter cartridge are seated correctly.
6. Ensure that the black o-ring is properly seated in the groove of the housing base. With the system still upside down, screw the base back onto the housing.

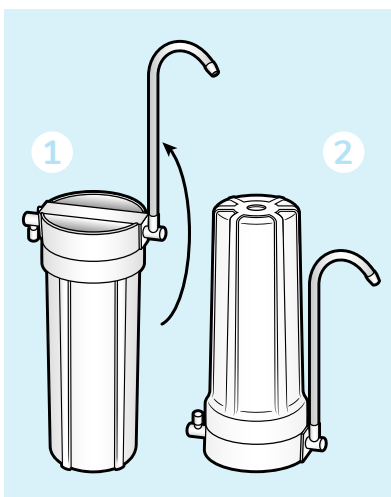

## STEP 2. Flush the cartridge

1. With the system still upside down, raise the spout half a turn as per **Figure 1** - ensure the spout is positioned over the sink.
2. Turn on the cold water tap and turn the diverter lever on your faucet up to the horizontal position. Run water through the system for a few minutes.
3. Return the spout and system to its upright position **Figure 2**.
4. Your system is now ready for use.

Note: As well as periodic cleaning, the cartridge should also be replaced every 12 months / 2,300 litres, whichever comes first, to avoid a build-up of potentially harmful bacteria.







Pure Water Systems (Aust.) Pty Ltd  
27 Leda Drive | PO Box 685, Burleigh Heads QLD 4220

ABN: 19 051 617 031

Plumbing Licence No: QBCC Act Licence No. **15359903** | NSW Licence No. **337690C**

☎ 1300 808 966 | 📠 (07) 5520 0056

✉ info@purewatersystems.com.au | 🌐 purewatersystems.com.au