

CARTRIDGE REPLACEMENT: GENERIC



← For an easy to follow video on how to replace your filter cartridge, please scan here.



STEP 1. Replace the filter cartridge

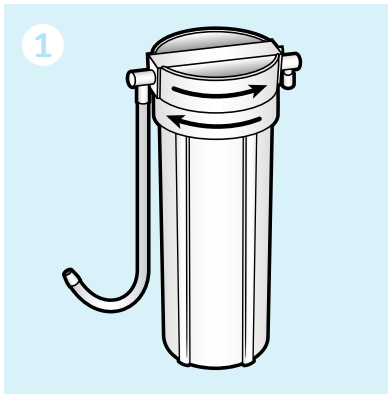

Turn the system upside down and place over a sink, unscrew the base from the housing.

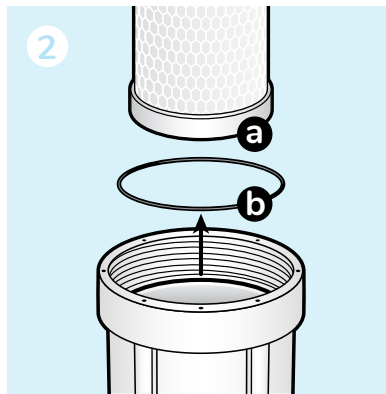

Remove the old filter cartridge (a) and o-ring (b). Discard both.

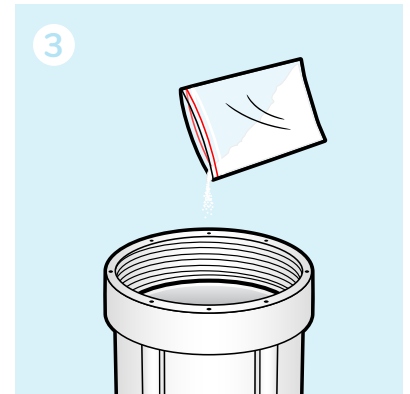

Clean the inside of the housing and base using a food-grade sterilising solution (provided with replacement cartridge). Thoroughly rinse the housing and base with clean water.

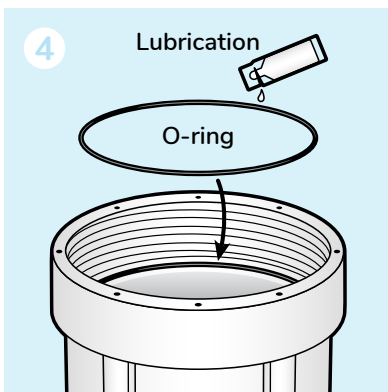

Lubricate the new o-ring with the solution provided, then seat the o-ring in the groove of the housing, as per the instructions supplied. Ensure the o-ring is seated properly.

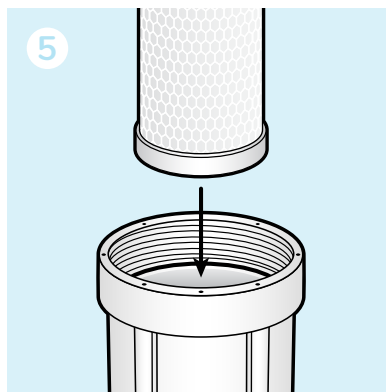

Remove the wrapper and label from the new cartridge. **Ensure the rubber seals on both ends of the cartridge are seated correctly**, then place the cartridge inside the housing.

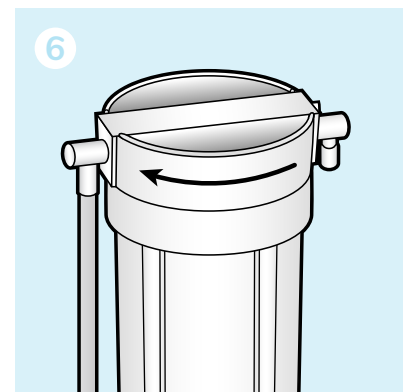

With the system still upside down, screw the base back onto the housing.



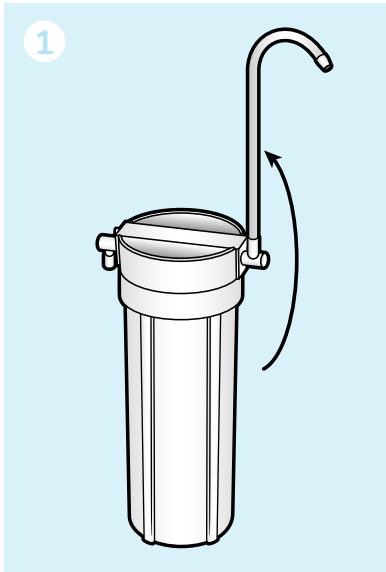

STEP 2. Flush the cartridge

1. With the system still upside down, raise the spout half a turn anticlockwise as per **Figure 1** - ensure the spout is positioned over the sink.
2. Turn on the cold water tap and turn the lever on your diverter up to the horizontal position. Run water through the system for a few minutes. (New filters need to be flushed for a few minutes prior to being used. Depending on the type of cartridge you are using, you may notice the initial flow of water is discoloured or black. This is residual carbon fines left behind from the manufacturing process).

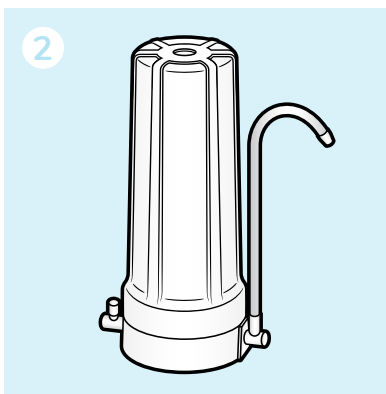

3. Turn off the tap and return the system and spout to its upright position **Figure 2**.
4. Once again, ensuring the spout is over the sink, run water through the system for a few minutes.
5. Your system is now ready for use.

To ensure you're drinking the best quality water and avoid potential bacteria build-up, it is recommended to replace your filter cartridge every 12 months or once the recommended litre usage has been reached, whichever comes first.

The cartridge replacement process is simple to complete in just a few easy steps. Should you need any assistance, please contact our Customer Service Department on **1300 808 966**.

Important things to remember

- When you first install your filter or replacement cartridge you may experience intermittent dripping due to pressure building up, this will cease with use. If this persists repeat Step 2.
- Do not run hot water through the system as this may damage the cartridge.
- Air bubbles may be present or the water may seem cloudy for a short period. This will cease with use.
- The fresh, healthy water from your filter is not just for drinking; it can be used for many things such as making tea and coffee, cooking veggies and pasta, or even water for your pets and plants.

