



Référence: E13*122R00/04*0192*00

Annexes: - Rapport technique
- Fiche de renseignements du constructeur

Luxembourg, le 04 février 2019

COMMUNICATION COMMUNICATION

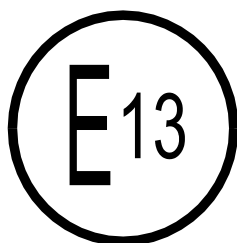

concernant ⁽²⁾:
concerning ⁽²⁾:

- DELIVRANCE D'UNE HOMOLOGATION
APPROVAL GRANTED
- ~~EXTENSION D'HOMOLOGATION~~
~~APPROVAL EXTENDED~~
- ~~REFUS D'HOMOLOGATION~~
~~APPROVAL REFUSED~~
- ~~RETRAIT D'HOMOLOGATION~~
~~APPROVAL WITHDRAWN~~
- ~~ARRET DEFINITIF DE LA PRODUCTION~~
~~PRODUCTION DEFINITELY DISCONTINUED~~

d'un élément constitutif conformément au Règlement N° 122
of a component type pursuant to Regulation N° 122

Numéro d'homologation:

Approval number:

E13*122R00/04*0192*00

Raison de l'extension:

Reason for extension:

not applicable

Marque d'homologation:

Approval mark:

 122R - 000192

SECTION I SECTION I

GÉNÉRALITÉS:

GENERAL:

1.1. Marque (raison sociale du constructeur):

Make (trade name of manufacturer):

(see information document)

1.2. Type:

Type:

FJH

Variante(s):

Variant(s):

FJH-2/1C, FJH-2.2/1C, FJH-4/1C, FJH-5/1C

- 1.3. Moyens d'identification du type s'il est indiqué sur l'élément constitutif ^(b):**
Means of identification of type, if marked on the device ^(b): FJH-2/1C, FJH-2.2/1C, FJH-4/1C, FJH-5/1C
- 1.3.1. Emplacement de cette marque:**
Location of that marking: Printed on a label which is affixed on the housing of the heater
- 1.4. Nom et adresse du constructeur:**
Name and address of manufacturer: Harbin Haoke Science and Technology Co., Ltd.
No.9, Xingnan Road, Nangang District,
Harbin City, Heilongjiang, Province,
P.R. China
- 1.5. Emplacement de la marque d'homologation CEE:**
Location of the ECE approval mark: Printed on the data plate of the combustion heater
- 1.6. Adresse de l'atelier (des ateliers) de montage:**
Address(es) of assembly plant(s): Harbin Haoke Science and Technology Co., Ltd.
No.9, Xingnan Road, Nangang District,
Harbin City, Heilongjiang, Province,
P.R. China

SECTION II
SECTION II

- | | | |
|-----------|--|---|
| 1. | Renseignements supplémentaires (le cas échéant):
Additional information (where applicable): | not applicable |
| 2. | Autorité déléguée:
Assigned authority: | <i>Société Nationale de Certification et d'Homologation
L-5201 Sandweiler</i> |
| | Service technique chargé des essais:
Technical service responsible for carrying out the tests: | TÜV Rheinland Luxemburg GmbH
2a, Kalchesbruck
L-1852 Luxembourg |
| 3. | Date du procès-verbal d'essai:
Date of test report: | 08.01.2019 |
| 4. | Numéro du procès-verbal d'essai:
Number of test report: | 88-R122-031/19-00 |
| 5. | Remarques (éventuelles):
Remarks (if any): | not applicable |
| 6. | Lieu:
Place: | Luxembourg |
| 7. | Date:
Date: | 04 février 2019 |
| 8. | Signature:
Signature: | |

**Pour le Ministre de la Mobilité
et des Travaux publics**



Alain DISIVISCOUR
Conseiller

Pour la SNCH

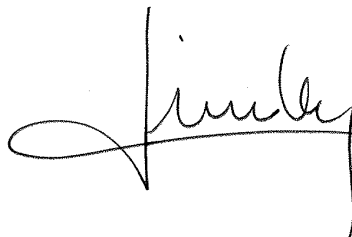
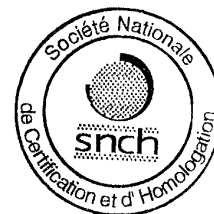
Laurent LINDEN
Attaché de Direction



- 9. On trouvera ci-joint le numéro de référence du dossier d'homologation remis à l'autorité chargée de l'homologation, qui peut être obtenu sur demande.**
The index to the information package lodged with the approval authority, which may be obtained on request, is attached. see: INDEX to TYPE-APPROVAL REPORT

⁽²⁾ **Biffer les mentions qui ne conviennent pas.**

Strike out what does not apply.

^(b) **Si les moyens d'identification du type contiennent des caractères impropres pour la description du véhicule, de l'élément constitutif ou de l'entité technique faisant l'objet de la présente fiche de renseignements, ces caractères doivent être représentés dans la documentation par le symbole: „?“ (par exemple ABC??123??).**

If the means of identification of type contains characters not relevant to describe the vehicle, component or separate technical unit types covered in this information document, such characters shall be represented in the documentation by the symbol „?“ (e.g. ABC??123??).



Référence: E13*122R00/04*0192*00

Annexes: - Rapport technique
- Fiche de renseignements du constructeur

Luxembourg, le 04 février 2019

INDEX DU DOSSIER D'HOMOLOGATION INDEX TO TYPE-APPROVAL REPORT

	Numéro d'homologation: Approval number:	E13*122R00/04*0192*00
	Révision: Revision:	00
	Marque de fabrication ou de commerce: Trade name or mark:	(see information document)
	Type: Type:	FJH
1.	Procès-verbal d'essai: Test report:	N° 88-R122-031/19-00
	- Test report:	Page(s) 1 to 4;
	- List of modifications:	Appendix 0 – Page(s) 5;
	- Test minutes:	Appendix 1 – Page(s) 6;
	- Technical information:	Appendix L – Page(s) 7.
2.	Dossier du constructeur: Report of the manufacturer:	N° FJH-R122-00
	- Manufacturer's information folder:	Page(s) 1 to 15.
3.	Autres documents annexés: Other documents annexed:	not applicable
4.	Date de délivrance de l'homologation initiale: Date of issue of initial type approval:	04.02.2019
5.	Date de la dernière délivrance de pages révisées: Date of last issue of revised pages:	not applicable
6.	Date de la dernière délivrance d'une homologation révisée: Date of last extension:	not applicable

Type : FJH
Manufacturer : Harbin Haoke Science and Technology Co., LTD.

TEST REPORT

according to UN-Regulation

UNIFORM PROVISIONS CONCERNING THE APPROVAL OF VEHICLES OF CATEGORIES M, N AND O WITH REGARD TO THEIR HEATING SYSTEMS

UN-Regulation No.122

including all amendments until

00 series of amendments, supplement 4.

Previously granted

UN approval : --

Structure of the Test Report

Item No.

0. General information
 1. Tested vehicle(s) / object(s)
 2. Test record
 3. Appendices
 4. Statement of conformity
-

The Test Report shall be reproduced and published in full by the client only. It shall however be reproduced and published partially with the written permission of the Testing Laboratory only.

Type : FJH
 Manufacturer : Harbin Haoke Science and Technology Co., LTD.

0. General information

- 0.1. Make (trade name of the manufacturer) :  比来孚; 推特; 兴库; 星库; 驻车
- 0.2. Type : FJH
 Variant(s) : FJH-2/1C, FJH-2.2/1C, FJH-4/1C, FJH-5/1C
- 0.3. Category of vehicle : Not applicable
- 0.4. Name and address of the manufacturer : Harbin Haoke Science and Technology Co., LTD.
 No.19, Xingnan Road, Nangang District, Harbin City, Heilongjiang Province, P.R. China
- 0.5. No. of the information document : FJH-R122-00
 - Date of issue : November 10, 2018
 - Date of last change : Not applicable

1. Tested vehicle(s)/ object(s)

- 1.1. Description
- 1.1.1. ~~Vehicle/~~ object : Air Heater
 Trade name :  比来孚; 推特; 兴库; 星库; 驻车
 Type(s) /variant(s) ~~version(s)~~ : FJH
 Variants: FJH-2/1C, FJH-2.2/1C, FJH-4/1C, FJH-5/1C
 Identification number : FJH-2/1C, FJH-2.2/1C, FJH-4/1C, FJH-5/1C
- 1.1.2. Condition of ~~vehicle(s)/~~Object(s) : New / ~~used~~ / ~~pre-tested~~
- 1.2. Worst case selection : The determination of worst case scenario was done according to internal procedures of the Technical Service (QMA 1.301.005, section 6.2.2.2.).
- 1.3. Remarks : The results of the test refer exclusively to the object(s) mentioned under point 1.1 of this report.
 FJH-2/1C, FJH-2.2/1C, FJH-4/1C are scaled down variants of FJH-5/1C with smaller power.
 The variant FJH-5/1C is taken as the test representative.

Type : FJH
 Manufacturer : Harbin Haoke Science and Technology Co., LTD.

2. Test record

- 2.1. Equipment for measuring and testing : The test facilities / measurement equipment used were in compliance with the test requirements
- 2.1.1. Specifications for the test site : Not applicable
- 2.1.2. Subcontracting : Not applicable
- 2.2. Test results
- 2.2.1. Test results referring to measurement
- 2.2.1.1. General specifications : The heated air entering the passenger compartment is not more polluted than the air at the point of inlet to the vehicle.
- The driver and passengers, during road use, will not be able to come into contact with parts of the vehicle or heated air liable to cause burns.
- The exhaust emissions from combustion heaters are within acceptable limits.
- 2.2.1.2. Waste heating systems-Air (Annex 3) : Not applicable
- 2.2.1.3. Air quality (Annex 4) : The primary circuit of the heat exchanger is subject to a leakage test at a gauge pressure of 0.5 hPa after the tests of Annex 5, 6 and paragraph 1.3. of Annex 7, the leakage rate from the heat exchanger is less than or equal to 30 dm³/h.
- 2.2.1.4. Temperature (Annex 5) : The combustion heater is operated for one hour at maximum output in conditions of still air (wind speed ≤ 2 m/s). The ambient temperature is not less than 15°C.
- The surface temperature of any part of the heating system likely to come into contact with any driver of the vehicle during normal road use does not exceed a temperature of 70°C for uncoated metal or 80°C for other materials.
- The temperature does not exceed 110°C in the case of overheating for the exposed parts of heating system outside the passenger compartment.
- The temperature of heated air entering the passenger compartment does not exceed 150°C to be measured at the center of the outlet.
- 2.2.1.5. Exhaust emissions (Annex 6) : The requirements of the standards are met (Test data see Appendix 1)
- 2.2.1.6. Requirements for combustion heater (Annex 7) : The requirements of the standards are met (Test data see Appendix 1)

Type : FJH
 Manufacturer : Harbin Haoke Science and Technology Co., LTD.

- 2.2.2. Test results of not measurable attributes : Not applicable
- 2.2.3. Alternative test methods : Not applicable
- Remark concerning extension : ~~The vehicle type has been tested according to the modification(s) mentioned in appendix 0.~~
~~The new parts meet the requirements of the regulation.~~
~~An actual practical test of the vehicle was not necessary.~~
~~The results of the previous test(s) are still valid.~~
- 2.3. Additional information : The results of the test refer exclusively to the object(s) mentioned under point 1.1. of this report.
- Test site : National Agricultural Machinery Quality Supervision and Inspection Center (Gu'an Laboratory)
 Yingbin Road, Gu'an, Langfang, Hebei Province, China
- Test date : December 10, 2018
- 2.4. Remarks : Not applicable

3. Appendices

- Appendix 0 : List of modifications
- Appendix 1 : Test minutes
- Appendix L : Technical information about the heating system according to Annex 1, Part 2, Appendix 2 for the communication of the ECE-type approval
- Information folder : FJH-R122-00 (15 pages)

4. Statement of conformity

The in section 0.5. mentioned information document and the type described in that comply with the requirements mentioned on page 1.

With regard to the required level of performance to be achieved, the tested samples were representative for the type to be approved (see section 1.2).

The mentioned test results refer to the ~~vehicle(s)/~~object(s) described under section 1.1 of this report.

Engineering Centre Shanghai, January 8, 2019
 MT/LCL

Teng Ma

Teng Ma
 Expert Technical Service



Type : FJH
Manufacturer : Harbin Haoke Science and Technology Co., LTD.

List of modifications

Appendix 0

Correction of : ---

Modification of : ---

Addition of : ---

Deletion of : ---

Type : FJH
 Manufacturer : Harbin Haoke Science and Technology Co., LTD.

Test minutes

Appendix 1

1. Exhaust emission test results

	Limit	Voltage			Unit
		10.5 V	12.0 V	13.9 V	
CO emission in still wind	≤0.1	0.002	0.002	0.002	Vol.%
CO emission at 100 km/h	≤0.2	0.002	0.002	0.002	Vol.%
HC emission	≤100	0	0	0	ppm
NOx emission	≤200	68.5	67.7	68.2	ppm
Smoke value according to Bacharach	≤4	0.01	0.01	0.01	---
Exhaust temperature	---	239.8	251.0	251.2	°C
Ambient air temperature	10 ~ 30	14.8	14.8	14.8	°C
Ambient pressure	---	100.1	100.1	100.1	kPa

2. Additional requirement for combustion heaters

2.1. Installation instruction and operating instruction are supplied with every heater

2.2. Fuel supply switching off

Limit	Time duration	Unit	Remark
≤240	179	s	No flame burning at start-up
≤240	215	s	Flame goes out during operation

2.3. Test pressure of combustion chamber and heat exchanger : Not applicable

2.4. Type label of combustion heater meets the requirements of this Annex.

2.5. Delayed shut-off of combustion air blowers

Limit	Time duration	Unit	Remark
---	273	s	Overheating
---	246	s	Interruption of fuel supply

2.6. Requirements for electrical supply : All tests have been carried out in the voltage range from 10.5V to 13.9V because under voltage protection is provided.

2.7. Warning light : There is a clearly visible tell-tale to show whether the combustion heater is switched on or off.

Type : FJH
 Manufacturer : Harbin Haoke Science and Technology Co., LTD.

Technical information about the heating system according to Annex 1, Part 2,
 Appendix 2 for the communication of the ECE-type approval

APPENDIX L

SECTION I

GENERAL

- 1.1. Make (trade name of manufacturer) : 比来孚; 推特; 兴库; 星库; 驻车
- 1.2. Type : FJH
 Variants: FJH-2/1C, FJH-2.2/1C, FJH-4/1C, FJH-5/1C
- 1.3. Means of identification of type, if marked on the device ^(b) : FJH-2/1C, FJH-2.2/1C, FJH-4/1C, FJH-5/1C
- 1.3.1. Location of that marking : Printed on the data plate of the combustion heater
- 1.4. Name and address of manufacturer : Harbin Haoke Science and Technology Co., Ltd.
 No.19, Xingnan Road, Nangang District, Harbin City,
 Heilongjiang Province, P.R. China
- 1.5. Location of the approval mark : Printed on the data plate of the combustion heater
- 1.6. Address(es) of assembly plant(s) : Harbin Haoke Science and Technology Co., Ltd.
 No.19, Xingnan Road, Nangang District, Harbin City,
 Heilongjiang Province, P.R. China

SECTION II

1. Additional information (where applicable) : Not applicable
2. Technical service responsible for carrying out the tests : TÜV Rheinland Luxemburg GmbH
 2a, Kalchesbruck
 L-1852 Luxemburg
3. Date of test report : January 8, 2019
4. Number of test report : 88-R122-031/19-00
5. Remark(if any) : Not applicable

^(b) If the means of identification of type contains characters not relevant to describe the vehicle, component or separate technical unit types covered in this information document, such characters shall be represented in the documentation by the symbol "?" (e.g. ABC??123??)



INFORMATION DOCUMENT

CONCERNING THE APPROVAL OF COMPONENT WITH REGARD TO A COMBUSTION HEATER

(UN Regulation No. 122. Amendment 00, supplement 4)

HEATER TYPE: FJH

APPLICATION HISTORY

Update No.	Date of issue	Reason for update	Page(s) modified
00	November 10, 2018	Original version	---

**INDEX**

Section:	Page:	Subject:
1	3	GENERAL
2	3	COMBUSTION HEATER (IF ANY)

LIST OF ATTACHMENTS

Annex:	Page:	Subject:
A	4-5	Drawing of combustion heater
B	6	Description of the combustion heater
C	7-10	Manufacturer's label
D	11	Circuit Diagram
E	12-13	PCB layout
F	14-15	Bill of materials

Mr. Zheng Shutong
Saturday, 10 November 2018

**1. GENERAL**

- 1.1. Make (trade name of manufacturer) : 比来孚; 推特; 兴库; 星库; 驻车
- 1.2. Type and general commercial description(s)
- Type : FJH
- Variants : FJH-2/1C, FJH-2.2/1C, FJH-4/1C, FJH-5/1C
- 1.3. Name and address of the manufacturer : Harbin Haoke Science and Technology Co., Ltd.
No.19, Xingnan Road, Nangang District, Harbin City,
Heilongjiang Province, P.R. China
- 1.4. In the case of components, location and method of affixing of the type-approval mark: : Printed on the data plate of the combustion heater.
- 1.5. Address(es) of assembly plant(s) : Harbin Haoke Science and Technology Co., Ltd.
No.19, Xingnan Road, Nangang District, Harbin City,
Heilongjiang Province, P.R. China

2. COMBUSTION HEATER (IF ANY)

- 2.1. Make (trade name of manufacturer) : 比来孚; 推特; 兴库; 星库; 驻车
- 2.2. Type and general commercial description(s)
- Type : FJH
- Variants : FJH-2/1C, FJH-2.2/1C, FJH-4/1C, FJH-5/1C
- 2.3. Means of identification of type, if marked on the heating system : Printed on a label which is affixed on the housing of the heater
- 2.4. Location of that marking : On the housing of the heater.
- 2.5. Name and address of the manufacturer : Harbin Haoke Science and Technology Co., Ltd.
No.19, Xingnan Road, Nangang District, Harbin City,
Heilongjiang Province, P.R. China
- 2.6. Address(es) of assembly plant(s) : Harbin Haoke Science and Technology Co., Ltd.
No.19, Xingnan Road, Nangang District, Harbin City,
Heilongjiang Province, P.R. China
- 2.7. Test pressure (in the case of a combustion heater fuelled by liquefied petroleum gas or similar, the pressure applied at the gas inlet connector of the heater) : Not applicable
- 2.8. Detailed description, layout drawings and mounting description of the combustion heater and all its components : See Annex A – F

Drawing of combustion heater

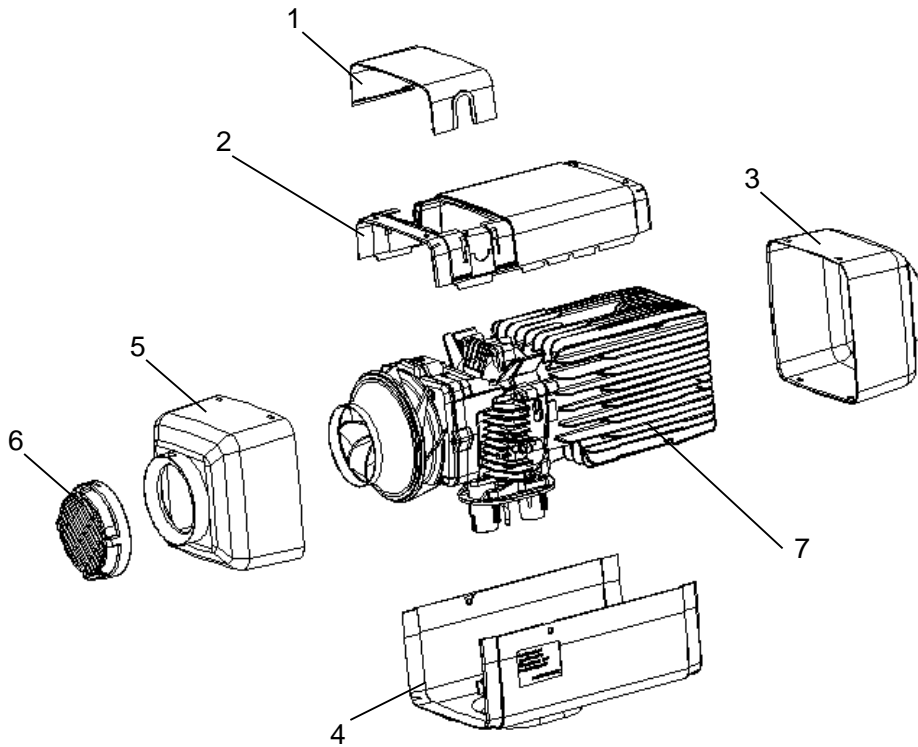

NO.	Name	Quantity
1	Junction box cover	1
2	Top hood-shape cover	1
3	Hot air outlet	1
4	Bottom hood-shape cover	1
5	Air inlet of heater	1
6	Air inlet/exhaust hood	1
7	Burner	1

Drawing of main burner

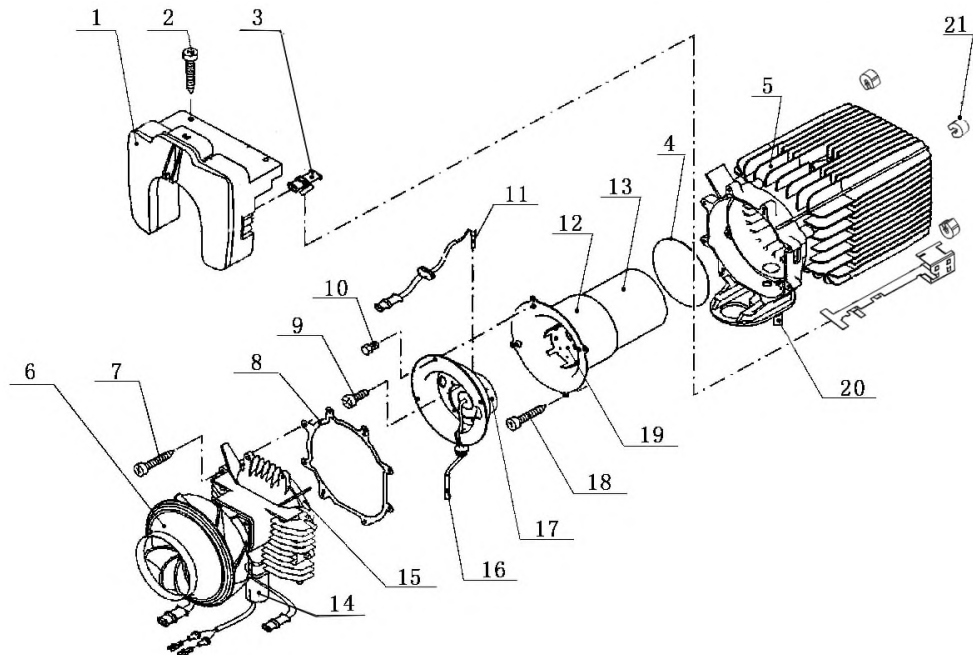

NO.	Name	Quantity
1	Controller	1
2	Screw	2
3	Overheat sensor	1
4	O-ring	1
5	Heat exchanger	1
6	Fan motor assembly	1
7	Screw	8
8	Seal of heat exchanger	1
9	Screw	4
10	Screw	4
11	Glow plug/Flame sensor	1
12	Pipe base	1
13	Guide pipe	1
14	Inlet of combustion supporting air	1
15	Blade wheel of heating fan	1
16	Fuel inlet pipe	1
17	Combustor core	1
18	Screw	4
19	Combustion pipe	1
20	Exhaust pipe vent	1
21	Insulating mat	4



Description of the combustion heater

1. Introduction

The main equipment of Model 5KW air parking heater (hereinafter referred to as the heater) is a small fuel furnace controlled by a single-chip micro-processor. Its furnace body (the heat exchanger) is located in the hood-shape case, which serves as independent air passage. Cold air is sucked into the air passage by the heat supplying fan and blown out when it becomes hot, so as to form another heating system that is to the original heating system of the vehicles. In such a way, heat can be supplied by the heater to driver's cab and passengers' compartment no matter the engine is working or not working.

The heater is fully automatically controlled. It features in compact structure, easy installation, energy-saving, environmental protection, safety and reliability, easy maintenance, etc.

2. Main technical specifications

Heater Model	FJH-2/1C	FJH-2.2/1C	FJH-4/1C	FJH-5/1C
Heat Power (W)	2000	2200	4000	5000
Fuel	Diesel			
Rated Voltage	DC12V			
Working Voltage	10.5V-16V			
Fuel Consumption	0.12~0.24	0.1~0.28	0.11~0.51	0.19~0.60
Rated Power Consumption (W)	29	24	34	90
Working (Environment) Temperature	-40°C ~ +35°C			
Working height above sea level	≤1500m			
Weight of Main Heater (kg)	2.6	2.7	4.5	5.9
Dimensions (mm)	323×120×121	305×105×122	371×140×150	425×148×162
Mobile phone control (Optional)	No limitation			

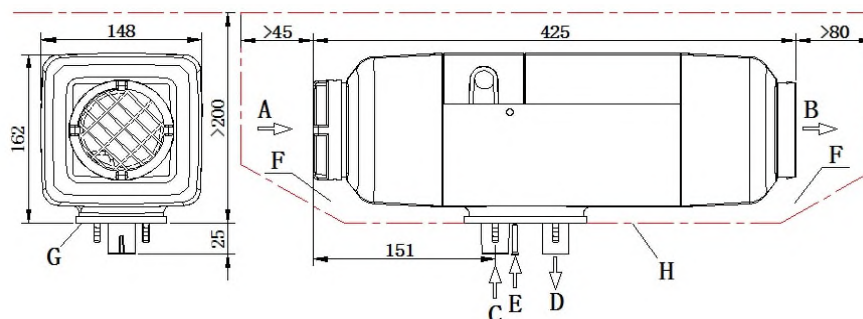

Trial operation is necessary for the heater before it is put into normal use. At trial operation, you have to check leakage from all connections and all safety issues. If discharge of dense smoke is observed or irregular combustion noise or fuel smell is sensed, the heater must be turned off. Please take out the fuse, making the heater unable to operate. The heater can only be put into use after it is tested by qualified professionals.

Before each heating season, check shall be performed by qualified professionals for maintenance works, details as follows:

- Check air inlet and air outlet to find any pollution or foreign matters.
- Clean the external of the heater.
- Check if there is any corrosion or loose connection for electric contacts.
- Check to find any clogging and damage to the air inlet pipe and exhaust pipe.
- Check to find any leakage on the fuel pipe.

If the heater will not work for a long time, you'd better run it once every four weeks and let it run for 10 minutes at least to prevent malfunction of mechanical parts.

The air inlet port and air outlet vent of the heater must be kept clean and unblocked to provide smooth route for air flow,

so as to prevent overheating.

If fuel is replaced with low-temperature fuel, run the heater for at least 15 minutes to fill new fuel into the fuel pipe and fuel pump.

The heat exchanger of the heater cannot work for longer than 10 years. When it has worked for ten years, it must be replaced with a qualified one. The replace work must be performed by the heater manufacturer or its authorized agent. At this time, the overheating sensor shall be replaced too. The exhaust pipe of the heater for discharge of waste gas after combustion, if arranged in an area with passengers, shall be replaced with qualified one when it has worked for 10 years.

3. Installation

Only special-purpose parts can be used for installation of the heater. Fig. 9 is the diagram for installation. The positions and ways of fixing of various parts may vary from one automobile model to another, but the general principles must be followed in conformity with the requirements of this chapter. Otherwise the heater may not work normally or safety problems may occur.

Requirements for Installation and Places of Application of the Heater

It is not allowed to use the heater in locations with inflammable or explosive substances such as flammable gas or flammable dust.

It is not allowed to use the heater in closed space (such as garage or maintenance workshop without air ventilation) to avoid danger of poisoning due to exhaust from burning.

Attention: Under either of the above circumstances, it is not allowed to use the heater even at the timer stand-by state or wireless remote control state.

It is not allowed to install and use the heater in bedrooms.

If the heater is installed in special-purpose vehicles (such as vehicles for dangerous goods), special rules must be followed in installing the heater.

Never place fuel tank, compression tank, fire extinguisher, clothes, paper, etc. near the heater or opposite to the hot air vent.

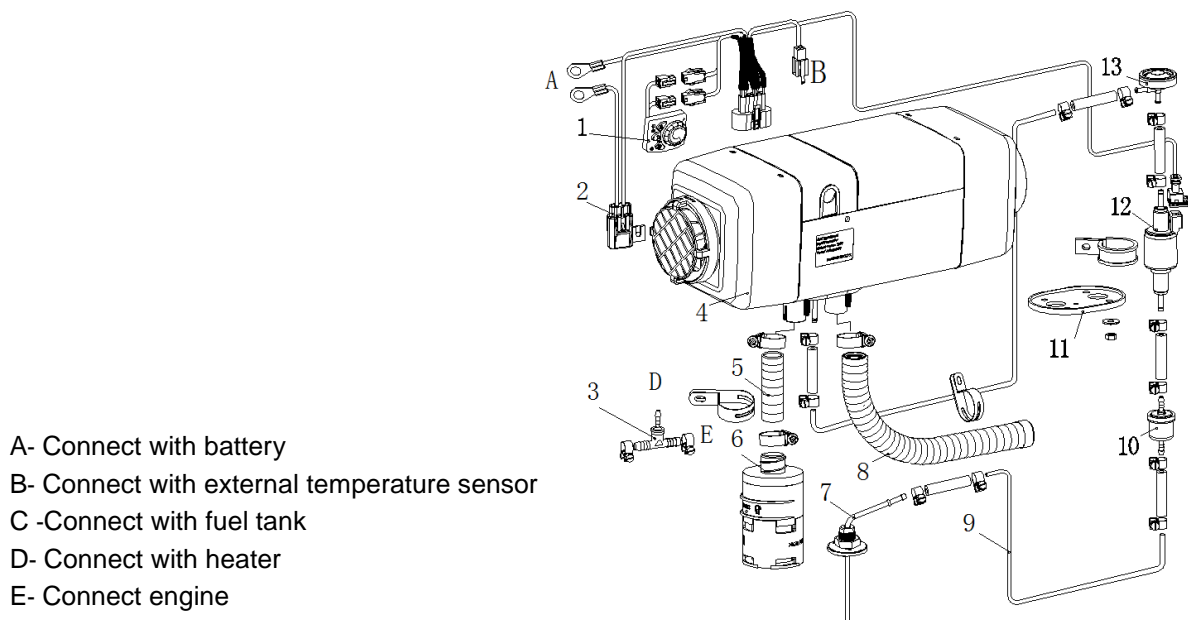

Fig. 9

- 1-Control switch 2- Fuse holder 3- Reducing T 4-Heater 5- Air inlet pipe
 6-Air filter(optional choice) 7-Fuel suction pipe 8- Exhaust pipe
 9- Fuel pipe 10-Filter 11-Gasket 12- Fuel pump 13- Damper

Installation of the Main Heater

The main heater can be installed inside the vehicle or outside the vehicle. But when it is installed outside the vehicle a shield which can prevent the damage (splash of stones) of external force (supplied by retailers). The heater can't be soaked in the water or in the rain for a long time (heater should be shut off). The heater should be operated after it is completely dried if the heater is corroded by rain and water.

If the heater is installed outside the vehicle, measures must be taken to avoid splash of water onto the heater.

For convenience of heating air flow and installation, maintenance of the main heater, enough space must be provided for installation. Please refer to the scope of double dot line for the space for installation, as shown in Fig. 10.

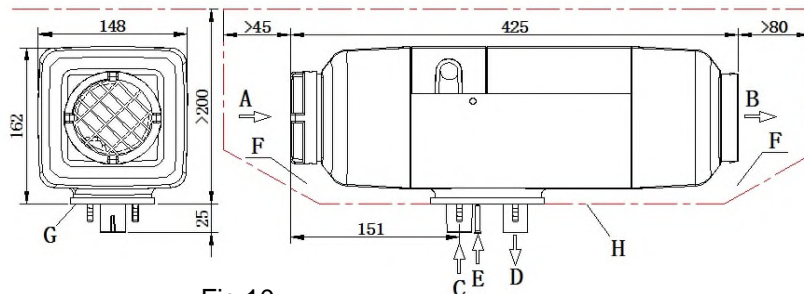

Fig.10

- A-Inlet of heating air B-Outlet of heated air
 C-Inlet of combustion supporting air D-Discharge of exhaust
 E-Fuel inlet F-Non-interference area G-Installation surface H-Gasket

Please make sure that there is not any foreign matter in the gap between the bottom surface of the main heater and the installation surface of the vehicle (Fig. 10-F).

Good sealing is necessary between the main heater and the installation surface on the vehicle. A special gasket (as shown in Fig. 10) supplied by the manufacturer must be inserted in between during installation. The installation surface must be smooth and steady enough. Its parts at the installation bases of the main heater shall have unevenness of less than 1mm. After drilling installation holes, evenness must be improved according to this requirement. At installation, please rotate the four M6 nuts, which provided by the manufacturer should be tighten. The torque for tightening shall be 6Nm+1Nm. Please refer to Fig. 11 for positions of installation holes.

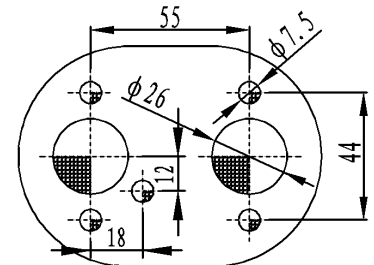

Fig. 11

Attention: For re-installation of the main heater, a new gasket must be used to replace the old one.

If the sickness of the installation panel < 1.5mm a mounting plate may need. Between mounting plate and the car body must also be sealed (use glass glue Fig.12).

Direction for installation of the main heater is shown in Fig.13. Attention must be paid to that the inclination angle (A for gasoline heater, B for diesel heater) shall not exceed the limit showed in Fig.13, or normal operation will be affected.

After installation of the main heater, please check and make sure that there is not any contact or friction between the blade wheel of fan and other nearby parts to avoid unsmooth operation.

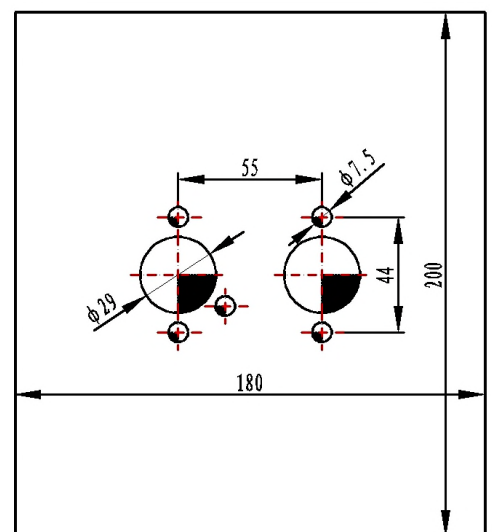

Fig.12



Installation of Air Heating System

The independent outer circulation or inner circulation mode of heater can be recommended. If the air heating system of the heater have to be connected with the air duct of the vehicle, in order to ensure the air duct unobstructed

the connection way should be analyzed by the professionals.

When an external heating air pipe is attached to the heater, the pipe diameter shall not be smaller than 90mm. Its material shall be capable to resist temperature of 130°C.

The maximum pressure drop between the air inlet side and air outlet side of the air heating system shall not be greater than 0.15kPa.

The hot air from the heating system shall not erupt onto such parts that are unable to resist heat. In case of passenger vehicles, measures shall be taken to avoid blocking of the hot air vent by passengers. A self-provided protective net can be installed if necessary.

For heater working in external circulation mode, the position of air inlet port shall be proper to guaranteed that under normal operation no splash of water can enter. No water can be sucked into the heater and no exhaust from the engine can be sucked in.

For heater working in internal circulation, measures shall be taken to avoid re-entering of the supplied hot air into the air inlet port (as shown in Fig. 14). The inlet air shall be drawn from the cold area of the compartment, such as under the seats or berths. If no air inlet pipe is attached in this mode, an air inlet hood with grids (Fig. 4-6) must be installed at the air inlet port of the main heater.

The optional air duct fittings

Users can choose the air duct fittings in table 3 according to the situation. Please refer to Fig.15. Specification of φ60 can only use for branch pipe.

Table 3

No.	Name	Specification
A	Grill	φ90
		φ60
B	Diameter changes joint	φ89/85
		φ90/60
		φ60/56
C	Elbow	φ90/90
		φ60/90
D	Clamp	φ80~100
		φ50~70
E	Ducting	φ90/95
		φ60/64
F	Connector	φ90-φ90
		φ60-φ60
G	Reducing T	φ90
		φ60

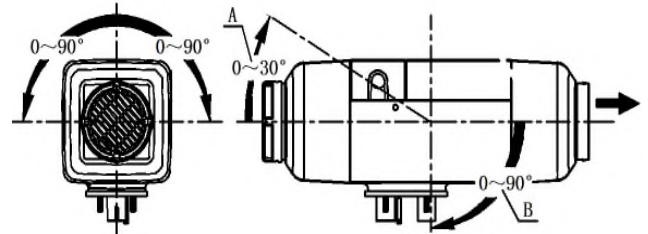
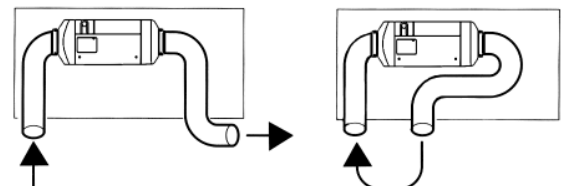

Fig. 13



a) Correct Fig. 14 b) Wrong

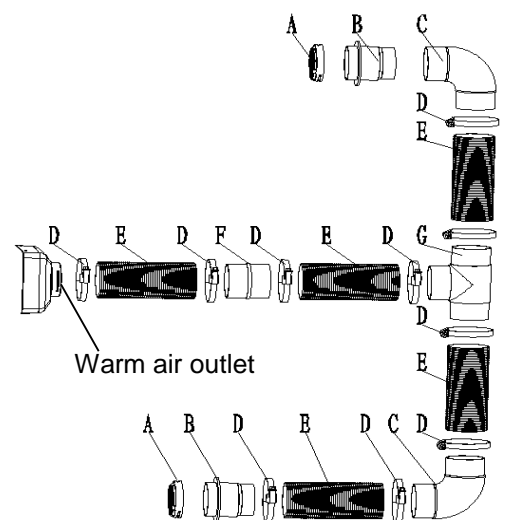
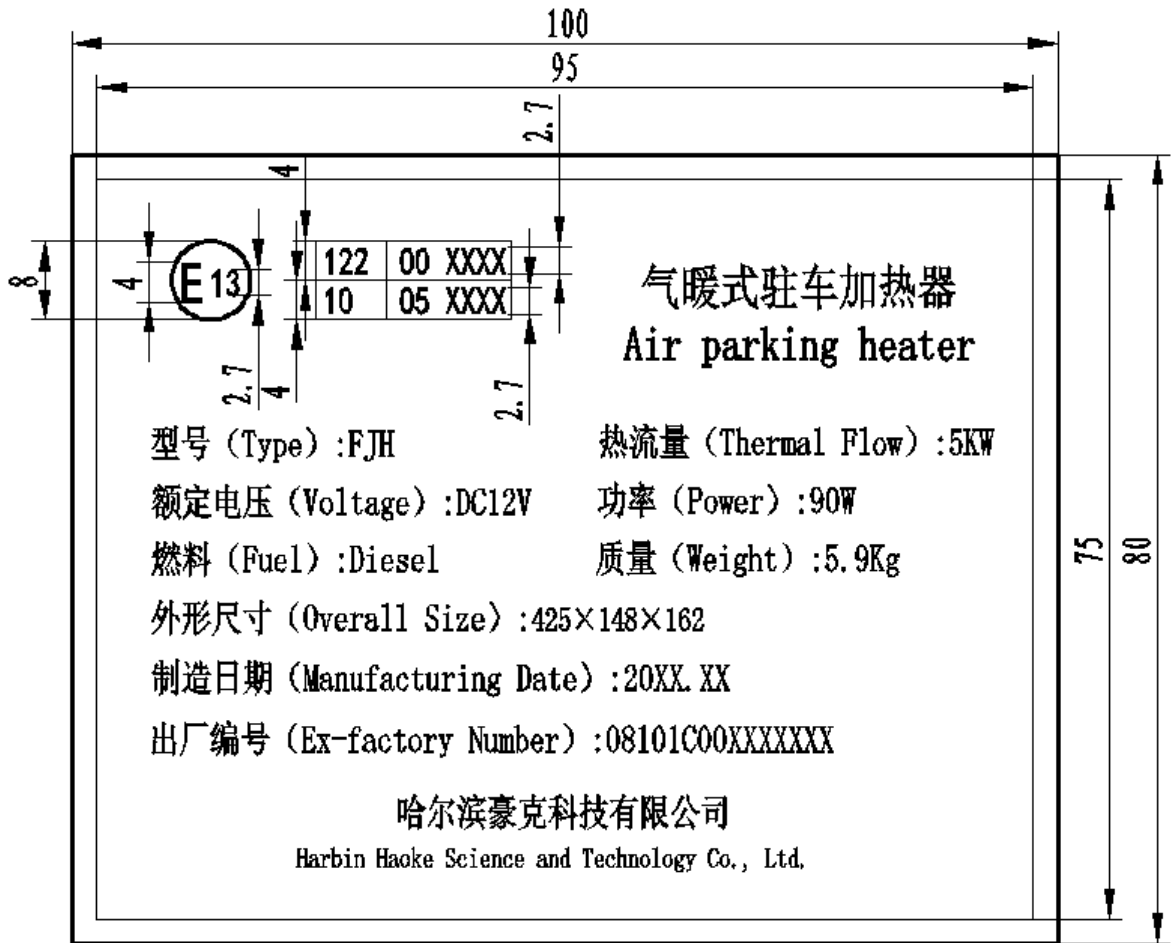

Fig. 15



Manufacturer's label





Circuit Diagram

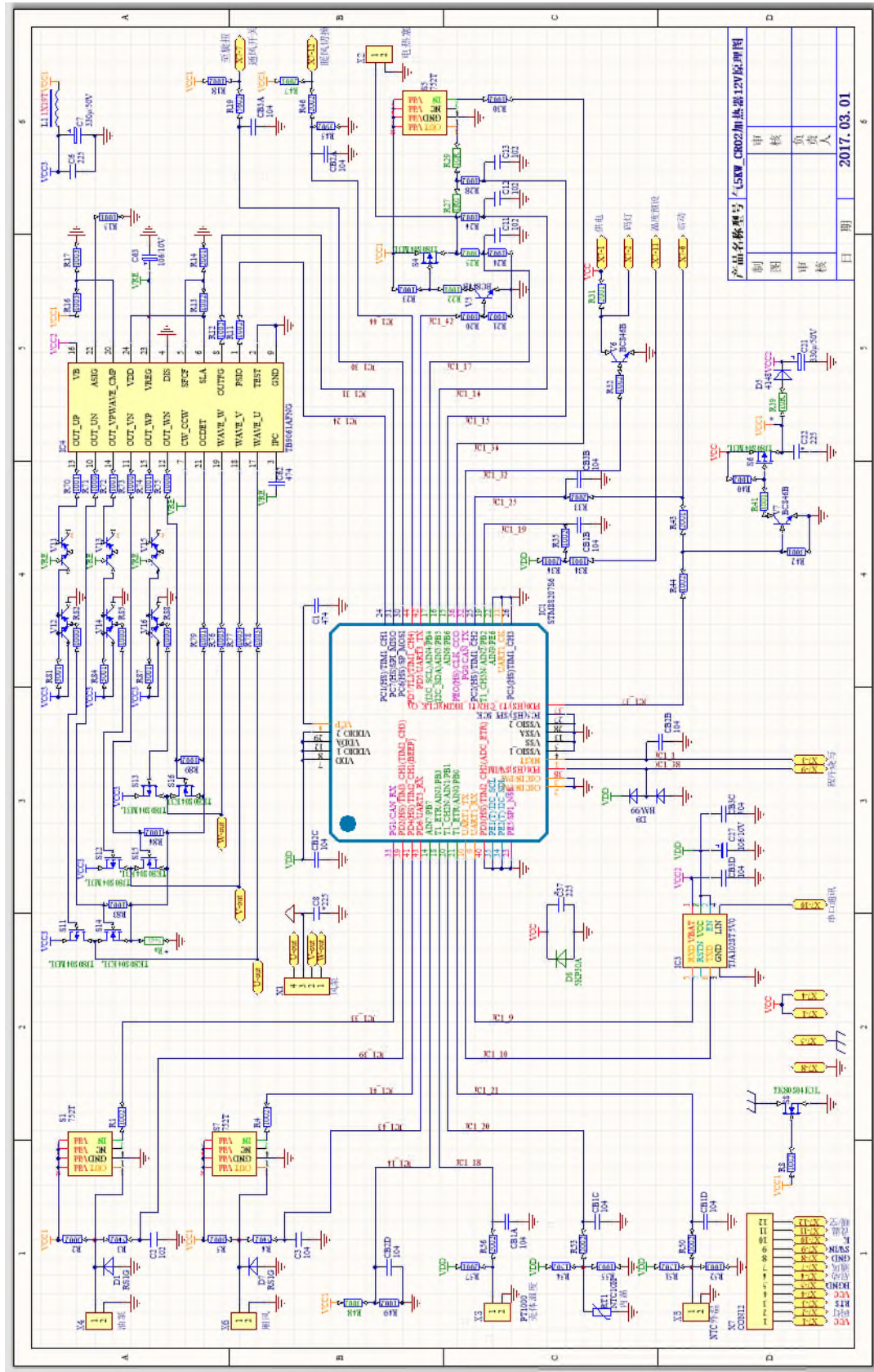



PCB layout

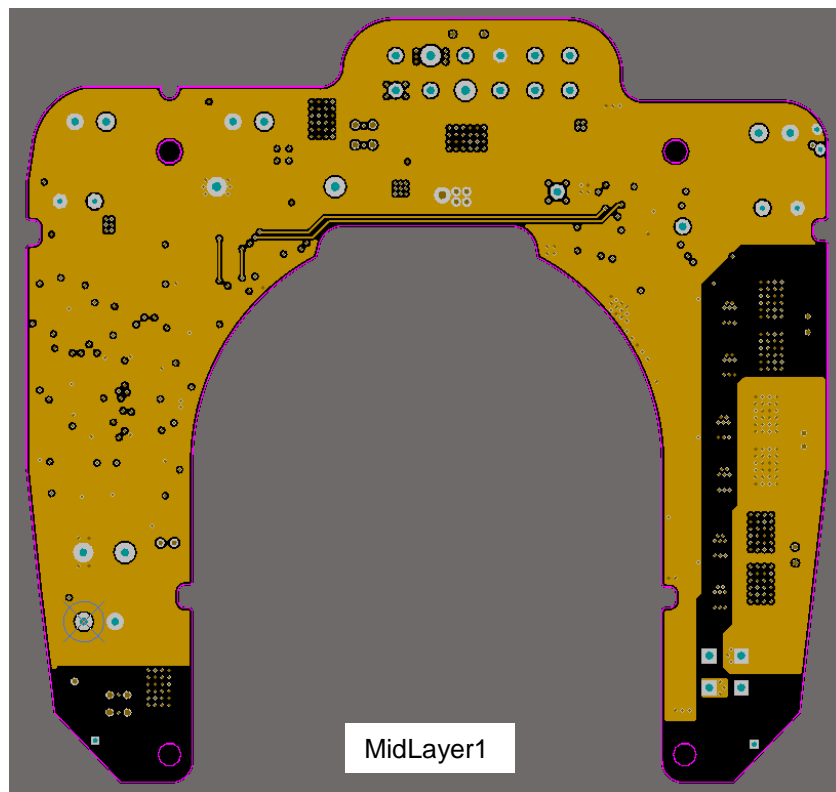
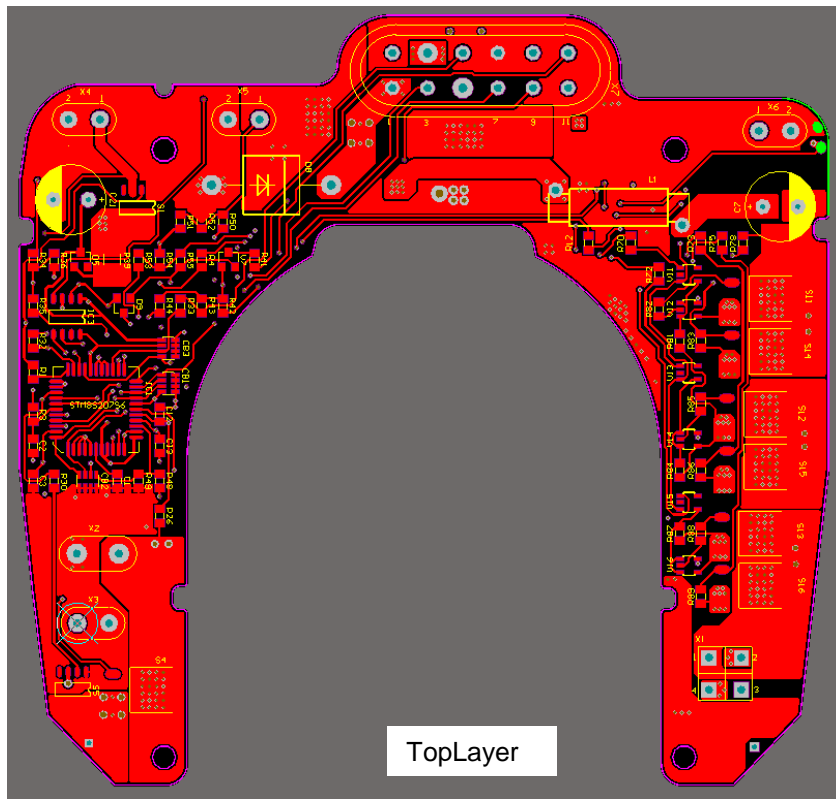

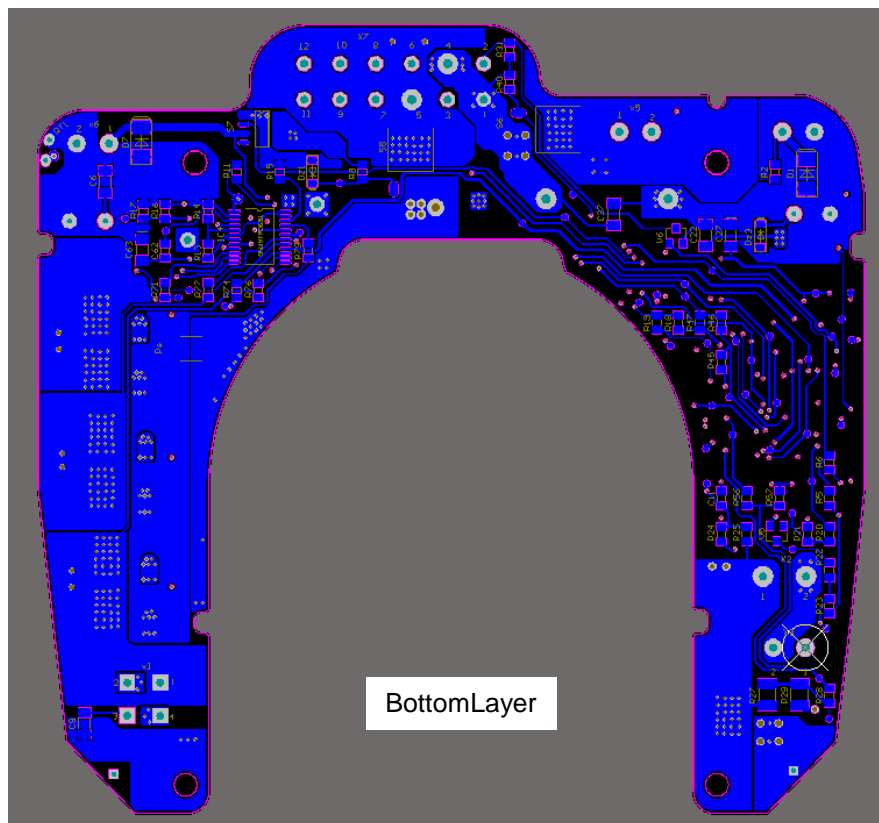
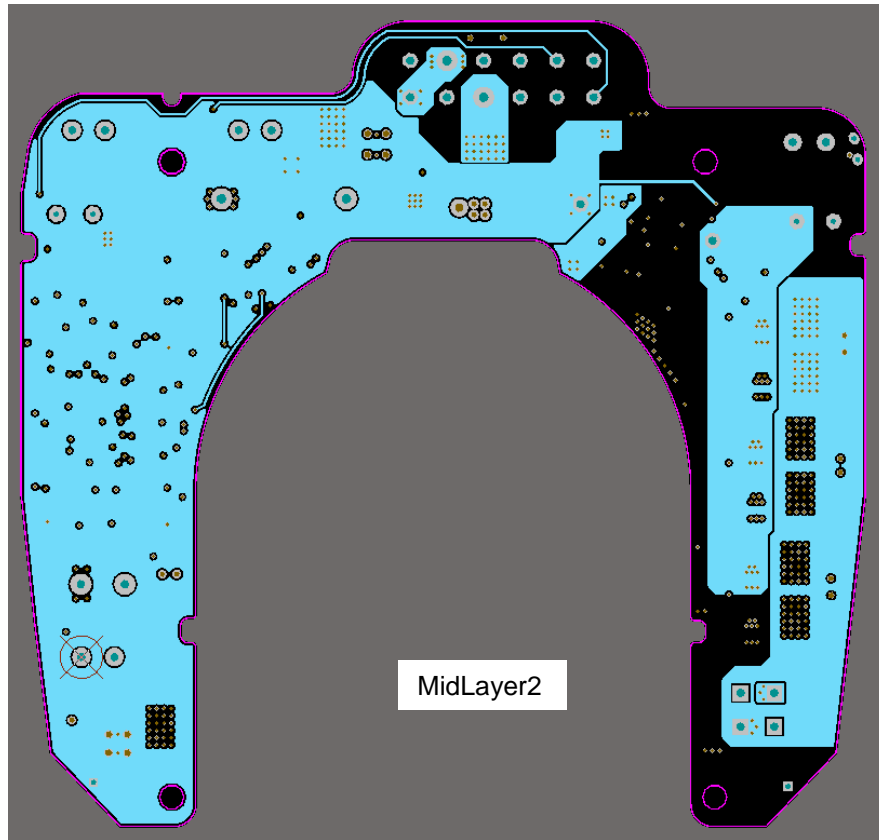

**Bill of materials**

Item No.	Comment	Specification/Description	QTY (PC)	Position	Manufacturer
1	MCU	LQFP-44,STM8S207S6	1	IC1	STMicroelectronics
2	LIN transceiver	SO-8,TJA1028T/5V0	1	IC3	NXP 恩智浦半导体
3	Pre-driver	SSOP24,TB9061AFNG	1	IC4	TOSHIBA 东芝
4	P-MOSFET	TO-252,TJ80S04M3L	5	S4、S6、S11、S12、S13	TOSHIBA 东芝
5	N-MOSFET	TO-252,TK80S04K3L	4	S8、S14、S15、S16	TOSHIBA 东芝
6	PROFET	SO-8,BSP752T	2	S1、S5	Infineon 英飞凌
7	Transistor	SOT-23,BC846B,NPN	3	V5、V6、V7	PANJIT 强茂
8	Dual transistors	SMT5,FMY1A, NPN+PNP	6	V11、V12、V13、V14、V15、V16	ROHM 罗姆半导体
9	Chip Diode	SMA,RS1G	1	D1	指日高
10	Chip Diode	SOT-23,4148	1	D5	PANJIT 强茂
11	Chip Diode	SOT-23,BAV99	1	D9	NXP 恩智浦半导体
12	Plug-in Diode	P600,5KP30A	1	D8	NANJING SUNRISE
13	Chip Resistor	2010,RL10FTNTR005	1	Rs	HEL 海利斯特
14	Chip Resistor	1210,1 Ω \pm 1%	1	R27	Yageo 国巨
15	Chip Resistor	1210,10 Ω \pm 1%	2	R29、R39	Yageo 国巨
16	Chip Resistor	0805,100 Ω \pm 1%	6	R71、R73、R75、R82、R85、R88	Yageo 国巨
17	Chip Resistor	0805,1k \pm 1%	8	R15、R22、R34、R41、R70、R72、R74、R79	Yageo 国巨
18	Chip Resistor	0805,10k \pm 1%	21	R1、R8、R11、R12、R13、R18、R20、R21、R23、R24、R26、R28、R30、R32、R35、R40、R44、R49、R83、R86、R89	Yageo 国巨
19	Chip Resistor	0805,100k \pm 1%	7	R16、R17、R52、R55、R76、R77、R78	Yageo 国巨
20	Chip Resistor	0805,15k \pm 1%	2	R51、R54	Yageo 国巨
21	Chip Resistor	0805,2k \pm 1%	6	R14、R31、R36、R43、R47、R57	Yageo 国巨
22	Chip Resistor	0805,20k \pm 1%	5	R33、R46、R50、R53、R56	Yageo 国巨
23	Chip Resistor	0805,3k \pm 1%	4	R42、R81、R84、R87	Yageo 国巨



Item No.	Comment	Specification/Description	QTY (PC)	Position	manufacturer
24	Chip Resistor	0805,30k \pm 1%	2	R2、R5、R25、R48	Yageo 国巨
25	Chip Resistor	0805,39k \pm 1%	1	R45	Yageo 国巨
26	Chip Resistor	0805,56k \pm 1%	5	R3、R6、R19	Yageo 国巨
27	NTC Resistor	Plug-in, MF52E-103F3950FA	1	RT1	AMPRON 安培龙
28	Chip Capacitor	0805, CL21B102KB	4	C2、C11、C12、C13	Yageo 国巨
29	Chip Capacitor	0805, CL21B474KB	2	C1、C62	Yageo 国巨
30	Chip Capacitor	1206, CL31B104KACNBN	3	CB1、CB2、CB3	Yageo 国巨
31	Chip Capacitor	1206, CL31B225KB	4	C6、C8、C22、C37	SAMSUNG 三星
32	Chip Capacitor	1206, CA45-106-10V	2	C27、C63	Sunlord 顺络
33	Electrolytic Capacitor	ϕ 10 \times 16, CD286-330 μ /50V	2	C7、C21	SAMYOUNG 三莹
34	Plug-in Magnet Inductor	0.8 \times 19, ϕ 4 \times 20	1	L	Haoke 豪克
35	PCB	110 \times 115 \times 1.5,4 layers	1		Shenzhen Hongda Youlian