



LED LIGHT MOUNTING KIT INSTALLATION INSTRUCTIONS

PARTS INCLUDED:

- 1 - 6" Edge LED Light Kit
- 1 - Mounting Bracket

TOOLS NEEDED:

- 7/16 wrench or socket
- 17mm wrench or socket

INSTALLATION

Congratulations on purchasing the latest in ATV lighting technology! To mount your new light kit you will have to remove the handle bar mounting system from your quad, and mount the bracket between the handle bar clamp and the steering stem. Use the two holes shown below. You shouldn't have to remove your handle bars from the mount, or any of the controls on the bars.

Once you have the mount installed as shown below, you can install the light into the mounting bracket using the supplied hardware with the light. Make sure the white compression spacers are located between the bracket and the light housing as shown, or damage to the light can result.

Wiring- It uses a simple 2 wire hook up. **Make sure the red wire is connected to the hot (+) lead.** If they are crossed, the light will be damaged permanently, and will not be covered under warranty!

WARNING!

DO NOT HOOK UP WIRES BACKWARDS
LIGHT HOUSING WILL BE PERMANENTLY DAMAGED
AND WILL NOT WORK!!

WARNING!

LIGHT MUST BE USED WITH DC CHARGING SYSTEMS EQUIPPED
WITH A BATTERY. IF USED ON NON BATTERY ELECTRICAL SYSTEMS
DAMAGE TO LIGHT MAY OCCUR FROM TOO MUCH VOLTAGE.

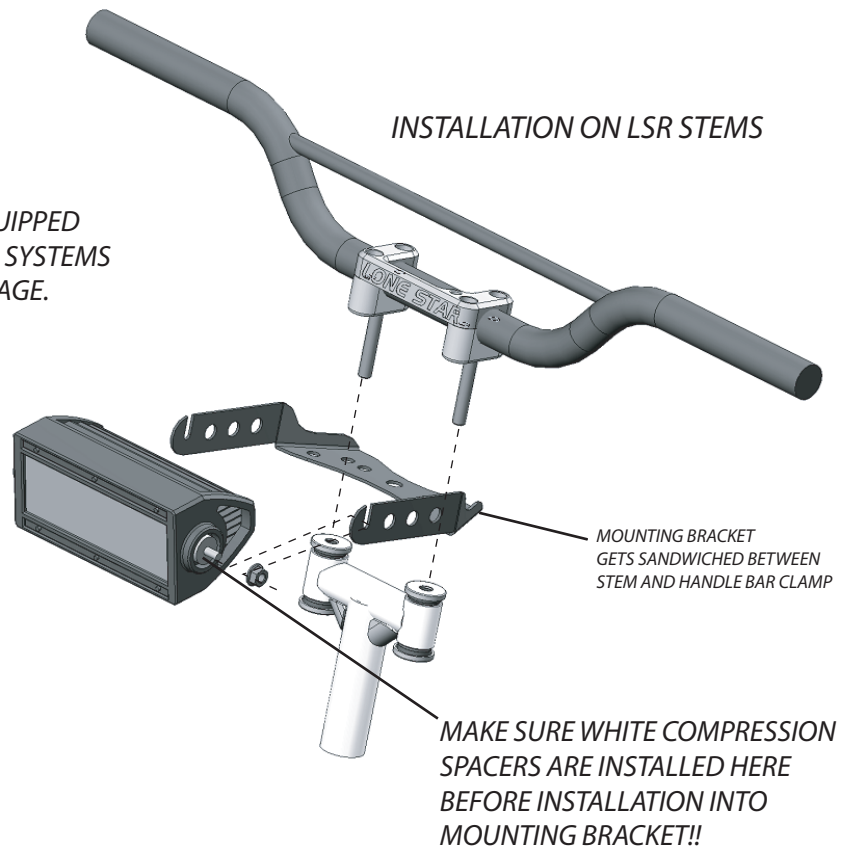
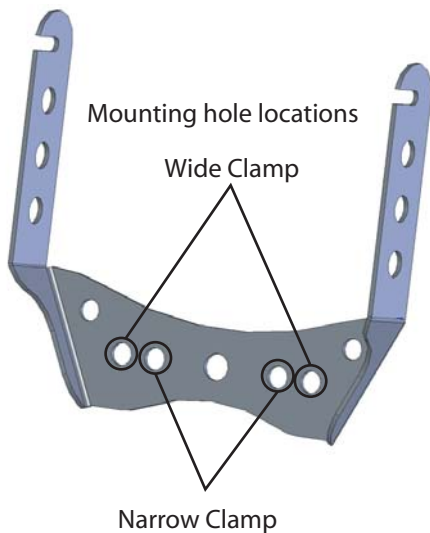

MOUNTING ISSUES

LSR STEMS: IF BOLTS BECOME TOO SHORT FOR NUTS TO LOCK ON, YOU CAN REMOVE THE ALUMINUM WASHERS THAT MAKE CONTACT WITH THE LIGHT MOUNTING BRACKET SO THEY WILL REACH A LITTLE MORE.

IT MIGHT BE NECESSARY TO RELOCATE A KEY SWITCH OR DASH ASSEMBLY IN ORDER TO USE THE LIGHT SYSTEM.

MAKE SURE TO ROUTE THE CABLES AND WIRING SO THEY DON'T BIND WHEN THE HANDLE BARS ARE TURNED LOCK TO LOCK.

CLEANING/ MAINTAINING:

Use soap and water to clean, taking care not to use high pressure pointed at the light housing itself.
Make sure mounting hardware is tight.