

XEBEX

F I T N E S S

AIR BIKE AB-1

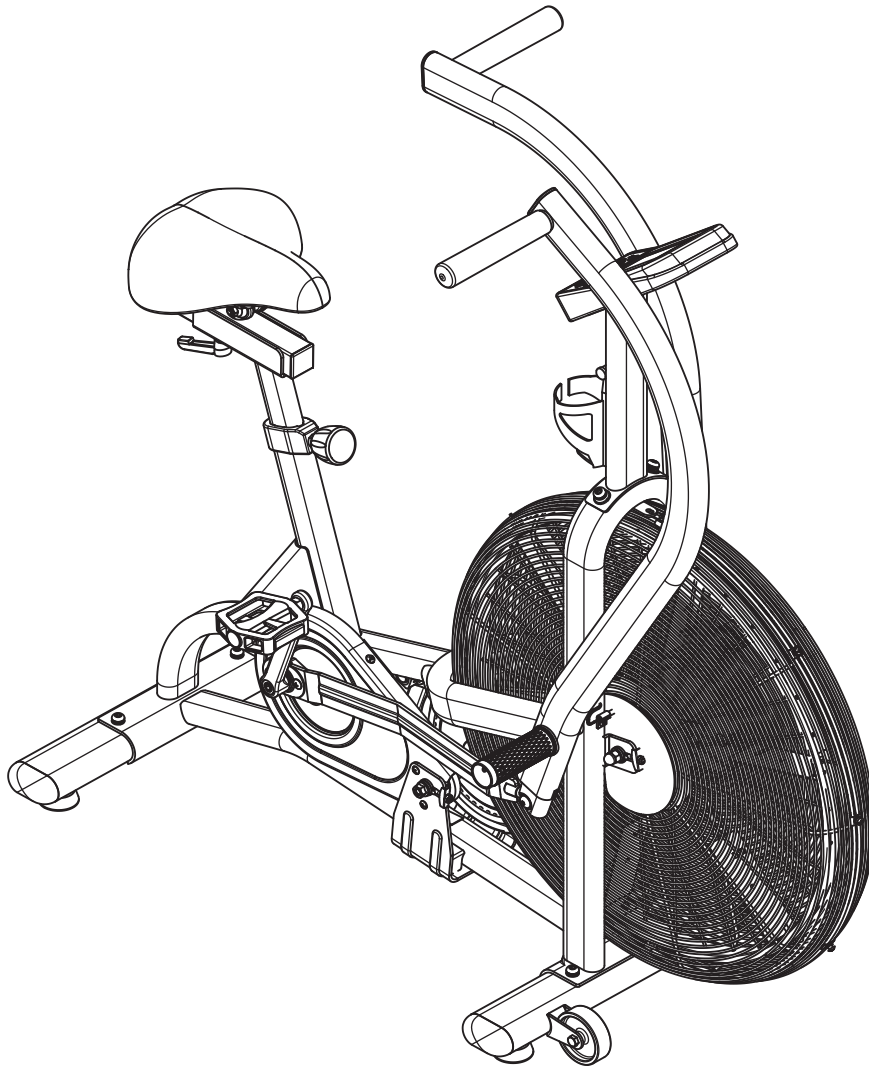

ASSEMBLY INSTRUCTIONS / OWNERS MANUAL

IMPORTANT : READ ALL ASSEMBLY INSTRUCTIONS AND SAFETY PRECAUTIONS BEFORE USING THIS PRODUCT. REFERENCE ALL SAFETY GUIDELINES AND WARNING LABELS. RETAIN PRODUCT LITERATURE FOR FUTURE REFERENCE.

SAFETY : PROPERLY WARM UP AND STRETCH BEFORE EXERCISING. IF YOU FEEL PAIN OR DIZZINESS AT ANY TIME WHILE EXERCISING, STOP IMMEDIATELY AND CONSULT YOUR PHYSICIAN.

ASSEMBLY PREPARATION

- To ensure ease of product assembly, please take time to verify the size and quantities of all required assembly hardware. Use the itemized parts listing and hardware chart for reference.
- The product assembly process has been documented in easy to follow stages. Please read all assembly instructions carefully. Take time to review the manual and familiarize yourself with the entire assembly process before proceeding.

Assembly Tip: It is always helpful to pre-stage the items needed for each assembly step.

- Perform product assembly in a 4ft. x 6ft. flat area. Note: After assembly is completed, allow a minimal of 2-3ft. of space on each side of bike for user access and dismounting.
- Do not dispose of any packaging materials until assembly of the product is completed.
- Assembly tools are included, but you may also use standard household tools to complete assembly of this product.
- If you experience problems with operation of the equipment after assembly, please reference the troubleshooting guide in this manual.
- For added component life, follow the preventative maintenance tips listed in this manual.
- Make sure to completely fill-out the product registration form & return it to us within 30-days of purchase.

IMPORTANT PRECAUTIONS

WARNING: To reduce the risk of injury, please read the following precautions before assembling or using your new product.

1. It is the responsibility of the owner to ensure that all users of this equipment are adequately informed of stated precautions.
2. Read all instructions and enclosed literature carefully. Understand the assembly and operation before using the equipment.
3. Use equipment on a flat level surface. Use adjustment levelers on the bottom of equipment to help stabilize unit.
4. It's recommended to place an exercise mat beneath the equipment for added protection of floors or carpets.
5. Keep children & pets away from equipment at all times.
6. Inspect product on a frequent basis. Tighten loose assemblies or hardware as needed. Replace worn or damaged parts.
7. This equipment is intended for indoor use only. Use in non-recommended environment can lead to serious injury and will void all related warranties & liabilities.
8. Recommended user weight should not exceed **300 lbs**.
9. Keep equipment clean and properly maintained.
10. Observe and adhere to all warning labels posted on equipment.
11. Properly warm-up and stretch before starting any strength training or cardio exercise routine.
12. If you feel pain or dizziness at any time while exercising, stop immediately and consult your physician.

Safety Warning: Before starting an exercise program, consult your physician. This is especially important for individuals over the age of 35 or persons with pre-existing health problems. It's important to read all instructions carefully. We assume no responsibility for personal injury or consequential damages sustained by or through the use of this equipment. Additional terms & conditions are listed in the back of this manual or enclosed owners manual.

Colors and specifications are subject to change without notice.

ASSEMBLY PARTS LISTING

ITEM#	DESCRIPTION	Q'TY
1	BASE FRAME ASSEMBLY	1
2	FRONT STABILIZER ASSEMBLY	1
3	REAR FRONT STABILIZER ASSEMBLY	1
4	SENSOR CABLE	1
5	CONSOLE	1
6	CONSOLE MAST	1
7	ADJUSTABLE SEAT SLIDER	1
8	SEAT POST	1
9	SEAT	1
10	SEAT SLIDER ADJUSTABLE KNOB	1
15	CONNECTING ARM (PREINSTALLED)	2
16	LEFT PIVOT ARM ASSEMBLY	1
17	RIGHT PIVOT ARM ASSEMBLY	1
18	FOOT REST	2
20	LEFT PEDAL	1
21	RIGHT PEDAL	1
22	BUTTON HEAD ALLEN BOLT M8*20 LENGTH	6
23	SPRING WASHER 12*8.5*1.5T	12
24	WASHER 18*8.5*1.5T	14
25	BOLTS M5*10 LENGTH	2
26	PAN HEAD SCREW	2
30	PIVOT BOLT M8*35 LENGTH	2
31	SPACER WASHER 12*8.2*3.5T	2
32	NYLON NUT M8	2
35	CAGE , WATER BOTTLE	1

Assembly Parts

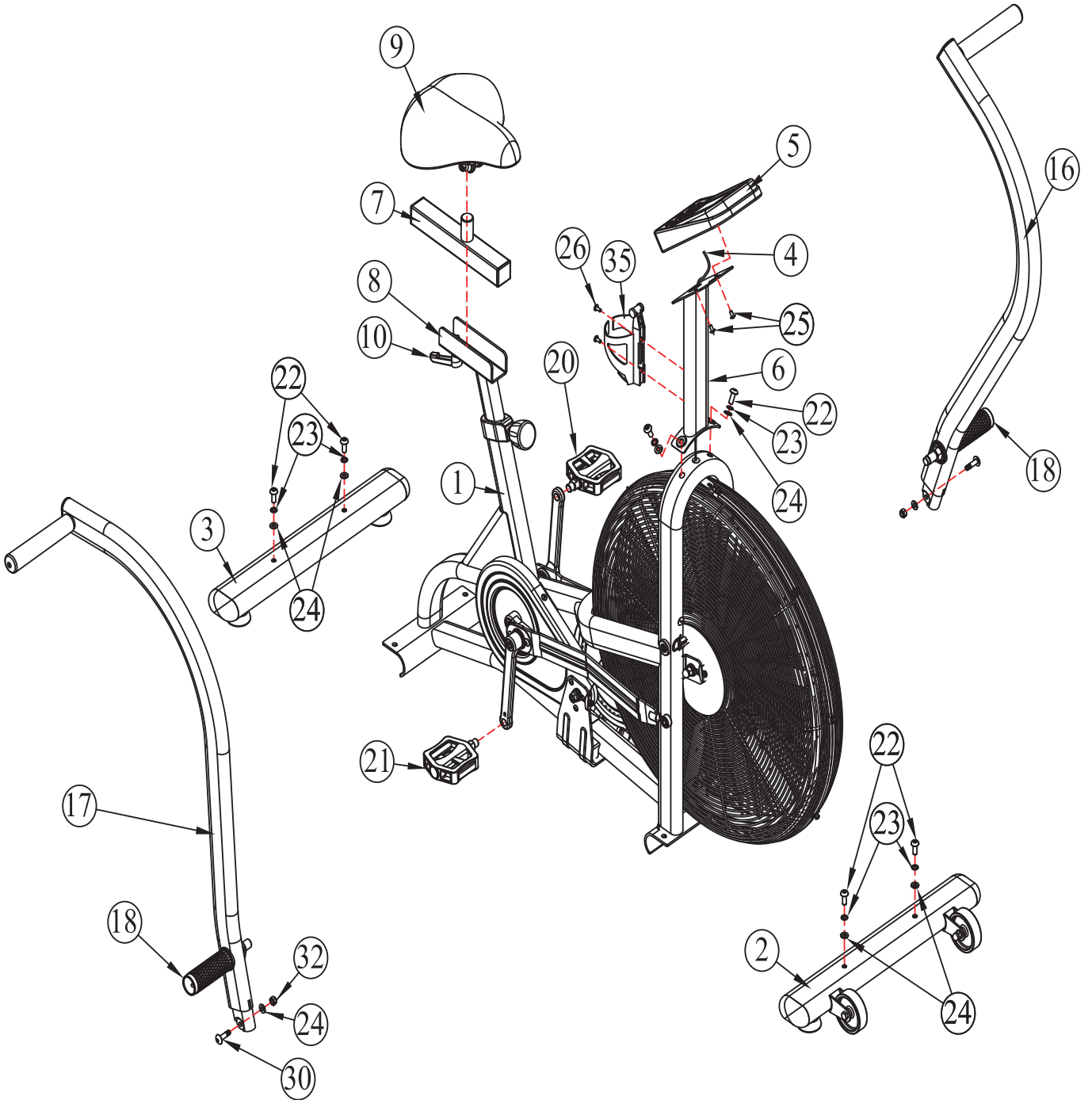

NOTE: THE EXPLODED PARTS VIEW IS SHOWN FOR REFERENCE ONLY. SOME ITEMS MAY BE PREASSEMBLED. PLEASE REFER TO THE INDIVIDUAL ASSEMBLY STAGE INSTRUCTIONS FOR DETAILED PARTS ORIENTATION.

ASSEMBLY STAGE #1

Attach Stabilizers to the Main Base

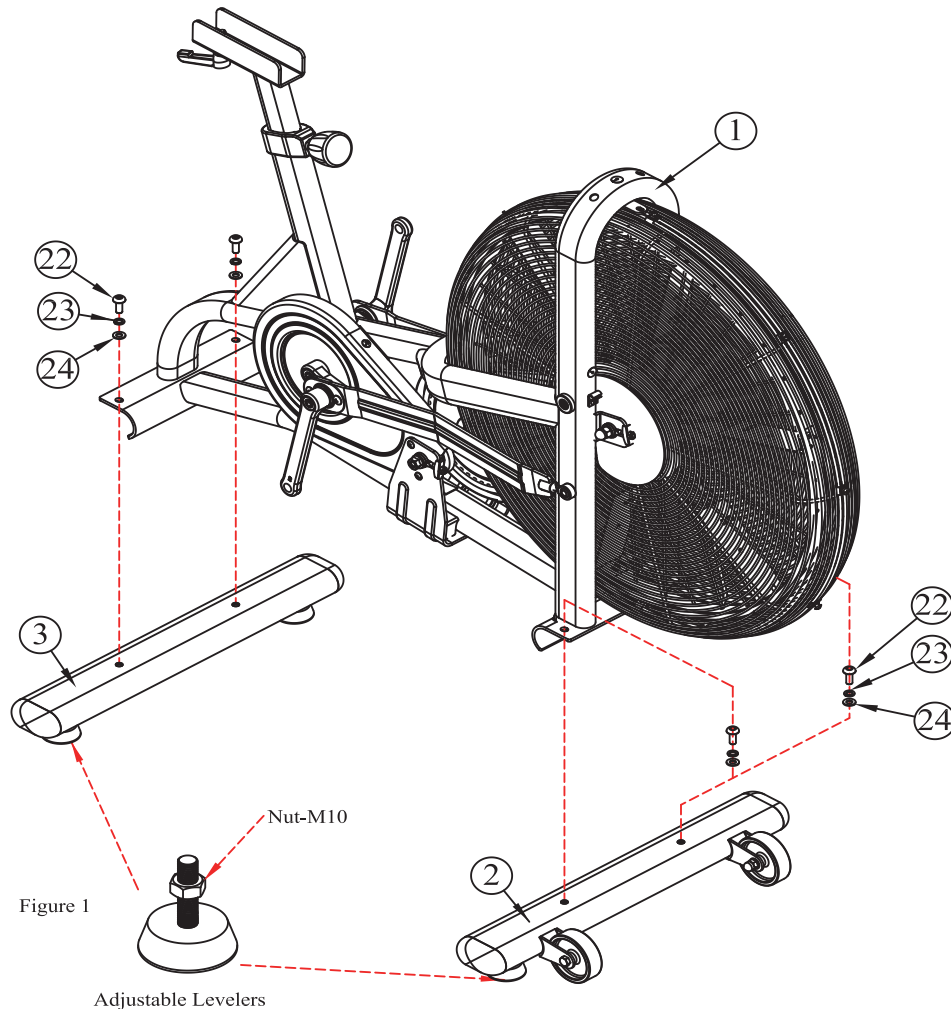

Assembly Hardware Required:

#22	Button Head Allen Bolt	Qty. 4	#24	Washer	Qty. 4
#23	Spring Washer	Qty. 4			

Assembly Description:

- Assemble the **Front Stabilizer Assembly (#2)** to the **Main Base Assembly (#1)** using 2-**Button Head Allen Bolt (#22)**, 2-**Spring Washers (#23)**, and 2-**Washers (#24)**. **Note:** Make sure that the transport wheels on the Front Stabilizer are facing away from the Main Base Assembly as shown.
 - Assemble the **Rear Stabilizer Assembly (#3)** to the **Main Base Assembly (#1)** using 2-**Button Head Allen Bolt (#22)**, 2-**Spring Washers (#23)**, and 2-**Washers (#24)**.
 - Use the **Adjustable Levelers** on the bottom of the **Stabilizer Assemblies** to adjust the bike and keep it from rocking on an uneven surface (Figure 1).
- **Assembly Step #1 completed.**

ASSEMBLY STAGE #2

Attach Console Mast & Mount Computer on the Main Base

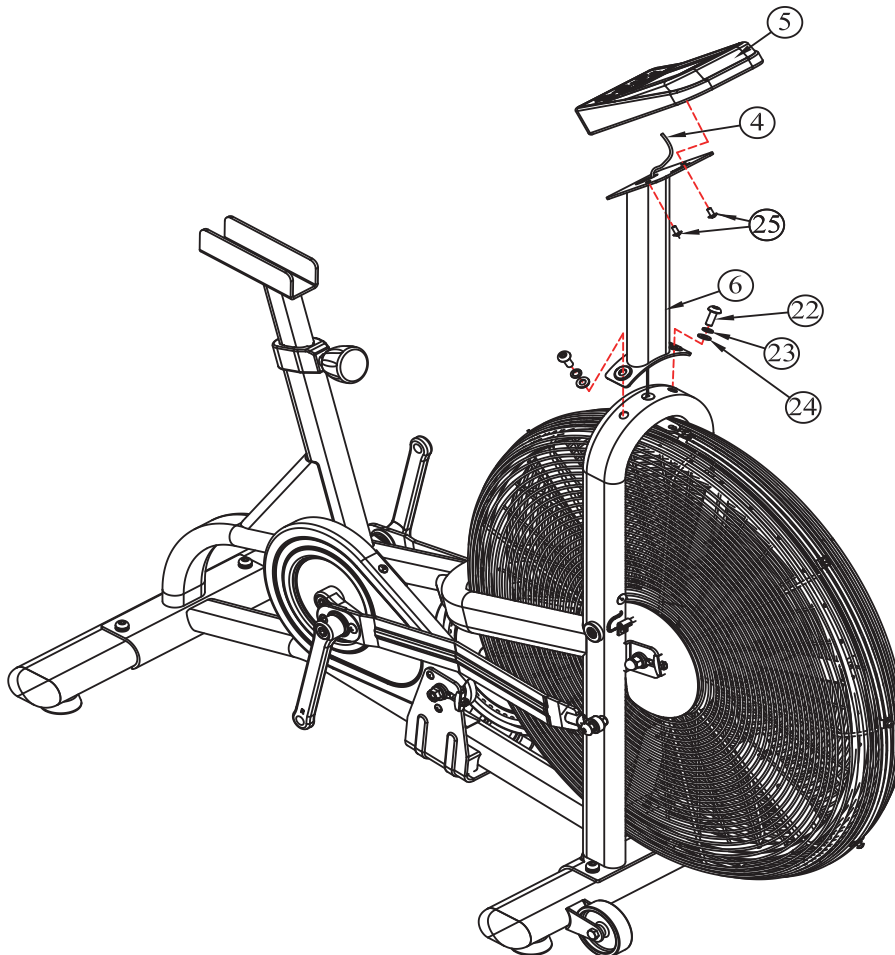

Assembly Hardware Required:

#22	Button Head Allen Bolt	Qty. 2	#23	Spring Washer	Qty. 2
#24	Washer	Qty. 2			

Assembly Description:

- A) Carefully route the **Sensor Cable (#4)** through the **Computer Mast (#6)** and slide the mast down onto the corresponding mounting area of the **Base Frame Assembly**. Secure the mast to the base frame using **2-Button Head Allen Bolts (#22)**, **2-Spring Washers (#23)**, and **2-Washers (#24)**.
 - B) Install (2) **C Batteries** into the back of the **Computer (#5)**, Connect the **Sensor Cable (#4)** to the receptacle end of the cable coming from the back of the computer. Tuck the excess cable length into the mast and slide the computer onto the mast mounting plate. Secure the computer in place using **2-Bolts (#25)**.
- **Assembly Stage #2 completed.**

ASSEMBLY STAGE #3

Attach Seat Slider and Seat to Main Base Assembly

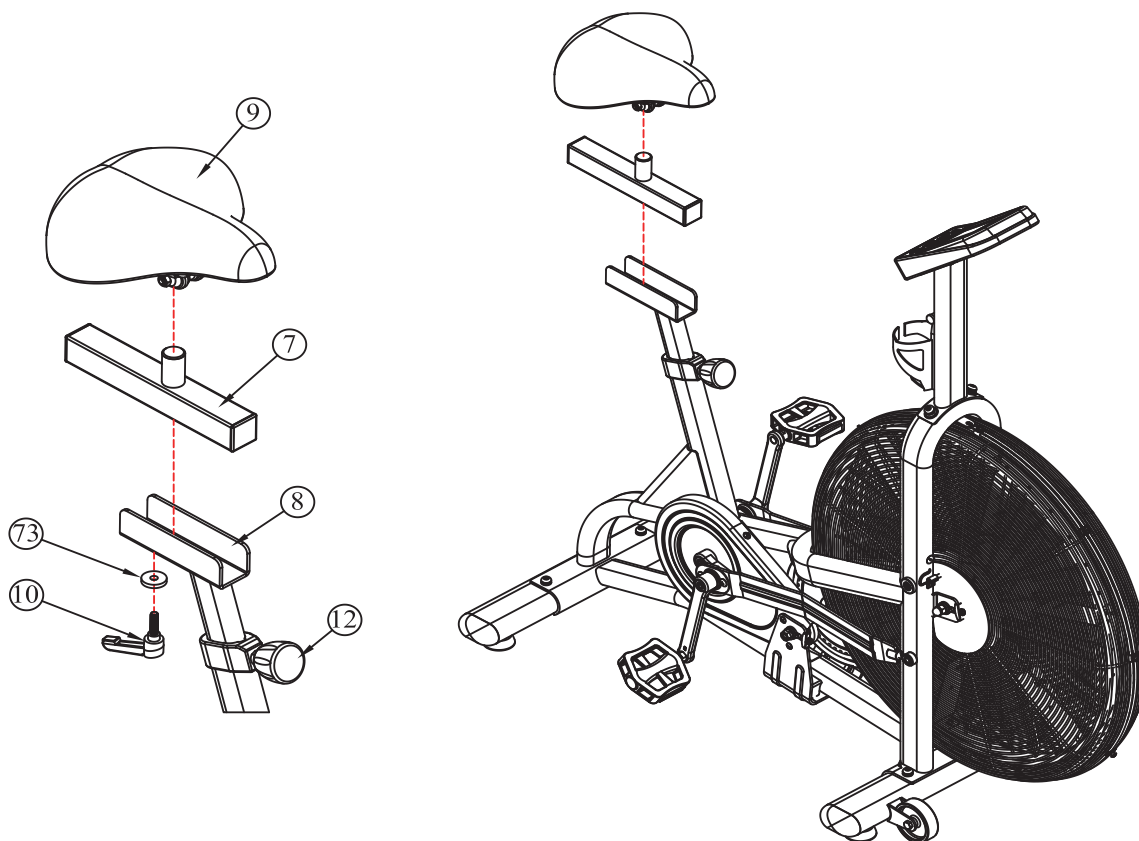

Assembly Description:

- A) Insert the **Adjustable Seat Slider** (#7) into the u-channel of the **Seat Support Post** (#8). Secure the seat slider assembly in place using the **1-Seat Adjustment Knob** (#10).
- B) Assemble **Seat** (#9) onto the knurled post of the seat slider. Set the seat at the desired position and secure it in place by tightening the u-clamp on the underside. Tighten the clamp until the seat no longer twists or tilts.

Seat Adjustments: Adjust the seat height by unscrewing and pulling out on the **Seat Post Adjustment Knob** (#12). Select a desired seat post height and retighten the knob until seat post is secure. **Proper Height Adjustment:** Adjust seat height so the user is comfortable during use (pedaling motion). As a reference point, the users leg should be slightly bent at the bottom of the pedal stroke. The horizontal seat position can be adjusted using the **Seat Slider** (#7). Note: If the seat post wobbles during use, make sure the u-clamp and all adjustment knobs are securely tightened.

- **Assembly Stage #3 completed.**

ASSEMBLY STAGE #4

Attach Pivot Arms to the Main Base

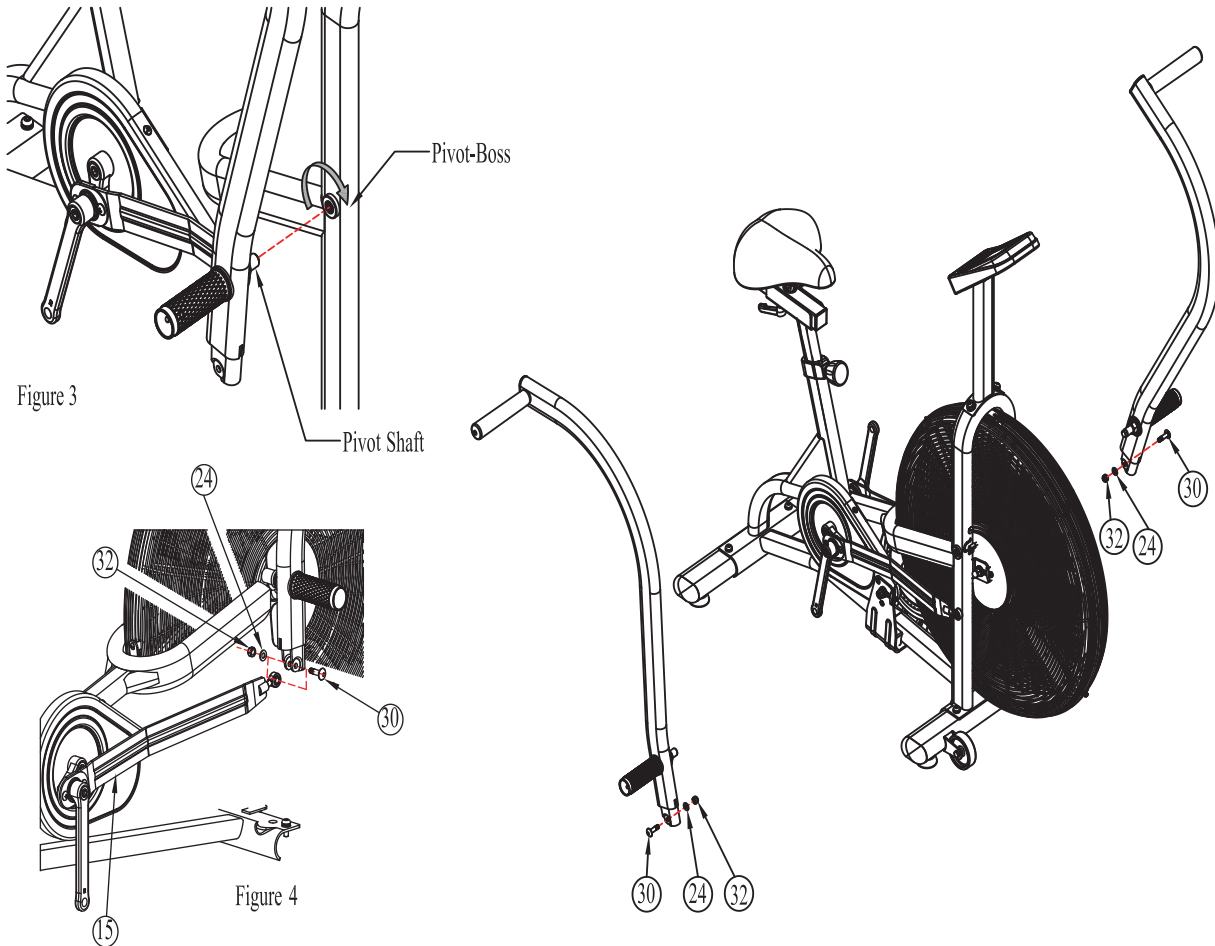

Assembly Hardware Required:

#24	Flat Washer	Qty. 2	#30	Pivot Bolt M8	Qty. 2
#32	Nylon Nut M8	Qty. 2			

Assembly Description:

- A) Install the **Pivot Arms** (#16 & #17) by threading the (preinstalled) pivot shaft into the corresponding pivot-boss of the **Base Frame Assembly** (#1). Using a standard crescent wrench (not included), thread each shaft into the pivot-boss using a clockwise rotation. Fully tighten each shaft until it is flush against the pivot-boss of the Base Frame Assembly. (Reference Figure #3)
- B) Once the Pivot Arms are mounted to the Base Frame Assembly, attach the ends of the **Connecting Arms** (#15) using 1-**Pivot Bolt** (#30), 1-**Flat Washer** (#24), and 1-**Nylon Nut** (#32) per side. (Figure #4).

- Assembly Stage #4 completed.

ASSEMBLY STAGE #5

Attach Pedals & Foot Rest to the Main Base Assembly

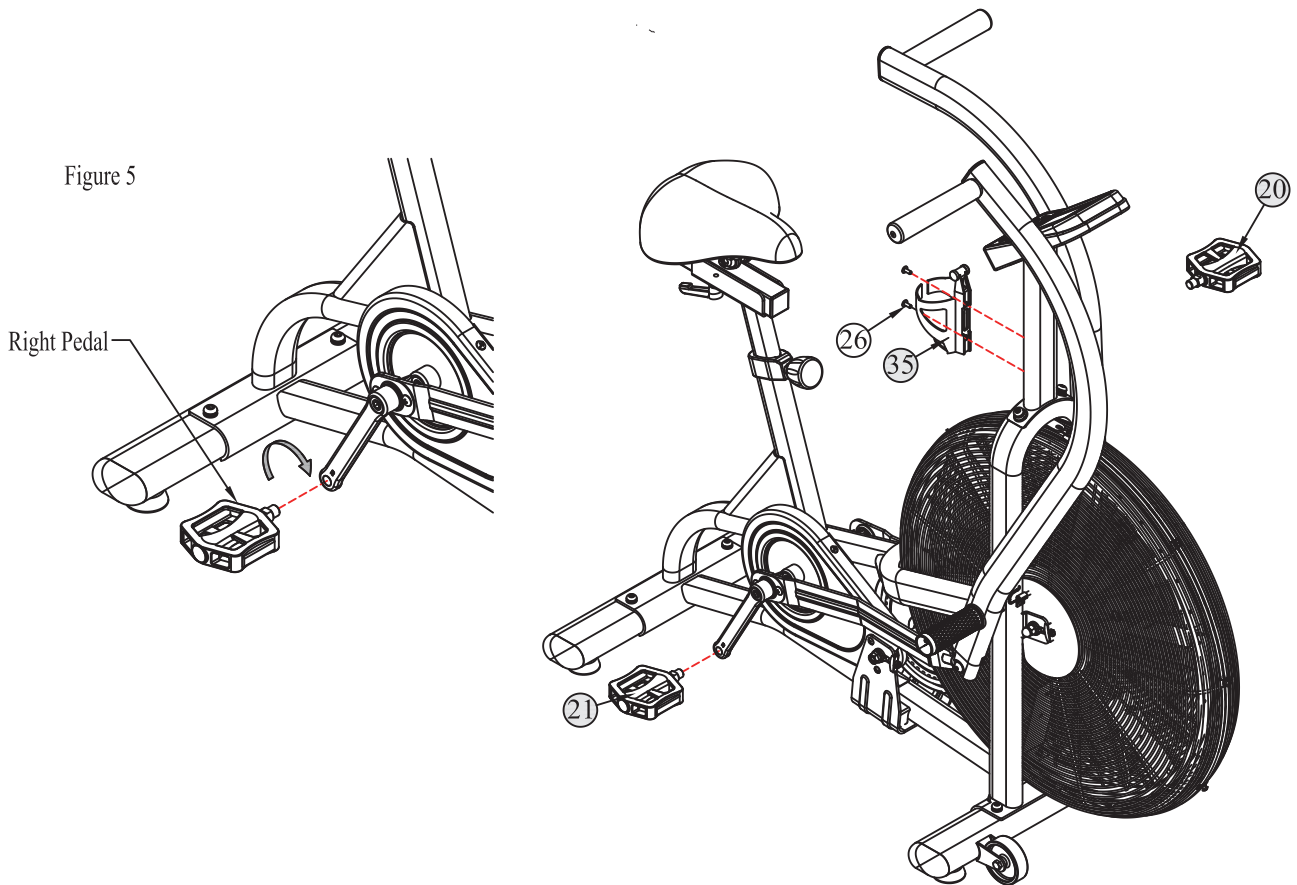

Assembly Hardware Required:

(*Assembly hardware may be preinstalled)

#26 Pan Head Screw*

Qty. 2

Assembly Description:

Assembly Note: The right and left pedals are appropriately marked (R) and (L). The threading orientation on the left pedal is reversed from the threading orientation on the right pedal. To avoid stripping of the threads on the pedals or crank arms, make sure to follow the proper assembly orientation.

- A) Assemble the **Right Pedal** (#20) to the **Right Crank Arm** on the **Main Base Assembly**. Thread the pedal on the crank arm (**clockwise**) and securely tighten with the pedal wrench (included). (Reference Figure #5)
- B) Assemble the **Left Pedal** (#21) to the **Left Crank Arm** on the **Main Base Assembly**. Thread the pedal onto the crank arm (**counterclockwise**) and securely tighten with the pedal wrench (included).
- C) Mount the **Bottle Cage** (#35) to the **Computer Mast** (#6) using 2-**Pan Head Screws** (#26).

Assembly Tip: Take time to review the additional information regarding computer operation, product maintenance, and warranty.

Congratulations !

You have successfully completed the assembly of this product and you are ready to start exercising toward a healthier lifestyle!

BASIC TROUBLESHOOTING TIPS

PROBLEM DESCRIPTION	SUGGESTED SOLUTION
NO DISPLAY	<ol style="list-style-type: none"> 1) CHECK BATTERY ORIENTATION: + / - 2) CHECK BATTERY VOLTAGE: (2) AA BATTERIES 1.5 VOLTS EACH 3) CHECK CABLE CONNECTIONS: MAKE SURE CONNECTIONS ARE SECURE AND IN THE CORRECT ORIENTATION. 4) CHECK CABLE ASSEMBLIES FOR DAMAGE: PINCH POINTS & POSSIBLE SHORTING OF WIRES. 5) CHECK FOR POSSIBLE COMPUTER DAMAGE: CRACKED DISPLAY WINDOW (BLACK SCREEN). <p>* If computer still fails to operate after checking these suggestions, contact us for technical support.</p>
PRODUCT WILL NOT SIT LEVEL	<ol style="list-style-type: none"> 1) USE LEVELERS ON THE BOTTOM OF THE STABILIZERS TO ADJUST EQUIPMENT TO UNEVEN SURFACES.
SEAT POST MOVEMENT	<ol style="list-style-type: none"> 1) MAKE SURE THE ADJUSTMENT KNOB IS LOCKED INTO A SEAT POST HOLE. 2) SECURELY TIGHTEN THE SEAT POST IN PLACE BY TURNING THE ADJUSTMENT KNOB.
PEDAL WOBBLE	<ol style="list-style-type: none"> 1) CHECK TO MAKE SURE PEDALS ARE INSTALLED CORRECTLY (ORIENTATION) AND MOUNTED FLUSH WITH THE CRANK ARMS. 2) LOOSEN THE PEDALS, CHECK FOR POSSIBLE CROSS-THREADING OF CRANK ARMS.
NO SPEED READING	<ol style="list-style-type: none"> 1) CHECK COMPUTER CONNECTION: MAKE SURE CONNECTORS ARE SECURE AND IN THE CORRECT ORIENTATION. 2) CHECK SPEED SENSOR. CONFIRM CABLE CONNECTION AND ALIGNMENT WITH MAGNET.

Make sure to reference the assembly steps & parts information in this manual when performing any troubleshooting.

If you experience other technical problems that are not listed or have additional questions, please check www.xebexfitness.com

EQUIPMENT MAINTENANCE

- Use a dampened soft-cloth to wipe equipment free of perspiration after each use. Avoid getting excessive moisture on computer or electronic components. Do not use abrasive cleaners or petroleum-based solvents to clean equipment.
- Do not remove drive train shrouds or attempt any technical service on equipment without consulting an authorized service representative.
- Regularly inspect product for loose assembly hardware and worn components.
- (If applicable) For added safety, unplug equipment from the wall socket when it is not being used.
- Use a product /exercise mat underneath equipment for protection of floors & carpets.
- (If applicable) Apply recommended component lubricants at the required time periods.
- Keep product assembly manual, purchase receipt, and service records in a safe storage place.
- (If applicable) Periodically check batteries for proper voltage output & replace as needed.
- Do not store or use equipment outdoors.
- Moving equipment:
 - Lift up the rear stabilizer and carefully tip the bike forward until the front stabilizer wheels touch the floor. **Do not** use the computer or pivot arms to move the unit. You may wish to lock the fan in place (which will keep the arms from moving), by turning the safety knob (referenced on page 7) until it makes contact with the fan wheel.

TRAINING FOR SUCCESS

How you start an exercise program depends on your physical condition. If you have been inactive for awhile or you have pre-existing health condition, you should start slowly. Initially you may only be able to exercise for a short amount of time using minimal resistance levels or weight loads.

Begin your desired training program slowly and gradually increase the amount of time you exercise. Apply realistic goals, that have been set by you or your physician. You should see sufficient gains in your personal fitness level within 6-8 weeks of continuous exercise, but do not be discouraged if it takes longer. It is very important to exercise at your own pace and become confident in obtaining your goals. It is also important to apply warm-up, stretching, and cool down periods with any exercise program.

As your fitness level increases, so will your confidence and sense of accomplishment. Regular exercise and a healthy diet will energize you and offer a sense of well-being.

XEBEX AIR BIKE
Maintenance Information

Service	Daily	Monthly	Quarterly	Annually
Clean/Dry Frame & Console w/ mild soap and cloth	X			
Inspect Unit for Noise or loose components	X			
Ensure Unit is level-Adjust Stabilizer Feet	X			
Tighten Crank & Bell Crank Bolts, Tighten Pedals		X		
Tighten Seat Bolts		X		
Tighten Handlebars		X		
Check and Tighten Linkage Arm Pivot points		X		
Change Console Batteries			X	
Lubricate Chain			X	
Inspect & Adjust Chain Tension if Needed			X	
Tighten Main Frame Bolts and Stabilizers				X

-See detailed instructions below

Use 3-in-1 OIL only. Do not use anything else!

1. Pedal Check: (Monthly):

Tighten the pedals with a 15mm wrench. The right side pedals will tighten “righty tighty” (clockwise) and the left side pedal will tighten “lefty tighty” (counter-clockwise).



2. Handlebar Assembly Check (Monthly)

Insert Screw Driver through peg of bike and tighten

3. Handlebar Assembly Check (Monthly):

Tighten the handlebar using a 22mm wrench. Tighten these down as tight as possible for both sides. Next, tighten handlebar assembly peg nut with 22mm socket wrench. *Note: There will be a little play in these arms after tightening but this is normal.*



XEBEX AIR BIKE
Maintenance Information

4. **Linkage Arm Check (Monthly):** Tighten the linkage bolts and nuts using a 6mm Allen wrench and 13mm wrench. Tighten these parts snug, but do not over tighten or keep tightening. *Note: There will be little play in these linkages after tightening, but this is normal. Some units will have a 22mm nut instead of a 13mm nut.*



5. **Chain Adjusting Check (Quarterly):** Check the two drive chains to make sure they are equally tight. Each chain should have just a slight flex to it, but it should also not be tightened too much. First check the main rear chain and adjust the tension if needed. Proper chain tension is about 3mm of movement up and down or a slight up and down movement. To adjust the chain, use the 15mm wrench to loosen the crank axle nut by rotating the wrench counter-clockwise. Once the axle nut is loosened use the 10mm wrench to turn the chain tensioner nut clockwise or counter-clockwise to adjust the tension. Repeat the process to the front tensioner and check the tension on each chain again. Adjust each section to get the proper alignment. Once you get the proper chain tension, tighten the 15mm axle nuts. Make sure the tension remains the same while tightening the axle nuts. If the tension is too much, loosen the 10mm nut slightly to release slack until it is equal.
6. **Clean and Lubricate the Chain (Quarterly):** The chain must be cleaned and lubricated at least every 50 hours. If the Air Bike is used in an institutional setting, then the chain must be cleaned and lubricated at least once a week. Use 3-in-1 Oil only, do not use anything else!

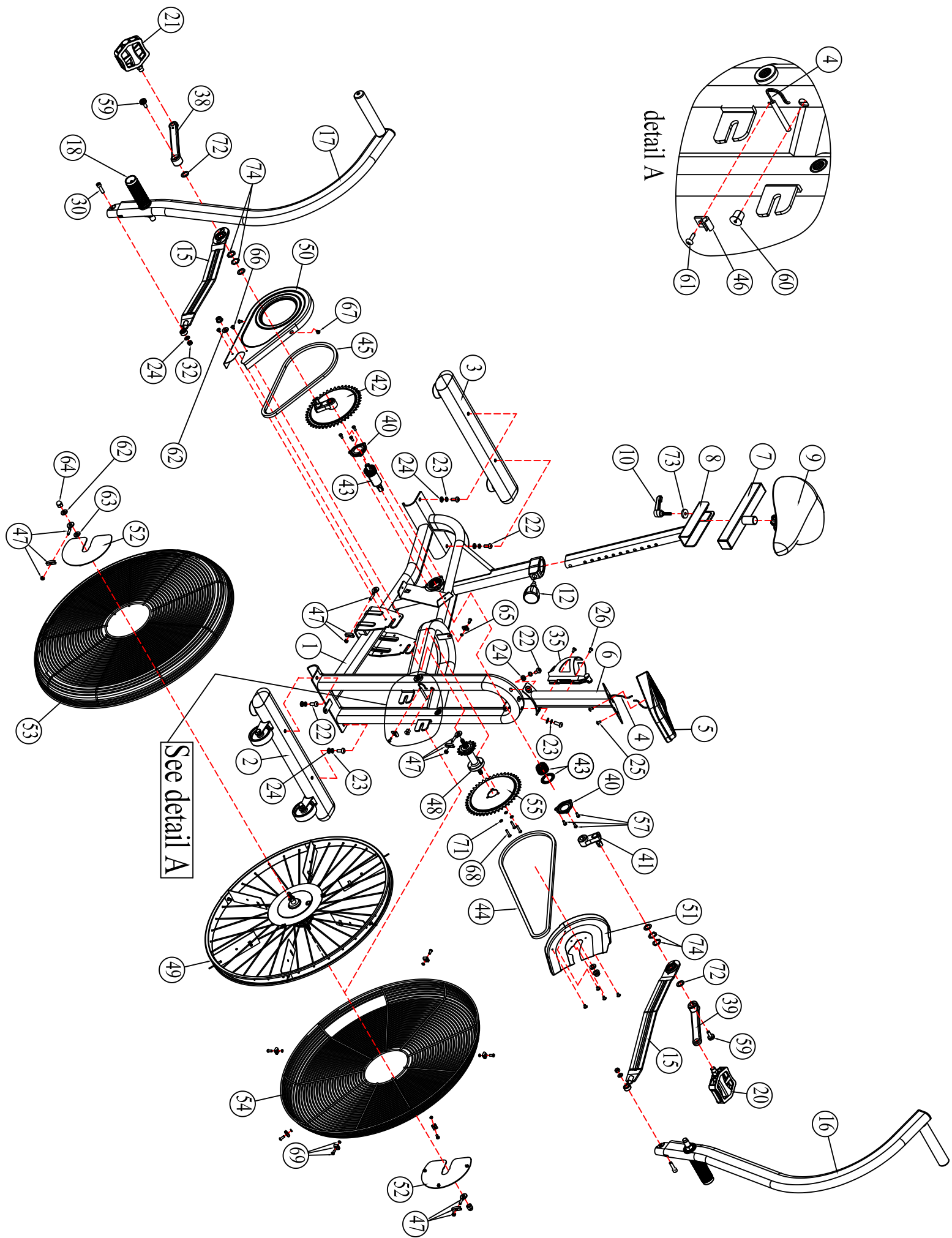

See detail A

detail A

Part List

PART DESCRIPTION	PART#	QTY	PART DESCRIPTION	PART#	QTY
FRAME	1	1PC	CHAIN	44	1PC
FRONT STABILIZER	2	1PC	CHAIN	45	1PC
REAR STABILIZER	3	1PC	SPEED SENSOR BRACKET ZEPHYR	46	1PC
COMPUTER WIRE	4	1PC	CHAIN TESIONER	47	4PAIR
COMPUTER	5	1PC	IDLER HUB	48	1PC
COMPUTER POST	6	1PC	WHEEL	49	1PC
SEAT TRACK	7	1PC	RIGHT CHAINGUARD	50	1PC
SEAT POST	8	1PC	LEFT CHAINGUARD	51	1PC
SEAT	9	1PC	SPOKE PROTECTOR	52	2PC
FIX HANDLEBAR	10	1PC	WHEEL CAGE RIGHT	53	1PC
KNOB	12	1PC	WHEEL CAGE LEFT	54	1PC
CONNECTING ARM PAIR	15	1PAIR	46T SPROCKET	55	1PC
LEFT LEVER ARM	16	1PC	HEX BOLT M5*10L	57	6PC
RIGHT LEVER ARM	17	1PC	CRANK BOLT	59	2PC
FOOT REST	18	2PC	SEMSOR STOPPER	60	1PC
LEFT PEDAL	20	1PC	SCREW M4*16L	61	1PC
RIGHT PEDAL	21	1PC	WASHER 10*20*3T	62	2PC
BUTTON HEAD ALLEN BOLT M8*20L	22	6PC	WASHER 10*19*1.5T	63	2PC
SPRING WASHER	23	12PC	DOME NUT 3/8"	64	2PC
WASHER 18*8.5*1.5T	24	14PC	WASHER 5*12*1T	65	1PC
BOLT M5*10L	25	2PC	SCREW M5*12L	66	4PC
PAN HEAD SCREW M5*10L	26	2PC	SCREW M5*10L	67	2PC
ALLEN BOLT M8	30	2PC	ALLEN BOLT M5*25L	68	3PC
NYLON NUT	32	2PC	SPEED NUT SET	69	6SET
BOTTLE CAGE	35	1PC	WASHER 5*10*1T	71	3PC
CRANK ARM RIGHT	38	1PC	WASHER 22*16*2T	72	2PC
CRANK ARM LEFT	39	1PC	WASHER 8.5*28*5	73	1PC
BRACKET	40	1PC	WASHER #16	74	4PC
LEFT CRANK ECCENTRIC	41	1PC			
RIGHT CRANK ECCENTRIC W/46T SPROCKET	42	1PC			
BOTTOM BRACKET SET	43	1SET			