



Round Table XL



 (704) 339-0785

 support@tvsetdesigns.com

 [@tvsetdesigns](https://twitter.com/tvsetdesigns)

 [/tvsetdesigns](https://facebook.com/tvsetdesigns)

 [#tvsetdesigns](https://instagram.com/tvsetdesigns)

 808 Tuckaseegee Road, Charlotte, NC 28208

Round Table XL

The Round Table XL is perfect for large round panel discussions. Comfortably seat six people around the six foot diameter acrylic top. This table's two-part top and locking casters let you easily move it where you need it.



Round Table XL Specifications

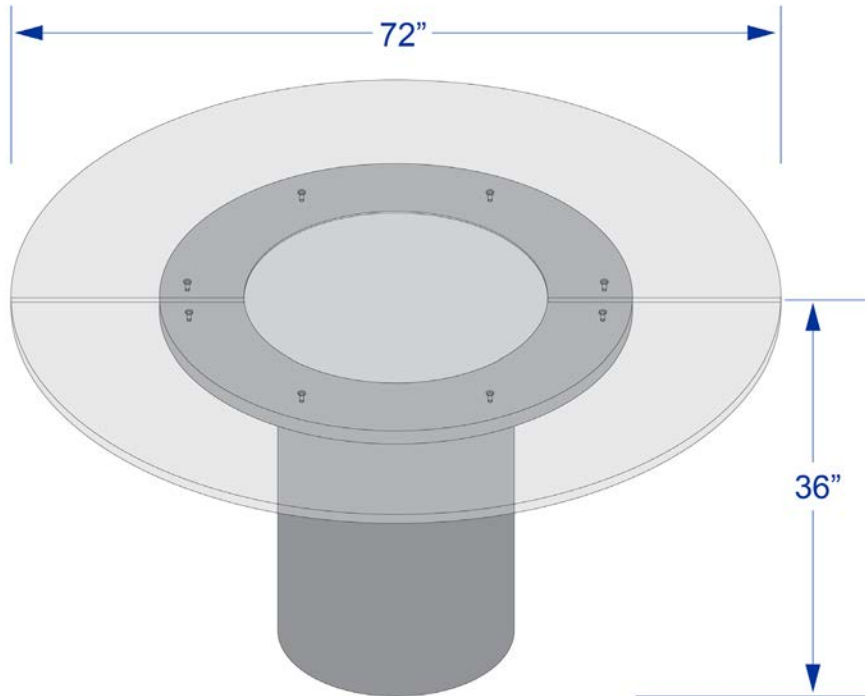

Assembled Footprint: 72" Diameter **Desk Weight:** 400 pounds

Crate Dimensions: 75"L x 64"W x 56"H **Crate Weight:** 835 pounds

Features

- Seats 6 people
- 1" thick acrylic top
- Choice of laminate finishes on the base
- Comes with locking casters
- Large pillar compartment to house equipment

Add-Ons

- Custom graphic
- Center cable pass-through
- Dual-zone RGBW tabletop lighting with DMX compatible multi-channel lighting controller

Secret Compartment... Don't Tell Anyone



Cable Pass Through



Cable Pass-Through

A cable pass-through in the tabletop allows you to easily route cables for wired microphones and other devices. The large hidden compartment in the table base is great for hiding unsightly electronic components without the need to stash them elsewhere on set.

Options:

- Large format graphic
- Center cable pass-through

\$12,985 with freight



TVsetdesigns.com LLC
 808 Tuckaseegee Road
 Charlotte, NC 28208-4435

Voice:704-339-0785 Fax:704-339-0545
 support@tvsetdesigns.com

Quote

Date	Estimate #
1/1/2024	DRndXLGfx24

Billing Company Name / Address:

EXAMPLE QUOTE ONLY
 DO NOT SUBMIT A P.O.
 ALL QUOTES ARE JOB SPECIFIC



Customer Phone	Customer E-mail	Terms	PO Number
	support@tvsetdesigns.com		

Description	Qty	Rate	U/M	Total
Project to build a XL Round Table Desk with a center graphic				
Round Table Desk 72" diameter, 1" thick clear acrylic top, fixed height 30" - 36", laminate pedestal base, castors and stoppers, approx 400 pounds. Note: Top is built from 2 pieces of acrylic	1	10,023.00	ea	10,023.00
Round Table Desk XL Graphic, up to 60" dia image, etched/cut into the 1" acrylic top, cut out, or printed and applied - Includes renderings with up to 2 revisions No lighting	1	1,543.00	ea	1,543.00
Ship XL Round Table Desk with 2 Crates Strapped - Approx 75"L X 64"W X 56"H 835lbs via LTL furniture class freight **Client provides unloading and install labor Quotes for installation or dedicated truck delivery are available upon request	1	1,419.00	ea	1,419.00
Typical production time for this project is 6-8 weeks. Construction does not begin until payment has been received, all design decisions have been approved, and finishes have been selected				
Payment terms: 100% Deposit Due to start construction In lieu of deposit payments, POs are accepted only from state or federal school districts, collegiate/university institutions, and U.S. government organizations				
Please note that sales tax may be added at the time of invoicing. If we do not receive the appropriate exemption or resale certificate, we must charge tax in certain states Total sales tax calculated by AvaTax		0.00		0.00

This pricing will be honored until the end of the calendar year that the quote was issued. All freight is LTL service and the client is responsible for unloading and installation unless otherwise indicated above. Image use rights are the responsibility of the end user.			Total	\$12,985.00
---	--	--	--------------	-------------

Tabletop Lighting



RGBW Tabletop Lighting

RGBW tabletop lighting lets you add color to the 1" acrylic top. This feature comes with a multi-channel DMX controller allowing you to easily adjust the brightness and choose from thousands of colors for your edge lighting.

Options:

- Center graphic
- Dual-zone RGBW tabletop lighting

\$17,139 with freight



TVsetdesigns.com LLC
 808 Tuckaseegee Road
 Charlotte, NC 28208-4435

Voice:704-339-0785 Fax:704-339-0545
 support@tvsetdesigns.com

Quote

Date	Estimate #
1/1/2024	DRndXLLit24

Billing Company Name / Address:

EXAMPLE QUOTE ONLY
DO NOT SUBMIT A P.O.
ALL QUOTES ARE JOB SPECIFIC



Customer Phone	Customer E-mail	Terms	PO Number
	support@tvsetdesigns.com		

Description	Qty	Rate	U/M	Total
Project to build a XL Round Table Desk with a center graphic and dual-zone lighting				
Round Table Desk 72" diameter, 1" thick clear acrylic top, fixed height 30" - 36", laminate pedestal base, castors and stoppers, approx 400 pounds. Note: Top is built from 2 pieces of acrylic	1	10,023.00	ea	10,023.00
Round Table Desk XL Lit Graphics, up to 60" diameter image etched/cut into the 1" acrylic top, cut out, or printed and applied. RGBW dual-zone lighting, ACM light source cover, and install. Includes renderings up to 2 revisions	1	5,360.00	ea	5,360.00
Multi-channel DMX Controller	1	337.00	ea	337.00
Ship XL Round Table Desk with 2 Crates Strapped - Approx 75"L X 64"W X 56"H 835lbs via LTL furniture class freight **Client provides unloading and install labor Quotes for installation or dedicated truck delivery are available upon request	1	1,419.00	ea	1,419.00
Typical production time for this project is 6-8 weeks. Construction does not begin until payment has been received, all design decisions have been approved, and finishes have been selected				
Payment terms: 100% Deposit Due to start construction In lieu of deposit payments, POs are accepted only from state or federal school districts, collegiate/university institutions, and U.S. government organizations				
Please note that sales tax may be added at the time of invoicing. If we do not receive the appropriate exemption or resale certificate, we must charge tax in certain states Total sales tax calculated by AvaTax		0.00		0.00

This pricing will be honored until the end of the calendar year that the quote was issued. All freight is LTL service and the client is responsible for unloading and installation unless otherwise indicated above. Image use rights are the responsibility of the end user.			Total	\$17,139.00
---	--	--	--------------	-------------