



5 Piece Modular Desk



 (704) 339-0785

 support@tvsetdesigns.com

 [@tvsetdesigns](https://twitter.com/tvsetdesigns)

 [/tvsetdesigns](https://facebook.com/tvsetdesigns)

 [#tvsetdesigns](https://instagram.com/tvsetdesigns)

 808 Tuckaseegee Road, Charlotte, NC 28208

5 Piece Modular Desk

The 5 Piece Modular Desk is the ultimate in versatility. In addition to the five rearrangeable modules, Smart TVs and RGBW LED lit endcaps let you easily change graphics and light the desk in thousands of colors.

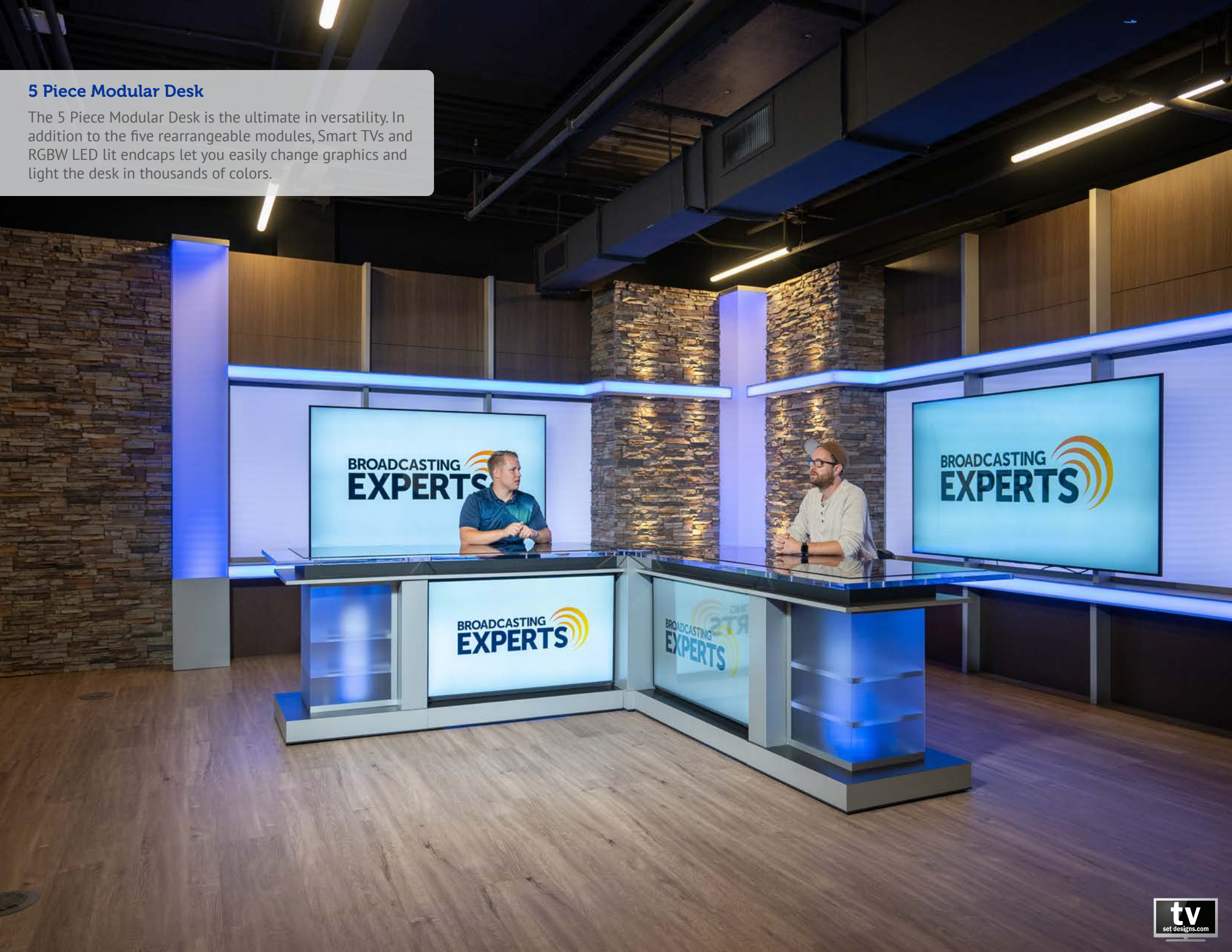

How It Works

Three Simple Pieces

The 5 Piece Modular Desk is made of three easily configurable pieces: two RGBW LED lit endcaps, two main modules, and a 90° corner module with a rounded edge. All modules include locking casters and bolt together. This allows each module to stand alone, or easily move around to utilize the multiple configurations. Complete your studio with the 5 Piece Modular Desk, or add additional modules to make a desk of epic proportions.

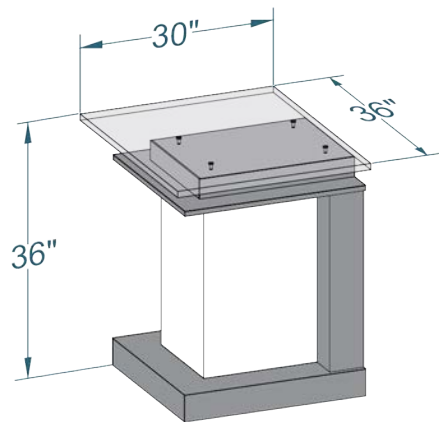

Weight: 175 pounds
Footprint: 30" W x 36" D

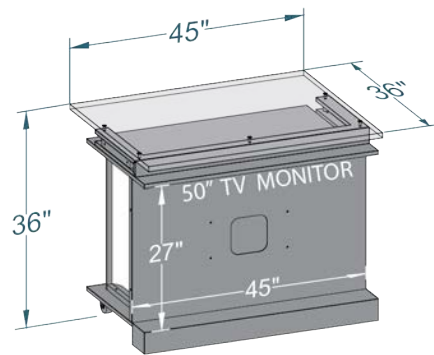

Weight: 185 pounds
Footprint: 45" W x 36" D

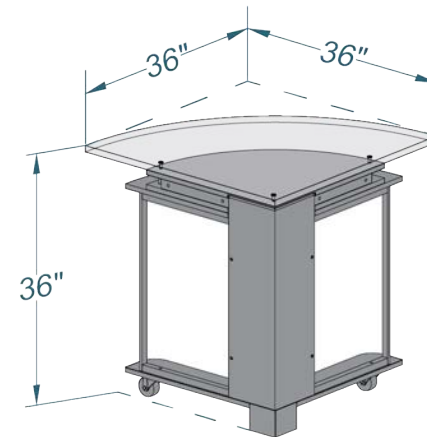

Weight: 150 pounds
Footprint: 36" W x 36" D

One Design, Many Configurations



The 5 Piece Modular Desk is easy to reconfigure. Each module is on locking castors and bolts together so you can assemble the desk to fit your needs. Use it in different sized studios, with multiple presenters, or change it up to create a fresh look for your broadcast.

Maybe you want a bigger desk and more options? You can purchase extra pieces to unlock endless possibilities. With a few extra pieces you can create a U-shaped desk perfect for debates and moderated competitions. Add more center modules to create a desk for a large convention panel.

With your imagination the options are endless.



Removable Top Covers

Black Fabric Top

Removable 1/8" Black Fabric Overlay

- Eliminates glare
- A must have for use with a green screen
- Hides items placed on shelf
- Protects attached acrylic top
- Five separate panels
- Can be used in any configuration



Black Plexi Top

Removable 1/8" Black Plexi Overlay

- Sleek black finish
- Dresses up the modular desk
- Hides iPads & tablets placed on shelf
- Protects attached acrylic top
- Five separate panels
- Can be used in any configuration



5 Piece Modular Desk Specifications

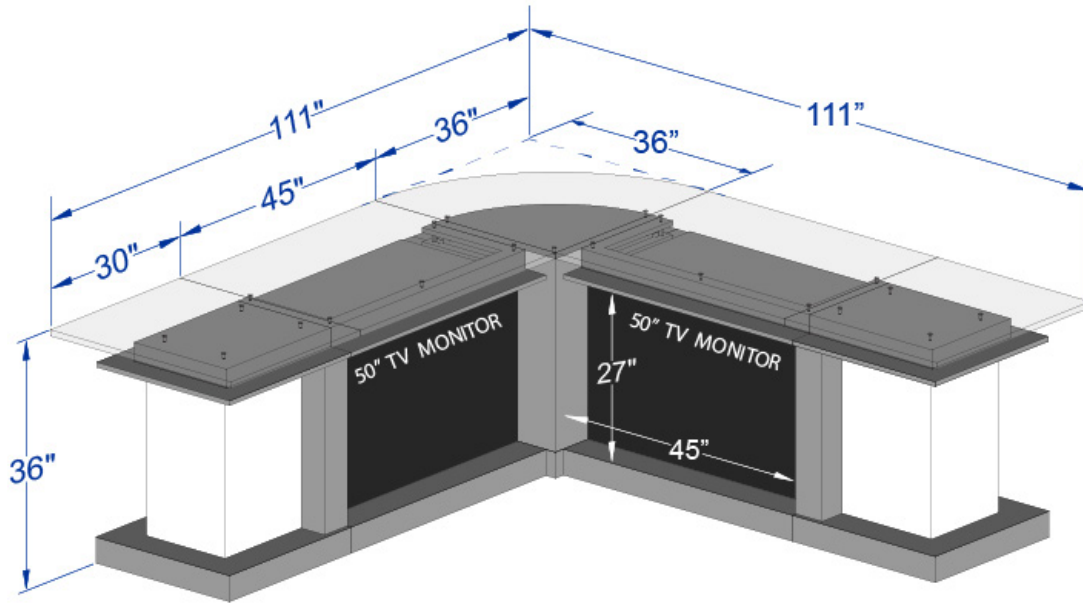

Desk Ships in Five Crates | **Crate Dimensions:** 50"L x 40"W x 43"H

Endcap Crate (2) Weight: 340 lbs | **Center Crate (2) Weight:** 350 lbs | **Corner Crate (1) Weight:** 270 lbs

Features

- Two endcaps, two main modules, and one corner piece
- Seats 6 people
- Locking casters for easy reconfiguration
- Built-in 50" Smart TVs with HDMI and USB ports
- Easily add video, motion graphics, or branding
- Video Wall Controller syncs images across monitors
- Strong and lightweight tubular steel frame
- RGBW LED lit endcaps
- Multi-channel controller to adjust thousands of colors
- DMX lighting compatible with your studio's controls
- Center modules have built-in shelves to hold iPads, etc

Desk Back



5 Piece Modular Desk

The 5 Piece Modular Desk standard model has a 1" thick acrylic top.





TVsetdesigns.com LLC
 808 Tuckaseegee Road
 Charlotte, NC 28208-4435

Voice:704-339-0785 Fax:704-339-0545
 support@tvsetdesigns.com

Quote

Date	Estimate #
1/1/2024	D5PcMod24

Billing Company Name / Address:

EXAMPLE QUOTE ONLY
DO NOT SUBMIT A P.O.
ALL QUOTES ARE JOB SPECIFIC



Customer Phone	Customer E-mail	Terms	PO Number
	support@tvsetdesigns.com		

Description	Qty	Rate	U/M	Total
Project to build a Five Piece Modular Desk with RGBW columns, 2 face monitors, and basic video wall controller				
Modular Desk 5 Piece - 2 main modules, 1 corner, 2 lit endcaps, 111" L x 111" W x 36"D x 36"H, 1" clear acrylic tops, RGBW lighting, multi-channel controller, locking castors, approx 840 pounds	1	27,572.00	ea	27,572.00
Monitor 50" 4K Smart TV, wall mount, and install on desk face	2	1,056.00	ea	2,112.00
Basic Video Wall Controller HDMI 1 - 3840x2160 Input x 2 HDMI 1920x1080 Outputs	1	525.00	ea	525.00
Ship Five Piece Modular Desk with 5 Crates - each approx 49"L X 49"W X 49"H 350 lbs via LTL furniture class freight **Client provides unloading and install labor Quotes for installation or dedicated truck delivery are available upon request	1	3,125.00	set	3,125.00
Typical production time for this project is 6-8 weeks. Construction does not begin until payment has been received, all design decisions have been approved, and finishes have been selected				
Payment terms: 100% Deposit Due to start construction In lieu of deposit payments, POs are accepted only from state or federal school districts, collegiate/university institutions, and U.S. government organizations				
Please note that sales tax may be added at the time of invoicing. If we do not receive the appropriate exemption or resale certificate, we must charge tax in certain states Total sales tax calculated by AvaTax		0.00		0.00

This pricing will be honored until the end of the calendar year that the quote was issued. All freight is LTL service and the client is responsible for unloading and installation unless otherwise indicated above. Image use rights are the responsibility of the end user.	Total	\$33,334.00
-------------------------------------------------------------------------------------------------------------------------------------------------------------------------------------------------------------------------------------------------------------------------------	--------------	--------------------

Additional Examples



5 Piece Modular Desk with Black Plexi Top

The 5 Piece Modular Desk with an 1/8" removable black plexiglass overlay looks sleek and hides tablets on the built-in shelf.

Options:

- Two 50" LED Monitors
- Video Wall Controller syncs images across monitors
- Removable Plexi Overlay

\$34,060 with freight

5 Piece Modular Desk with Black Fabric Top

The 5 Piece Modular Desk with an 1/8" removable black fabric overlay eliminates glare and is essential for use with green screens.

Options:

- Two 50" LED Monitors
- Video Wall Controller syncs images across monitors
- Removable Fabric Top

\$34,456 with freight

