

8' Curve Fabric Wall

The Curved Fabric Set Wall offers a versatile and vibrant printed fabric wall that will transform your broadcast set, event space, or trade show. Its 30mm aluminum tube frame construction is durable and lightweight, while the self-supporting design offers easy setup without the need for additional support. Stretch fabric graphics are hand-sewn, durable and dry-cleanable.



FEATURES:

- Lightweight 30mm aluminum tube frame with snap button assembly
- Easy to store and ship
- Quick to set up
- Kit includes: one frame, one dye-sublimated zipper pillowcase graphic, and one wheeled molded storage case

DIMENSIONS:

Hardware	Graphic
<p>Assembled unit: 90.3413"w x 92.0591"h x 18.5939"d</p> <p>Approximate weight (includes graphic): 20 lbs / 9.07 kgs</p>	<p>Total visual area: 98"w x 92"h</p> <p>Please be sure to include 2" bleed around the perimeter.</p>
Shipping	
<p>Shipping dimensions: 1 OCL case: 19"L x 19"W x 57"H</p> <p>Approximate shipping weight (with case): 40 lbs</p>	

ADDITIONAL INFORMATION:

Graphic material:
Dye-sublimated zipper pillowcase fabric

Parts Included		
Part Label	Qty	Part Code
90 DEGREE ELBOW JOINT FOR 30MM TUBING	x4	TC-30-90
T JUNCTION FOR 30MM TUBING	x4	TC-30-T
4 WAY JUNCTION FOR 30MM TUBING	x1	TC-30-X
30MM CURVED TUBE SECTION	x6	WH8-10-01
1114MM X 30MM TUBE	x6	WH10-01-T2
FABRIC GRAPHIC	x1	WH8-01-G

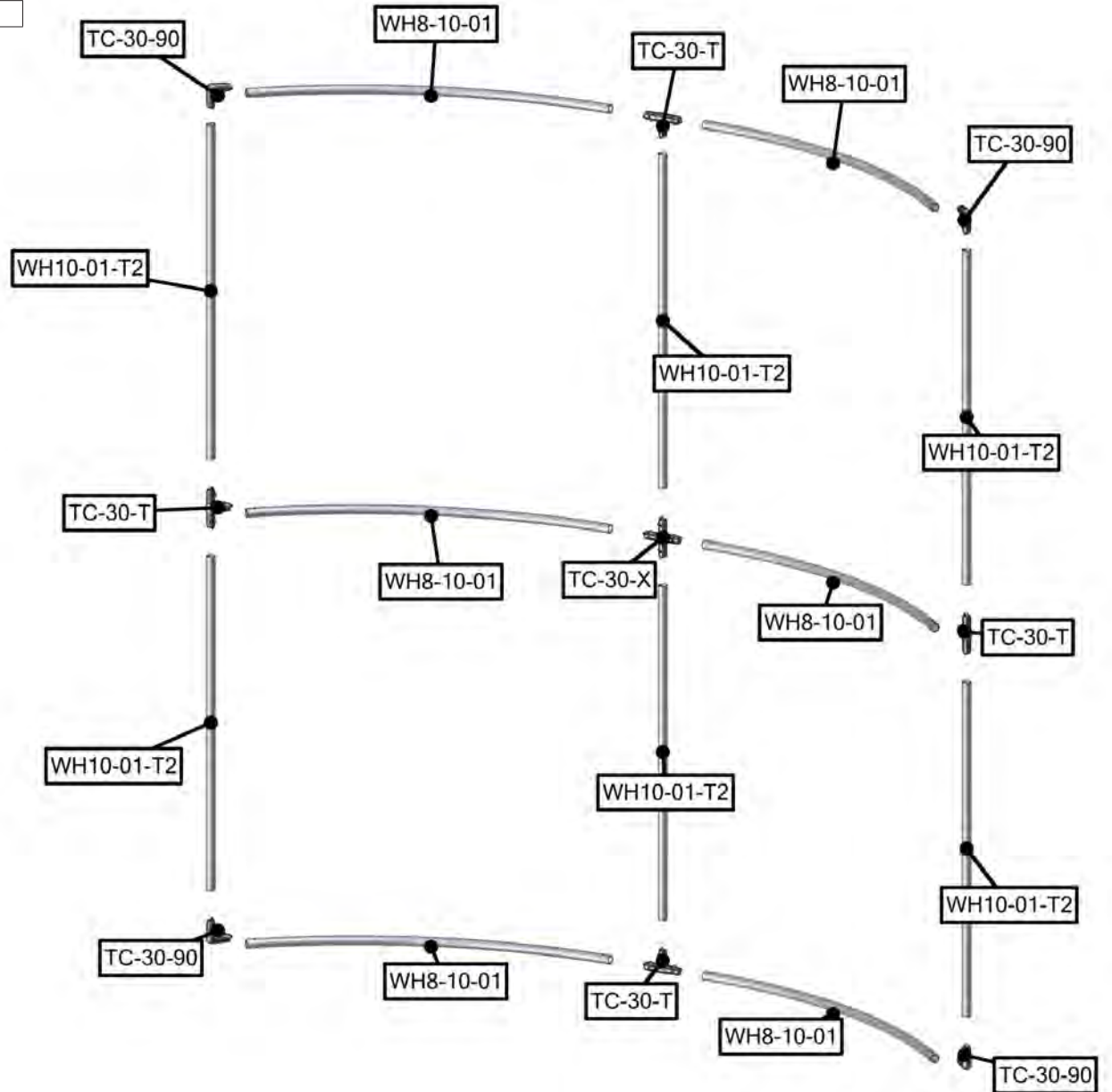

STEP 1: ASSEMBLE FRAME

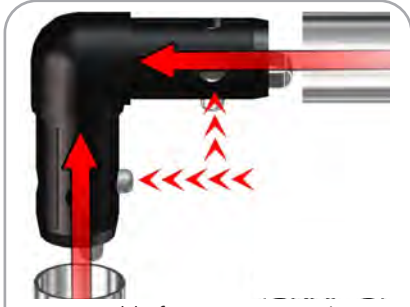

Assemble frame corners using TC-30-90. Label codes will be on backside of tube. It is best to assemble frame laying flat.

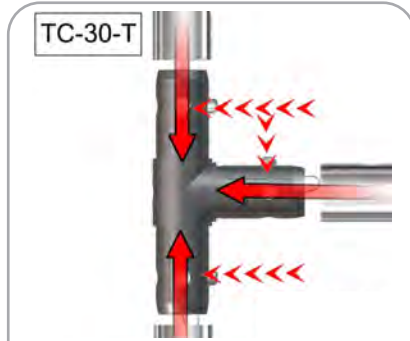

Using TC-30-T junction to connect sides of frame to middle section.

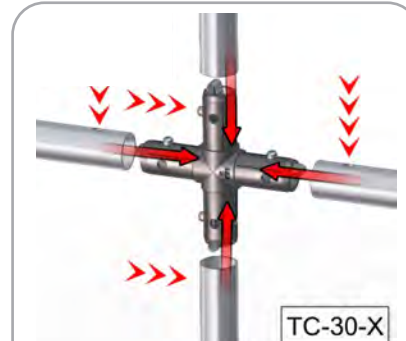

Using TC-30-X junction to connect frame in the middle.

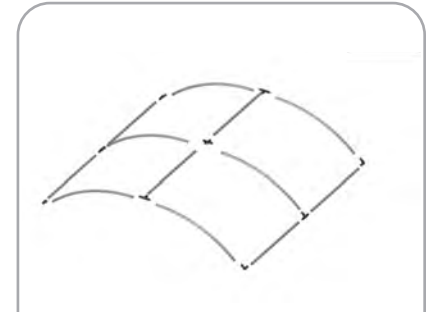

Frame is attached once all connections are made.

STEP 2: ATTACH GRAPHIC

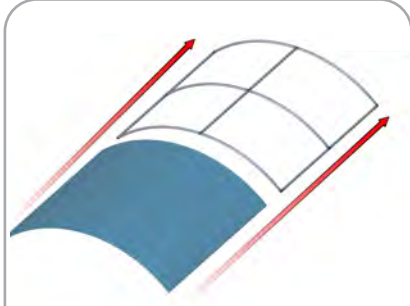

Slide graphic over top of frame.

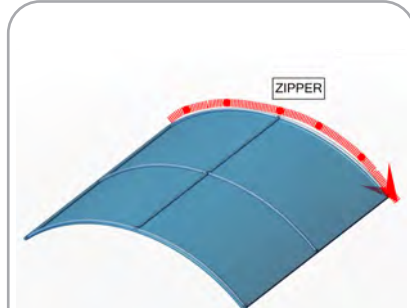

Zip graphic closed along bottom.

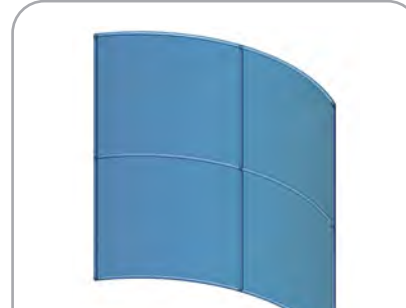

Stand unit upright.