

PLANNING DESK

PT-72P & PT-72M SERIES TABLES ASSEMBLY INSTRUCTIONS

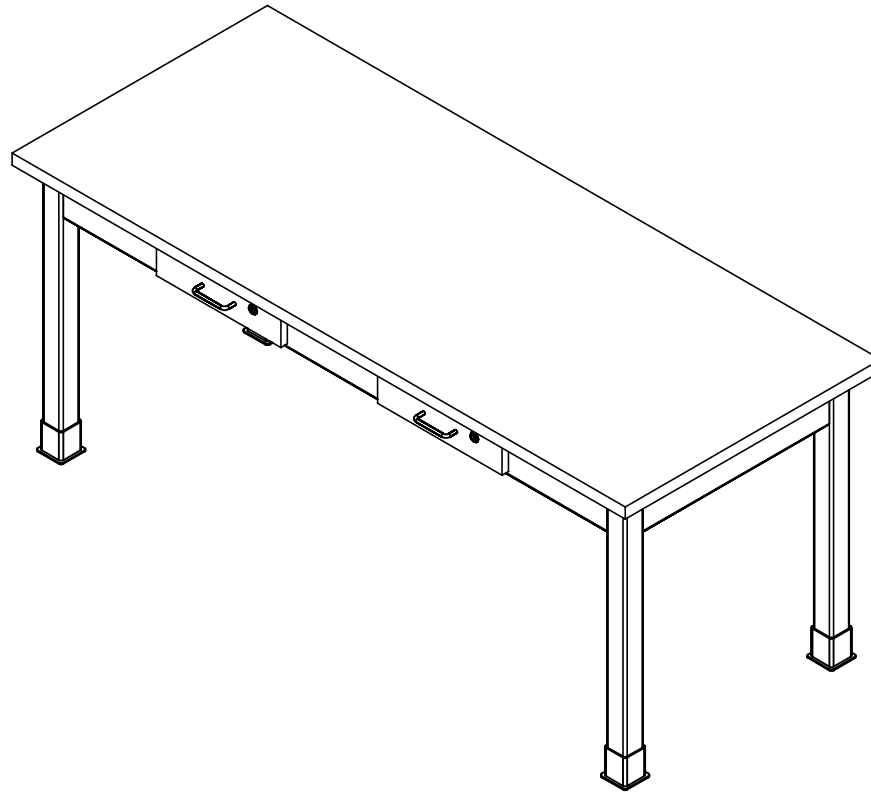

NOTE:

1. MODEL VIEWS MAY NOT REPRESENT EXACT MODEL PURCHASED

ALL DIMENSIONS ARE IN INCHES UNLESS NOTED OTHERWISE	DWN BY:	EMR	DATE DWN:	10/24/14
DECIMALS: $\forall = \pm .030$	APR BY:		DATE APR:	
XX = $\pm .020$	APR BY:		DATE APR:	
XXX = $\pm .010$	APR BY:		DATE APR:	
ANGLES: = $\pm 1^{\circ}$	APR BY:		DATE APR:	
CABINET SQUARENESS: = $\pm .0625$	APR BY:		DATE APR:	

CONFIDENTIAL:
ALL DESIGN RIGHTS RESERVED
THE INFORMATION, DATA, DESIGN, AND DRAWINGS EMBODIED IN THIS DOCUMENT AND ALL REPRODUCTIONS THEREOF ARE THE EXCLUSIVE PROPERTY OF DIVERSIFIED WOODCRAFTS, INC.

THESE DOCUMENTS ARE SUPPLIED WITH THE UNDERSTANDING THAT THEY WILL NOT BE DISCLOSED TO THIRD PARTIES WITHOUT WRITTEN CONSENT OF DIVERSIFIED WOODCRAFTS, INC. ANY REPRODUCTION IN PART OR WHOLE WITHOUT WRITTEN CONSENT IS SUBJECT TO LEGAL ACTION.



300 South Krueger Street
Suring, WI 54174
diversifiedwoodcrafts.com

TITLE:
PLANNING DESK
ASSEMBLY INSTRUCTIONS

REV.	DESCRIPTION	DATE	NAME	ECN NO.
A	CREATED ASSEMBLY INSTRUCTIONS	10/24/14	EMR	-
REVISION LEVEL				

DRAWING NUMBER:	SCALE:	SHEET:	REVISION:
PT-72P & PT-72M SERIES TABLES	NTS	1 OF 7	REV A

TOOLS REQUIRED

1/2" WRENCH

1/2" SOCKET AND TORQUE WRENCH - OPTIONAL

ASSEMBLY COMPONENTS

ITEMS INCLUDED	PART #	PART DESCRIPTION	QTY
TOP AND APRON ASSEMBLY	N/A	TOP ASSEMBLY (FACTORY ASSEMBLY) - STYLE VARIES	1
LEGS	501100	LEG,MPL 2.25X2.25X28.25	4
LEG HARDWARE	520001-4	LEG HARDWARE KIT, 4 LEGS	1
LEG BOOTS	100076	LEG BOOT, BLK RUBBER	4

NOTE:

1. COMPONENTS VARY WITH STYLE OF TABLE PURCHASED.
 - 1.1. TOP STYLES:
 - 1.1.1. PLASTIC LAMINATE (P) OR MAPLE (M).

ALL DIMENSIONS ARE IN INCHES UNLESS NOTED OTHERWISE DECIMALS: .X = ± .030 .XX = ± .020 .XXX = ± .010 ANGLES: = ± 1° CABINET SQUARENESS = ± .0625	DWN BY: EMR	DATE DWN: 10/24/14
	APR BY:	DATE APR:
	APR BY:	DATE APR:



300 South Krueger Street
Suring, WI 54174
diversifiedwoodcrafts.com

CONFIDENTIAL:
ALL DESIGN RIGHTS RESERVED
THE INFORMATION, DATA, DESIGN, AND DRAWINGS EMBODIED IN THIS DOCUMENT AND ALL REPRODUCTIONS THEREOF ARE THE EXCLUSIVE PROPERTY OF DIVERSIFIED WOODCRAFTS, INC.

TITLE:
PLANNING DESK
TOOLS AND ASSEMBLY COMPONENTS

THESE DOCUMENTS ARE SUPPLIED WITH THE UNDERSTANDING THAT THEY WILL NOT BE DISCLOSED TO THIRD PARTIES WITHOUT WRITTEN CONSENT OF DIVERSIFIED WOODCRAFTS, INC. ANY REPRODUCTION IN PART OR WHOLE WITHOUT WRITTEN CONSENT IS SUBJECT TO LEGAL ACTION.

DRAWING NUMBER:	SCALE:	SHEET:	REVISION:
PT-72P & PT-72M SERIES TABLES	NTS	2 OF 7	REV A

REV.	DESCRIPTION	DATE	NAME	ECN NO.
A	CREATED ASSEMBLY INSTRUCTIONS	10/24/14	EMR	-
REVISION LEVEL				

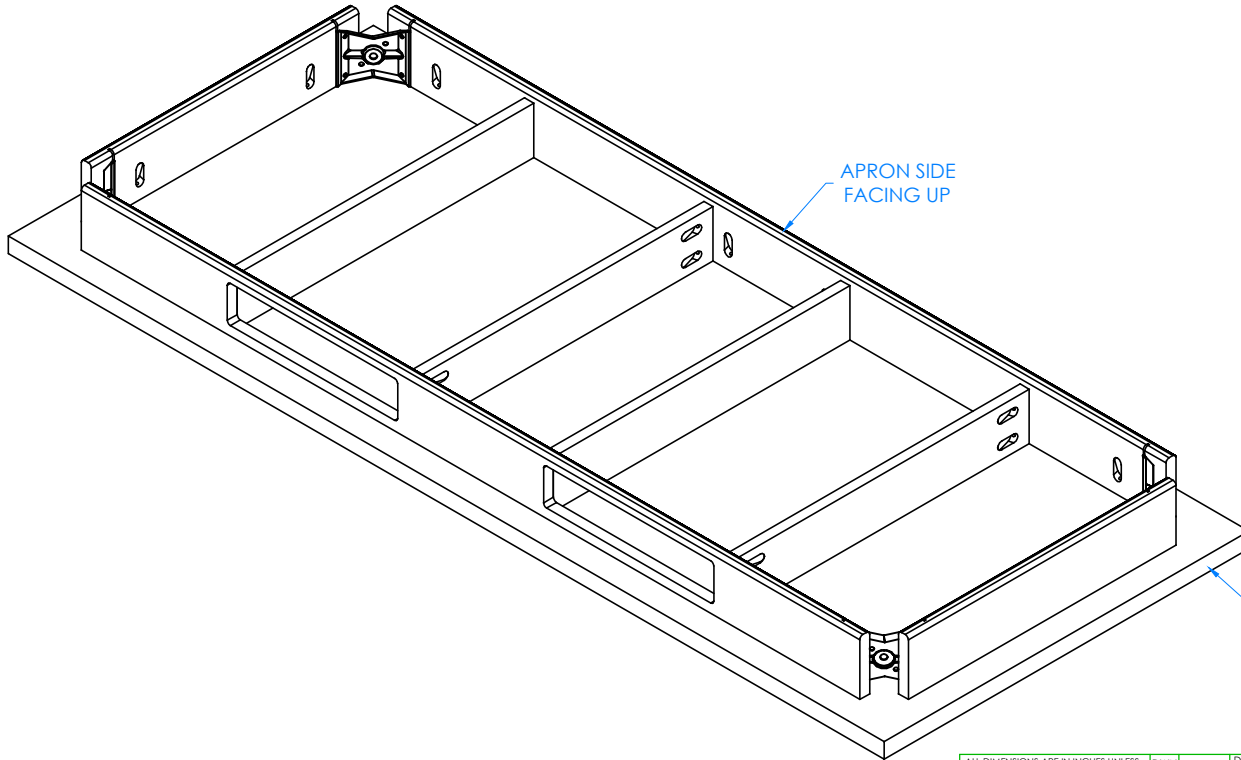

APRON SIDE
FACING UP

STEP 1:

- LAY TOP ASSEMBLY ON FLOOR,
WITH APRON SIDE FACING UP.

****NOTE****
BE SURE TOP ASSEMBLY IS
ON A CLEAN SURFACE
TO PREVENT DAMAGE

NOTE:

1.

ALL DIMENSIONS ARE IN INCHES UNLESS NOTED OTHERWISE	DWN BY:	EMR	DATE DWN:	10/24/14
DECIMALS: X = ± .030	APR BY:		DATE APR:	
XX = ± .020	APR BY:		DATE APR:	
XXX = ± .010	APR BY:		DATE APR:	
ANGLES: = ± 1°	APR BY:		DATE APR:	
CABINET SQUARENESS: = ± .0625	APR BY:		DATE APR:	

CONFIDENTIAL:
ALL DESIGN RIGHTS RESERVED
THE INFORMATION, DATA, DESIGN, AND DRAWINGS EMBODIED IN THIS DOCUMENT AND ALL REPRODUCTIONS THEREOF ARE THE EXCLUSIVE PROPERTY OF DIVERSIFIED WOODCRAFTS, INC.

THESE DOCUMENTS ARE SUPPLIED WITH THE UNDERSTANDING THAT THEY WILL NOT BE DISCLOSED TO THIRD PARTIES WITHOUT WRITTEN CONSENT OF DIVERSIFIED WOODCRAFTS, INC. ANY REPRODUCTION IN PART OR WHOLE WITHOUT WRITTEN CONSENT IS SUBJECT TO LEGAL ACTION.



300 South Krueger Street
Suring, WI 54174
diversifiedwoodcrafts.com

TITLE:
PLANNING DESK
ASSEMBLY INSTRUCTION

REV.	DESCRIPTION	DATE	NAME	ECN NO.
A	CREATED ASSEMBLY INSTRUCTIONS	10/24/14	EMR	-
REVISION LEVEL				

DRAWING NUMBER:	SCALE:	SHEET:	REVISION:
PT-72P & PT-72M SERIES TABLES	NTS	3 OF 7	REV A

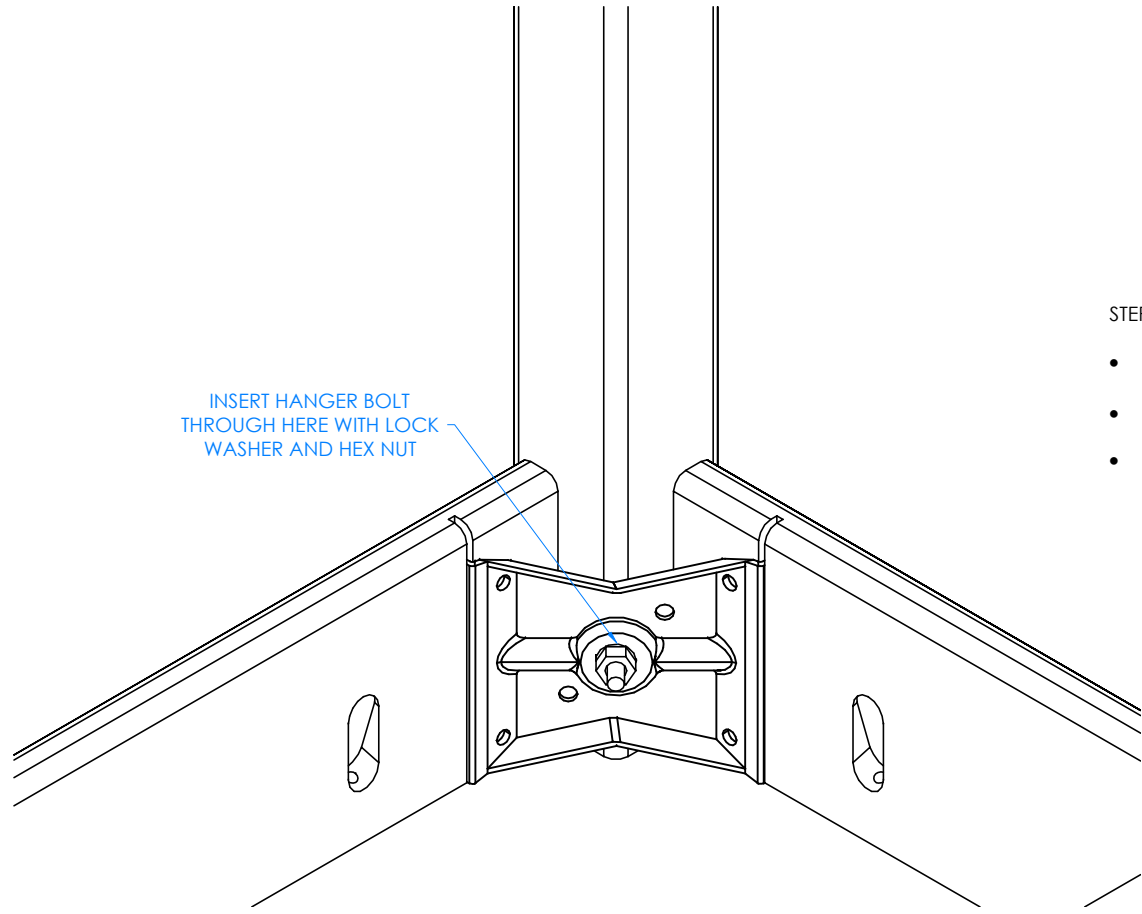

INSERT HANGER BOLT THROUGH HERE WITH LOCK WASHER AND HEX NUT

CLOSE UP OF CORNER LEG ASSEMBLY

STEP 2:

- INSERT THE HANGER BOLT ON ONE LEG THROUGH THE CORNER BRACKET AND INSERT THE LOCK WASHER AND HEX NUT.
- TIGHTEN NUT USING A 1/2" WRENCH OR 1/2" SOCKET AND TORQUE WRENCH, TO A MINIMUM OF 12FT LBS BUT NOT TO EXCEED 17FT LBS.
- REPEAT ON OTHER LEGS.

NOTE:

1.

ALL DIMENSIONS ARE IN INCHES UNLESS NOTED OTHERWISE	DWN BY:	EMR	DATE DWN:	10/24/14
DECIMALS: .X = ± .030	APR BY:		DATE APR:	
.XX = ± .020	APR BY:		DATE APR:	
.XXX = ± .010	APR BY:		DATE APR:	
ANGLES: = ± 1°	APR BY:		DATE APR:	
CABINET SQUARENESS: = ± .0625	APR BY:		DATE APR:	

CONFIDENTIAL:
ALL DESIGN RIGHTS RESERVED
THE INFORMATION, DATA, DESIGN, AND DRAWINGS EMBODIED IN THIS DOCUMENT AND ALL REPRODUCTIONS THEREOF ARE THE EXCLUSIVE PROPERTY OF DIVERSIFIED WOODCRAFTS, INC.

THESE DOCUMENTS ARE SUPPLIED WITH THE UNDERSTANDING THAT THEY WILL NOT BE DISCLOSED TO THIRD PARTIES WITHOUT WRITTEN CONSENT OF DIVERSIFIED WOODCRAFTS, INC. ANY REPRODUCTION IN PART OR WHOLE WITHOUT WRITTEN CONSENT IS SUBJECT TO LEGAL ACTION.



300 South Krueger Street
Suring, WI 54174
diversifiedwoodcrafts.com

TITLE:
PLANNING DESK
ASSEMBLY INSTRUCTION

REV.	DESCRIPTION	DATE	NAME	ECN NO.
A	CREATED ASSEMBLY INSTRUCTIONS	10/24/14	EMR	-
REVISION LEVEL				

DRAWING NUMBER:	SCALE:	SHEET:	REVISION:
PT-72P & PT-72M SERIES TABLES	NTS	4 OF 7	REV A

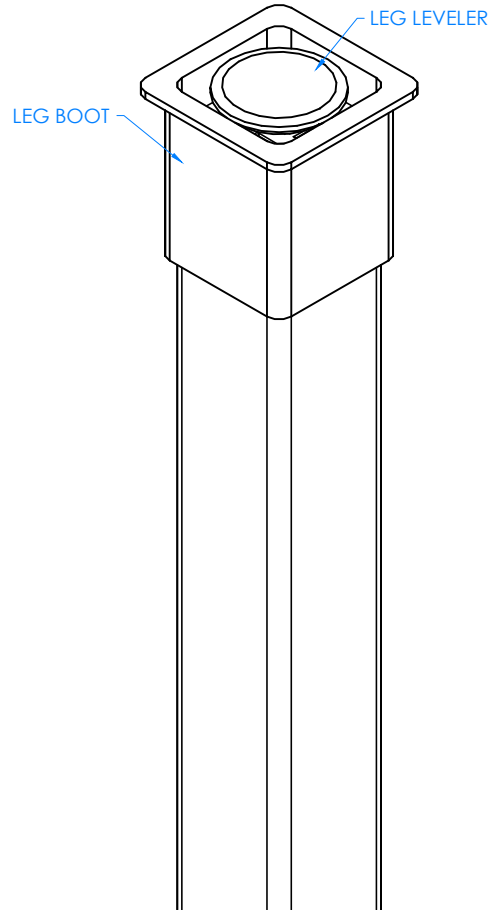

STEP 3:

- SLIDE LEG BOOTS ONTO LEGS WITH FLARED END TOWARD BOTTOM OF LEG.
- SCREW LEG LEVELERS INTO T-NUT ON BOTTOM OF LEG.

CLOSE UP OF LEG BOOT AND LEVELER ASSEMBLY

NOTE:

1.

ALL DIMENSIONS ARE IN INCHES UNLESS NOTED OTHERWISE	DWN BY:	EMR	DATE DWN:	10/24/14
DECIMALS: $W = \pm .030$	APR BY:		DATE APR:	
$XX = \pm .020$	APR BY:		DATE APR:	
$XXX = \pm .010$	APR BY:		DATE APR:	
ANGLES: $= \pm 1^{\circ}$	APR BY:		DATE APR:	
CABINET SQUARENESS: $= \pm .0625$	APR BY:		DATE APR:	

CONFIDENTIAL:
 ALL DESIGN RIGHTS RESERVED
 THE INFORMATION, DATA, DESIGN, AND DRAWINGS EMBODIED IN THIS DOCUMENT AND ALL REPRODUCTIONS THEREOF ARE THE EXCLUSIVE PROPERTY OF DIVERSIFIED WOODCRAFTS, INC.

THESE DOCUMENTS ARE SUPPLIED WITH THE UNDERSTANDING THAT THEY WILL NOT BE DISCLOSED TO THIRD PARTIES WITHOUT WRITTEN CONSENT OF DIVERSIFIED WOODCRAFTS, INC. ANY REPRODUCTION IN PART OR WHOLE WITHOUT WRITTEN CONSENT IS SUBJECT TO LEGAL ACTION.



300 South Krueger Street
 Suring, WI 54174
 diversifiedwoodcrafts.com

TITLE:
 PLANNING DESK
 ASSEMBLY INSTRUCTION

REV.	DESCRIPTION	DATE	NAME	ECN NO.
A	CREATED ASSEMBLY INSTRUCTIONS	10/24/14	EMR	-
REVISION LEVEL				

DRAWING NUMBER:	SCALE:	SHEET:	REVISION:
PT-72P & PT-72M SERIES TABLES	NTS	5 OF 7	REV A

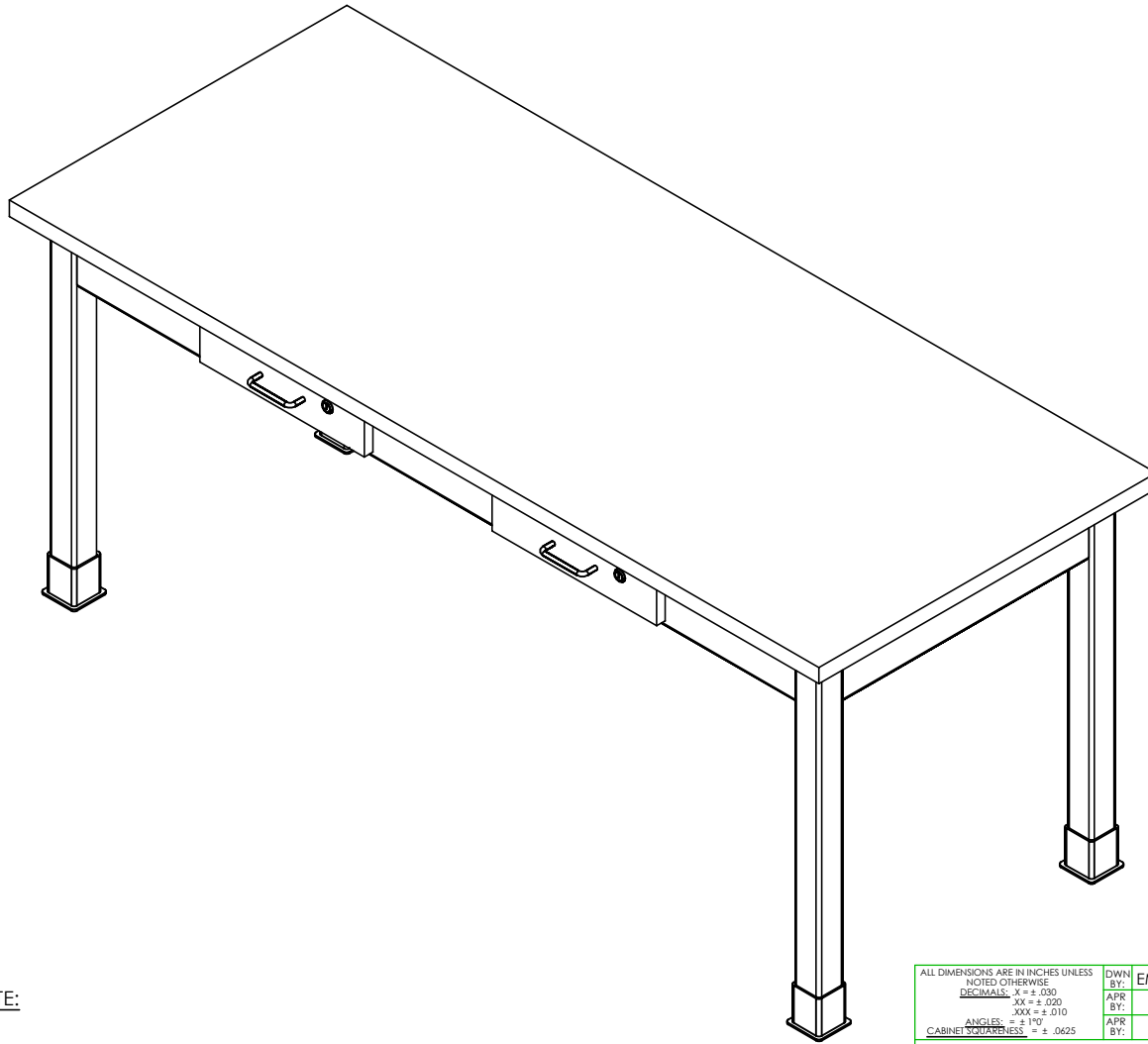

STEP 4:

- TURN TABLE OVER SO TOP IS UP.
- SET YOUR TABLE IN PLACE.
- ADJUST LEG LEVELERS TO LEVEL TABLE.
- SLIDE LEG BOOTS DOWN TO THE FLOOR.
- PLACE DRAWER BOXES IN TABLE.

NOTE:

1.

COMPLETE UNIT SHOWN

ALL DIMENSIONS ARE IN INCHES UNLESS NOTED OTHERWISE	DWN BY:	EMR	DATE DWN:	10/24/14
DECIMALS: .X = ± .030 .XX = ± .020 .XXX = ± .010	APR BY:		DATE APR:	
ANGLES: = ± 1°	APR BY:		DATE APR:	
CABINET SQUARENESS: = ± .0625				

CONFIDENTIAL:
ALL DESIGN RIGHTS RESERVED
THE INFORMATION, DATA, DESIGN, AND DRAWINGS EMBODIED IN THIS DOCUMENT AND ALL REPRODUCTIONS THEREOF ARE THE EXCLUSIVE PROPERTY OF DIVERSIFIED WOODCRAFTS, INC.

THESE DOCUMENTS ARE SUPPLIED WITH THE UNDERSTANDING THAT THEY WILL NOT BE DISCLOSED TO THIRD PARTIES WITHOUT WRITTEN CONSENT OF DIVERSIFIED WOODCRAFTS, INC. ANY REPRODUCTION IN PART OR WHOLE WITHOUT WRITTEN CONSENT IS SUBJECT TO LEGAL ACTION.



300 South Krueger Street
Suring, WI 54174
diversifiedwoodcrafts.com

TITLE:
PLANNING DESK
ASSEMBLY INSTRUCTION

REV.	DESCRIPTION	DATE	NAME	ECN NO.
A	CREATED ASSEMBLY INSTRUCTIONS	10/24/14	EMR	-
REVISION LEVEL				

DRAWING NUMBER:	SCALE:	SHEET:	REVISION:
PT-72P & PT-72M SERIES TABLES	NTS	6 OF 7	REV A

PRODUCT

Butcher Block (Varnished Tops) *Maintenance & Repair*

SPILLS

- Be sure any spills are cleaned up immediately. Excessive moisture and certain chemicals allowed to stand on a finished surface can cause damage.
- Clean spills or soiled areas with a damp cloth and dry thoroughly.
- Periodically, apply a coat of spray wax, paste wax, or lemon oil to finished surface. This will enhance and protect the finish and insure a moisture barrier is intact in the event the finish becomes scratched or worn.

SCRATCHES & DENTS

- Minor scratches and dents can be easily repaired by rubbing the affected area with steel wool or fine grit (#220) sandpaper. Remember, when rubbing or sanding always sand with the grain of the wood. Feather edges of repair in to the surrounding area. Remove all dust and residue and apply a coat of clear lacquer type finish or paint. Clear lacquer type finish can be purchased at most paint or hardware stores. Small cans of touch-up paint are available from your dealer or representative. Paint colors can easily be matched at most paint stores. Confine touch-up only to the area that was sanded. Remember, follow manufacturing directions on product label when refinishing.
- Major scratches and gouges where large portions of wood have been removed or damaged should be handled by a professional experienced in furniture repair with the proper tools and equipment.

MINERAL STREAKS

- Mineral Streaks—Natural Coloring of wood due to mineral deposits in the tree. Repair is not required and will add to the individuality of your table. Sizes can range up to a 1/4" wide and up to 3" in length.

HUMIDITY GUIDELINES

Your Butcher Block was kiln-dried to an initial moisture content of 7.6%. In order to maintain the beauty and integrity of your Butcher Block, it is recommended that special care be taken to keep the relative humidity and temperature within your home or warehouse in the highlighted range. This will limit the amount of expansion and contraction in your natural wood product and minimize the risk of environmental damage.

- **Environment Acclimation:** Environmental damage does not constitute defective product. Allowing your Butcher Block to acclimate to the environment for at least 72 hours prior to installation, following recommended installation practices that allow your Butcher Block to move with the conditions and controlling the environment itself are all key factors that determine the life of your product.
- **Temperature Changes:** It is important to note that as winter temperatures drop, so does relative humidity in the air. The heaters come on which further dries the air. Keeping the area humidified to an acceptable level usually becomes necessary during the winter months. The opposite is true in spring and summer as humidity rises, dehumidifiers and air conditioners become the method of control.

		RELATIVE HUMIDITY %																	
		5	10	15	20	25	30	35	40	45	50	55	60	65	70	75	80	85	90
TEMPERATURE (°F)	30	1.4	2.6	3.7	4.6	5.5	6.3	7.1	7.8	8.7	9.5	10.4	11.3	12.4	13.5	14.9	17	18.5	21
	40	1.4	2.6	3.7	4.6	5.5	6.3	7.1	7.8	8.7	9.5	10.4	11.3	12.4	13.5	14.9	17	18.5	21
	50	1.4	2.6	3.6	4.6	5.5	6.3	7.1	7.9	8.7	9.5	10.3	11.2	12.3	13.4	14.8	16	18.4	20.9
	60	1.3	2.5	3.6	4.6	5.4	6.2	7	7.8	8.6	9.4	10.2	11.1	12.1	13.3	14.6	16	18.2	20.7
	70	1.3	2.5	3.5	4.5	5.4	6.2	6.9	7.7	8.5	9.2	10.1	11	12	13.1	14.4	16	17.9	20.5
	80	1.3	2.4	3.5	4.4	5.3	6.1	6.8	7.6	8.3	9.1	9.9	10.8	11.7	12.9	14.2	16	17.7	20.2
	90	1.2	2.3	3.4	4.3	5.1	5.9	6.7	7.4	8.1	8.9	9.7	10.5	11.85	12.6	13.9	15	17.3	19.8
100	1.2	2.3	3.3	4.2	5	5.8	6.5	7.2	7.9	8.7	9.5	10.3	11.2	12.3	13.6	15	17	19.5	

Example: If conditions in a warehouse are 60% relative humidity at 50 degrees Fahrenheit Dry wood will pick up moisture until 11.2% is reached, regardless of wood species and initial moisture content.