

MB4836LB MOBILE MAGNETIC COMBINATION GHOST GRID/WHITEBOARD

Product Specifications

| | |
|----------------------------|--------------------------------------|
| Item Number | MB4836LB |
| Material | Painted Steel |
| Frame | Aluminum; 1" edging |
| Surface Material | Magnetic Painted Steel |
| Grid Pattern | 2" x 2" (side one) / None (side two) |
| Whiteboard Tape | Ships with 2 rolls |
| Full Dimensions | 51.5"W x 20.5"D x 65.5"H |
| Board Dimensions | 48"W x 36"H |
| Base Dimensions | 51.5"W x 20.5"D |
| Tray Style | Full Length |
| Casters (4) | 2" casters; two with locking brakes |
| Actual Weight | 31 lbs. |
| Shipping Method | Freight |
| Shipping Carton Dimensions | 54"W x 45"D x 2"H |
| Shipping Weight | 41 lbs. |
| Assembly Required | Yes |

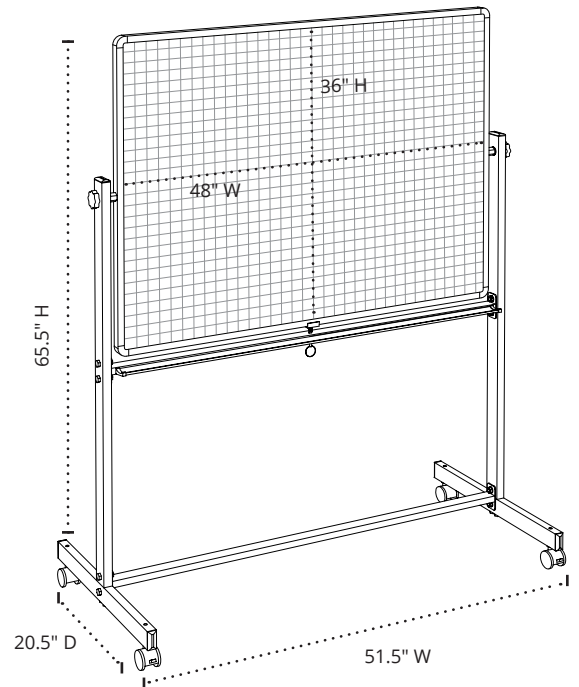
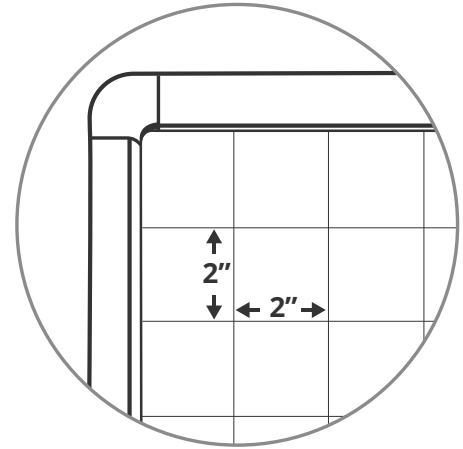

To Order, Call Your
Sales Representative
or 800-323-4656