



# TETON

Natural Reliability™

## XUV SERIES

### XUV Professional UV Clarifier

## INSTRUCTION MANUAL

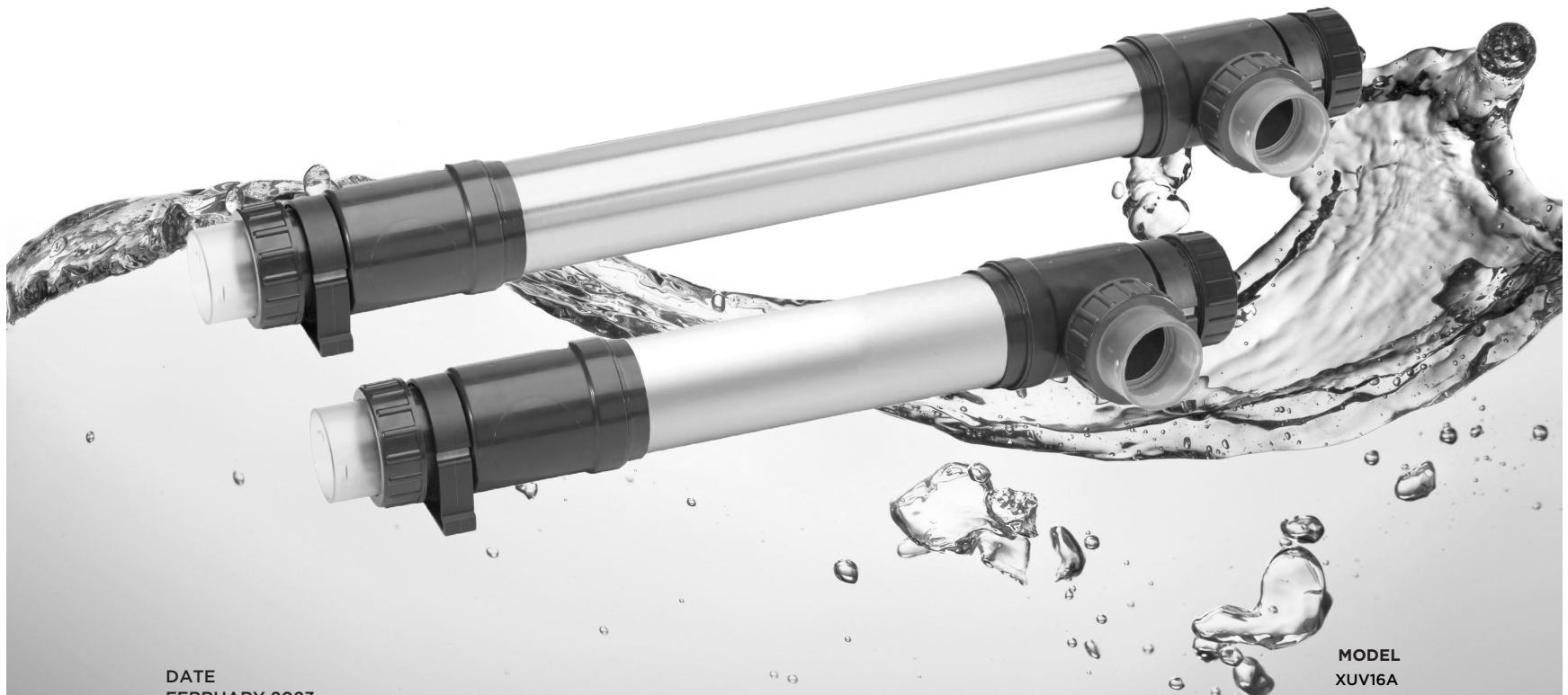

DATE  
FEBRUARY 2023

Teton Dynamics  
P.O. Box 3031  
San Leandro, CA 94578-0031

MODEL  
XUV16A  
XUV40S  
XUV80S  
XUV120S

# XUV PROFESSIONAL CLARIFIER

## XUV16A/XUV40S/XUV80S/XUV120S

[www.tetonus.com](http://www.tetonus.com)  
**800.752.0399**  
[info@tetonus.com](mailto:info@tetonus.com)

**WELCOME TO THE WORLD OF TETON,  
NATURAL RELIABILITY™!**

You Made The Right Choice Investing In  
This Quality Product. Thank You And Enjoy.

**BEFORE USING THIS PRODUCT, PLEASE READ  
THESE INSTRUCTIONS CAREFULLY AND  
FAMILIARIZE YOURSELF WITH THE UNIT.  
PLEASE KEEP THESE INSTRUCTIONS IN A SAFE  
PLACE FOR FUTURE REFERENCE.**

### TECHNICAL SPECIFICATIONS

MODEL NO.	XUV16A	XUV40S	XUV80S	XUV120S
<b>WATTAGE</b>	16W	40W	80W	120W
<b>MAX. PRESSURE</b>	36 psi 2.5 bar	36 psi 2.5 bar	36 psi 2.5 bar	36 psi 2.5 bar
<b>MAX. FLOW RATE</b>	2,250 GPH 8,500 L/H	3,750 GPH 14,200 L/H	5,000 GPH 18,900 L/H	7,000 GPH 26,500 L/H
<b>MAX. POND SIZE</b>	4,500 GAL 17,000 L	7,500 GAL 28,350 L	10,000 GAL 37,850 L	14,000 GAL 53,000 L
<b>INLET/OUTLET SIZE</b>	2"	2"	2"	2"
<b>CORD LENGTH</b>	5.5 FT 1.7m	5.5 FT 1.7m	5.5 FT 1.7m	5.5 FT 1.7m

## IMPORTANT SAFEGUARDS



Please read the operating instructions and familiarize yourself with the equipment before placing it in service. Correct and safe use of the system requires strict compliance with these safety instructions. For safety reasons, persons less than 16 years of age or persons that are not familiar with these instructions, should not use this equipment.

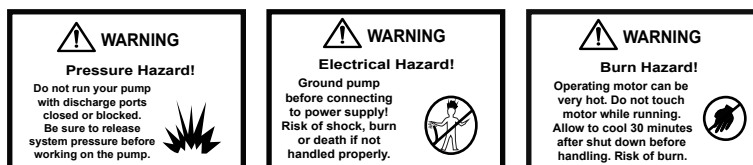

- See the Technical Specifications for the required voltage and current.
- The UV unit may only be connected to an electrical installation that meets the legal requirements. A GFCI (30ma) and grounded sockets are required. If in doubt always use a certified electrician to install.
- The UV unit, ballast, plug and power cord must be positioned at least 2m from the pond or fish tank.
- Always keep the plug free from moisture. Ensure that water cannot track down the power cord to the socket. (See Page 4, Figure 1 for how to loop the power cord).
- Never submerge the UV unit in liquid.
- The UV unit can withstand a maximum pressure of 36 psi / 2.5 bar.
- The UV unit is only suitable for fresh, not salt, water.
- The UV unit is designed to operate with a water temperature between 33 and 104 degrees F / 0 and 40 degrees C. Outside these temperatures the UV unit must be completely disconnected from the water.
- Before use, check the whole UV unit, power cord and plug for damage. In case of any damage, the UV unit must not be used. Please let your dealer assess any damage.
- The UV unit may only be connected if there is a sufficient flow of water.
- To avoid possible harm to eyes or skin, the operation of the UV-C lamp should only be checked through the transparent fittings of the UV unit.
- During maintenance, the UV unit and pump must be disconnected from the electrical outlet. Be aware that the UV unit and the lamp can remain hot for up to 10 minutes after being disconnected.

## PRODUCT DESCRIPTION

The XUV Professional UV Clarifier ensures crystal-clear water. The sophisticated design and high quality materials produce high UV-C radiation with a wavelength of precisely 253.7m. This precise level of UV energy treats optimizes the units performance to provide clear and healthy water for your aquatic pets.

Due to the large diameter metal housing, the water stays in contact with the UV-C radiation for an extra-long time. This large housing also ensures that there is minimal pressure loss during the water treatment. The housing is polished on the inside to minimize the chance of any dirt sticking to the walls. Overall, this increases the effectiveness of the UV-C radiation 35%.

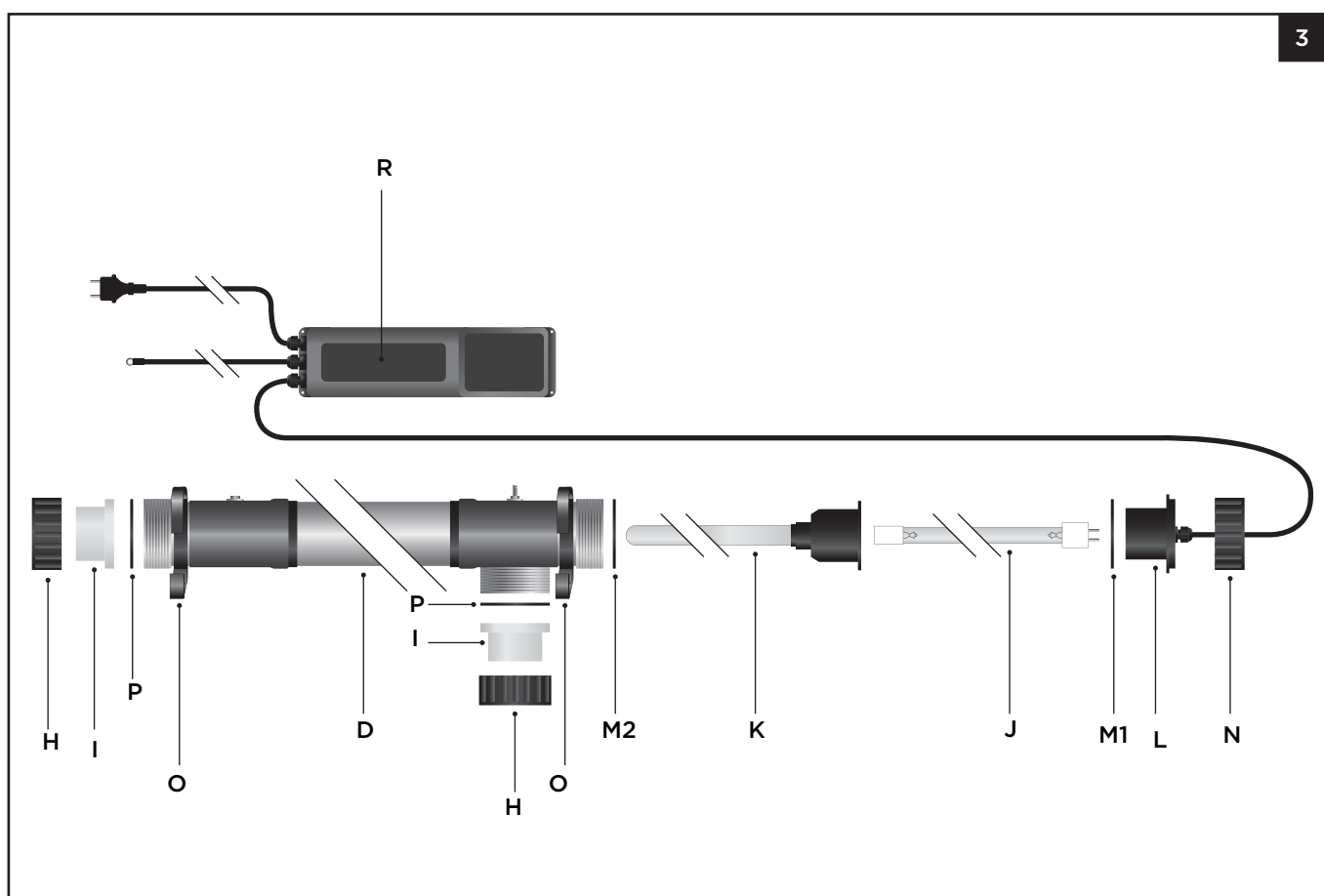
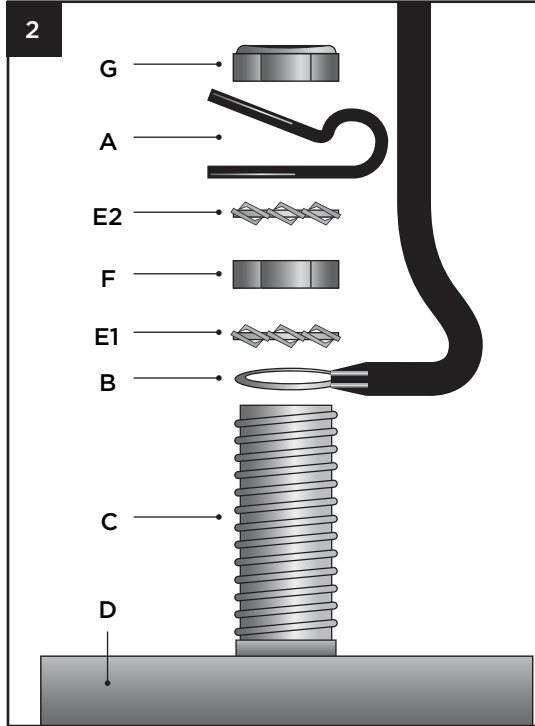
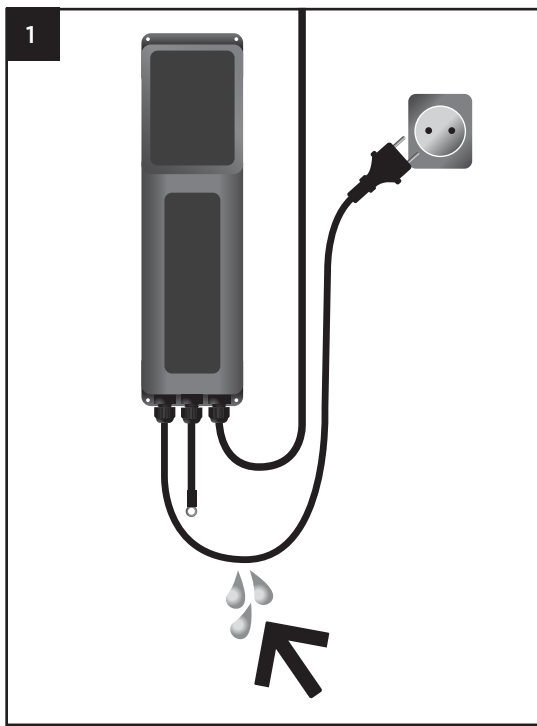

## **ASSEMBLY (SEE PAGE 4, FIGURE 2)**

1. Place the strain relief clip (A) about 10-12cm from the eye of the earth cable (B).
2. Slide the eye of the earth cable (B) over the earth pin (C) that is fastened to the housing (D).
3. Slide the first spring washer (E1) over the earth pin (C).
4. Place the hexagonal nut (F) on the earth pin and tighten it.
5. Slide the second spring washer (E2) over the earth pin (C).
6. Slide the strain relief clip (A) over the earth pin (C).
7. Place the last lock nut (G) on the earth pin (C) and tighten it carefully with a spanner in Step 8.
8. Ensure that the sequence follows precisely that shown on Page 4, Figure 3.

## **INSTALLATION**

The UV unit must be placed in a dry, well-ventilated area, out of direct sunlight. The best position, if possible, is after the filter. The installation must always be carried out vertically. Take into account accessibility for maintenance (see also Maintenance).

1. Undo the lock nut (H) from the housing (D) and keep this for the connecting link (I) used in Step 7.
2. Carefully unpack the UV-C lamp (J) and slide this into the quartz sleeve (K).
3. Put the UV-C lamp (J) into the lamp holder (L) and slide this further into the quartz sleeve (K). Make sure that the O-rings (M1&M2) sitting properly.
4. Tighten the nut (N) hand-tight in the housing (D).
5. Mount the pipe clamps (O) in the required place. The UV unit will hang from these. Take into account the length of the cables (see Step 6).
6. Mount the electronics box (R) in the required place. Take into account the length of the cables.
7. With the lock nut (H), fasten the connecting link (I) to the housing (D), making sure that the O-rings (M1&M2) are seated properly.
8. Place the apparatus in the pipe clamps (O) and glue the connecting link (I) between the pipes.
9. Ensure that enough water flows through the UV unit and plug the UV unit into the appropriate socket. You can see if the UV-C lamp is on by looking through the transparent connecting link (I). Check the whole assembly for possible leaks.
10. The UV unit can be turned off by simply pulling the plug out of the socket.

## **MAINTENANCE**

The UV unit needs maintenance at least once per half year. During maintenance, the UV unit must be disconnected from the electrical outlet. Chalk deposits and possibly algae must be removed from the quartz sleeve (K) and the housing (D). The UV-C lamp (J) only has to be changed after 9,000 hours of use. The actual lifetime is dependent on the number of times it is turned on and off.

1. Unplug the UV unit from the electrical outlet and close the pipes.
2. Ensure that the water is drained out of the UV unit.
3. Loosen the bolt (N) and disconnect the UV-C lamp (J) from the lamp holder (L). If necessary, you can also replace the lamp.
4. Carefully raise the quartz sleeve (K).
5. The quartz sleeve (K) can be cleaned with an appropriate cleaner. After cleaning, rinse the quartz sleeve (K) thoroughly. Use a soft cloth to avoid scratches!
6. The housing (D) can now also be cleaned. This can be done with a brush; do not use any chemicals.
7. After cleaning, place the quartz sleeve (K) back in the housing (D). Ensure that the O-ring (M1&M2) is seated properly and that the quartz sleeve (K) slides into the holder.
8. Put the UV-C lamp (J) into the lamp fitting (L) and slide both into the quartz sleeve (K).
9. Tighten the nut (N) on the housing (D) hand-tight. (See Installation Step 9).

Note: To change the housing and/or the electronics box, the earth must be completely disconnected. The component parts must be saved because they do not come with a new housing or electronics as standard.

## AVAILABLE REPLACEMENT PARTS - XUV16A/XUV40S/XUV80S/XUV120S

PART NO.	FIGURE NO.	DESCRIPTION
910016	J	16W Replacement Lamp
910040	J	40W Replacement Lamp
910080	J	80W Replacement Lamp
910120	J	120W Replacement Lamp
911016	L, M1, N, R	Replacement Transformer Assembly, 16W
911040	L, M1, N, R	Replacement Transformer Assembly, 40W
911080	L, M1, N, R	Replacement Transformer Assembly, 80W
911120	L, M1, N, R	Replacement Transformer Assembly, 120W
910001	I, H, P	Replacement 2" Union Set with O-ring
910002	K, M1, M2	Replacement Quartz Sleeve with O-rings, 16W
910003	K, M1, M2	Replacement Quartz Sleeve with O-rings, 40/80W
910004	K, M1, M2	Replacement Quartz Sleeve with O-rings, 120W
910010	D	Replacement Aluminum Housing for 16W UV
910011	D	Replacement Stainless 304 Housing for 40/80W UV
910012	D	Replacement Stainless 304 Housing for 120W UV

## LIMITED PRODUCT WARRANTY

- CMT Group LLC, a California limited liability company d/b/a Teton™ (the “Company”) expressly warrants to the original purchaser that, for a period of two (2) years from the date of sale, the covered product (the “Product”) will be reasonably free of defects in materials and workmanship and that when properly handled, will conform, within accepted tolerance to applicable manufacturing specifications. This Limited Product Warranty (“Limited Warranty”) only applies to Company’s Products that are used, stored, handled, and installed in the manner recommended by the Company in the Product instruction manual.
- Notwithstanding this Limited Warranty, customer acknowledges that some parts of the Product are consumable and may need to be replaced as part of ongoing Product maintenance, as recommended in the Product instruction manual, and are therefore not covered by this Limited Warranty.
- Company will, at its option, repair or replace Product without charge, if the Product fails or does not perform as warranted solely due to a manufacturing defect within the warranty period, subject to the exclusions set forth in this Limited Warranty.
- Repair or replacement during this two (2) year warranty shall not include: reasonable labor charges necessary to repair or replace the defective Product, shipping costs, and packing and insurance costs. During the entire two (2) year warranty, Company’s obligation as to repair or replacement shall further be limited to repair or replacement with the models of the Product that are available at the time of the repair or replacement, and shall be limited to the repair or replacement of only the specific Product that fails due to a manufacturing defect. Any repaired or replaced Product shall also remain subject to the original two (2) year warranty from the date of the original sale, and any repair or replacement shall not extend the original warranty period in any manner or start a new warranty period.
- You may obtain coverage under this Limited Warranty by providing Company with proof of original purchase. For service under this Limited Warranty, you must first contact the seller, distributor, retailer, or dealer from whom you purchased the Product and provide the following: copy of original receipt, your name and address, a description of the Product (including the serial number/date code set forth on the Product), and the nature of the defect. To expedite any warranty claims and processing, please submit to us the product registration card included with your purchased Product promptly after your purchase.
- All warranty repairs must be performed by the Company, or a Company authorized third-party. Any repairs performed by you or an unauthorized third-party will not be compensated by Company and are not the responsibility of the Company and will void this warranty.
- **DISCLAIMER OF WARRANTIES:** Company’s Products must be stored, handled, installed, used, and maintained in accordance with instructions provided by Company, and this Limited Warranty is conditioned upon compliance with all such instructions. Copies of the Company’s use guide/care guide are included with the Product and available from the Company at the address listed below. You may also obtain these materials by contacting Company at (800) 752-0399 or on the Company’s website [www.tetonus.com](http://www.tetonus.com).
- This Limited Warranty does not cover defects caused by:
  - non-compliance with Company’s use guides, care guides, and/or instruction manual. Such failures include, but are not limited to, exposure to physical abuse, including, but not limited to chemical abuse (e.g. harsh cleansers and solvents), thermal abuse or shock (e.g. excessive heat or cold), incompatibility of fluid used near the Product, or misuse;
  - improper storage, installation, handling, and/or use of the Product;
  - damage not resulting from manufacturing defects that occur while the Product is in the customer’s possession;
  - unreasonable or unintended use of Product;
  - products installed with known or visible manufacturing defects at the time of installation;
  - minor conditions such as stains, scratches, etc.
- Any information or suggestion by Company with respect to the Products concerning applications, specifications, or compliance with codes and standards is provided solely for your convenient reference and are made without any representation as to accuracy or suitability. You must verify and test the suitability of any information with respect to the Products for your specific application.
- **THE WARRANTIES SET FORTH IN THIS LIMITED WARRANTY ARE THE ONLY WARRANTIES MADE BY COMPANY IN CONNECTION WITH THE PRODUCT. COMPANY CAN NOT AND DOES NOT MAKE ANY IMPLIED OR EXPRESS WARRANTIES WITH RESPECT TO THE PRODUCT, AND DISCLAIMS ALL OTHER WARRANTIES, INCLUDING, BUT NOT LIMITED TO, ANY WARRANTY OF MERCHANTABILITY OR FITNESS FOR A PARTICULAR PURPOSE. PRODUCTS SOLD BY COMPANY ARE SOLD ONLY TO THE SPECIFICATIONS SPECIFICALLY SET FORTH BY COMPANY IN WRITING. OTHER THAN THE LIMITED WARRANTY SET FORTH HEREIN, COMPANY MAKES NO OTHER WARRANTIES, EXPRESS OR IMPLIED. COMPANY’S SOLE OBLIGATION UNDER THIS WARRANTY SHALL BE REPAIR OR REPLACEMENT OF NON-CONFORMING PRODUCTS. BUYER ASSUMES ALL RISK WHATSOEVER AS TO THE RESULT OF THE USE OF THE PRODUCTS PURCHASED, WHETHER USED SINGULARLY OR IN COMBINATION WITH ANY OTHER PRODUCTS OR SUBSTANCES.**
- **LIMITATION OF LIABILITY:** No claim by the buyer/owner of any kind, including claims for indemnification, shall be greater in amount than the purchase price of the Product in respect to which damages are claimed. IN NO EVENT SHALL COMPANY BE LIABLE TO BUYER/OWNER IN TORT, CONTRACT OR OTHERWISE, FOR ANY SPECIAL, INDIRECT, INCIDENTAL, CONSEQUENTIAL, RELIANCE, STATUTORY, SPECIAL, PUNITIVE OR EXEMPLARY DAMAGES, INCLUDING, BUT NOT LIMITED TO, LOST PROFITS, LOSS OF USE, LOSS OF TIME, LOSS OF REVENUES, INCONVENIENCE, LOSS BUSINESS OPPORTUNITIES, DAMAGE TO GOOD WILL OR REPUTATION, OR LOSS OF DATA, EVEN IF ADVISED OF THE POSSIBILITY OF SUCH DAMAGES OR SUCH DAMAGES COULD HAVE BEEN REASONABLY FORESEEN, IN CONNECTION WITH, ARISING OUT OF, OR AS A RESULT OF, THE SALE, DELIVERY, SERVICING, USE OR LOSS OF USE OF THE PRODUCT SOLD HEREUNDER, OR FOR ANY LIABILITY OF BUYER TO ANY THIRD PARTY WITH RESPECT THERETO.
- All provisions of this Limited Warranty are severable and if any provision shall be deemed invalid, the remaining provisions shall remain in full force and effect.
- Please consult your retailer for quality original Company replacement parts.
- Visit [www.tetonus.com](http://www.tetonus.com) for your nearest dealer.
- Contact Information:
  - Any question concerning this warranty should be addressed to:  
Teton  
P.O. Box, 1044  
San Leandro, CA 94577  
Phone: 800-752-0399  
Email: [info@tetonus.com](mailto:info@tetonus.com)  
Website address: [www.tetonus.com](http://www.tetonus.com)