

G7 ELLIPTIC ROTOR PUMP

400 x 300 Ø ideal for the transfer of large quantities of product.

The pump has a patented system which eliminates the weight and pressure of the valve discharge column.

Reclinable Stainless Steel conveying hopper for reduced height.

Auger 300 - 400 Ø.

Stainless Steel load-bearing frame on vibration-damping pads, transportable with transpallets.

Centralised lubrication system.

Safety devices.

45° horizontally or vertically slanted discharge outlet, with ball or Garo/la fitting.

On request:

- Hoppers in various sizes.
- Inverter.
- Compression tank.



Safety Device (on hopper)



Automatic Lubricator



Bolt Auger Safety





Technical Data

	G7
Hourly production (Grapes)	35-50 ton/H
Electric motor power	11
Unloading height (Grapes)	8-12m
Unloading distance (Grapes)	40-60m
Stainless steel rotor	Ø 400x300
Hopper auger	Ø 300-400mm
Pump rotation speed	47/69 giri min. r.p.m.
Pump discharge outlet	Ø 100/120
Weight	450kg

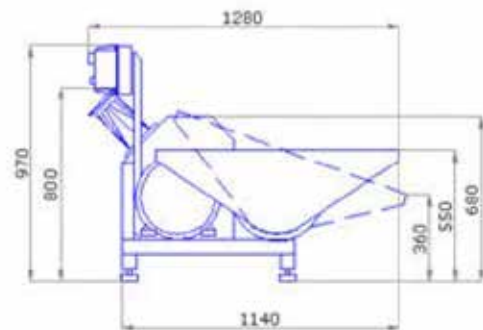
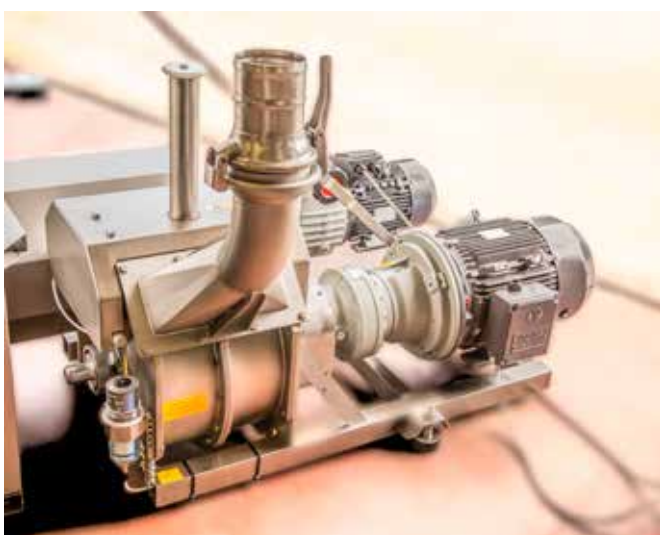

Strazzeri