

POOLEX

POOLEX Turbo Salt

Swimming Pool Salt Chlorinator

TECHNICAL SUPPORT
www.poolex.fr



2-EN

USER GUIDE

ACKNOWLEDGEMENTS

Dear client,

Thank you for your purchase and your trust in our products.

Our products are the result of years of research in the design and manufacture of heat pumps, treatment and filtration systems for pools. Our goal is to deliver high-quality products with exceptional performance.

We took great care to put together this manual so you can get the most out of your Poolex Salt Chlorinator.

! PLEASE READ CAREFULLY !

These installation instructions form an integral part of the product.

They must be given to the installer and kept by the user.

If you lose this manual, please visit our website:

www.poolex.fr

The warnings and guidelines contained in this manual must be carefully read and understood as they provide important information concerning the safe handling and operation of the chlorinator. We recommend that you keep this manual handy for future reference.

Installation must be performed by a qualified professional in accordance with regulations in force and the manufacturer's instructions. Errors made during installation can cause physical injuries to people and animals as well as mechanical damage for which the manufacturer shall not be held liable.

After unpacking the chlorinator, please check the contents for any damage.

Before plugging in the chlorinator, ensure that the instructions provided in this manual are compatible with actual installation conditions and do not exceed the maximum authorised limits for the product in question.

In the event of a defect and/or malfunction, electrical power must be switched off and no attempts to repair the fault should be made. Repairs must be carried out by an authorised technician using original spare parts. Non-compliance with the aforementioned clauses can negatively impact the safe operation of the chlorinator.

In order to guarantee the efficiency and proper functioning of the chlorinator, it must be regularly maintained in accordance with the instructions provided.

In the event the chlorinator is sold or transferred to another party, please ensure that all technical documentation is given to the new owner together with the equipment.

This chlorinator is designed exclusively to treat swimming pools. Any other use is considered inappropriate, incorrect and potentially dangerous.

TABLE OF CONTENTS

All contractual and extra-contractual liability on the part of the manufacturer / distributor shall be considered null and void in the event of damage caused by errors in the installation or operation, or due to non-compliance with the instructions provided in this manual and standards in force for the installation of equipment discussed in this document.

SUMMARY:

ACKNOWLEDGEMENTS	01
SAFETY INSTRUCTIONS	04
HOW IT WORKS	05
OPERATING LIMITS	05
FEATURES	07
INSTALLATION	08
BEFORE USE	11
Adding salt	11
Required salt levels	11
Quick reference table for adding salt	12
USE	14
Overview of control panel	14
Selecting operating modes	15
TROUBLESHOOTING	17
Error codes and fixes	19
Cleaning the cell	20
Replacing the cell	21
WINTERIZING	22
Active winterizing	22
Passive winterizing	22
Restarting in spring	22
USEFUL TIPS	23
General principles	23
List of Recommended Actions	23
List of Prohibited Actions	23
SUPPLEMENTARY ELECTRICAL BONDING (POOL EARTHING)	24
WARRANTY.....	25

SAFETY INSTRUCTIONS

GENERAL TERMS AND CONDITIONS OF DELIVERY

All products and packaging, even those delivered carriage paid, travel at the risk of the recipient.

Persons responsible for accepting delivery of the device must perform a visual inspection to note any damage that may have occurred during transportation. Any damage during transportation must be noted by the recipient on the delivery receipt of the transporter and confirmed by registered post sent to the transporter within 48 hours.

SAFETY INSTRUCTIONS

Installation and maintenance of any upstream electrical components must be performed by a qualified electrician. Failing to do so may result in electric shock, serious injury, property damage and even death.

Prior to any maintenance or operation, ensure that the salt chlorinator and any other devices are shut down and the main power supply is off.

The salt chlorinator's external power adaptor must be connected to a main power supply separate from the filtration system (no feedback control), equipped with a 30mA residual current device and an earthing system.

The salt chlorinator must be plugged into an outlet located in a well-ventilated area to prevent overheating. Do not plug the salt chlorinator into an outlet where it could be damaged by humidity or rain.

The person responsible for installing the chlorinator must carefully read this manual. In the event of a malfunction or erroneous operation, please contact the nearest authorised reseller or technical support.

If a part is damaged, ensure a replacement is purchased from the manufacturer or an authorised reseller.

NOT COMPLYING WITH THESE WARNINGS CAN RESULT IN PROPERTY DAMAGE, ELECTRIC SHOCK, COMPLICATIONS OR OTHER SERIOUS INJURIES AND EVEN DEATH.

WARNING - To avoid the risk of injury, do not allow children to operate this device.

WARNING - Intensive use of the pool (or spa) or high temperatures may require an increased level of chlorine production in order to maintain adequate levels of free chlorine.

HOW IT WORKS

Salt chlorination of a pool works by using salt electrolysis to disinfect the water; this electrochemical process converts the salt present in the water into a disinfectant (hypochlorite ions).

Once this process is complete, hypochlorite turns back into salt after coming into contact with organic material (bacteria, cells) or under the effect of UV rays or other sources of light, starting the cycle over again.

In order to maintain a good level of disinfectant in the water, the following guidelines must be respected:

- A proper concentration of salt in the water: 3 g/l
- Adequate filtration time (as a reminder, a good estimate is: Filtration Time = T° water / 2)
- A good water balance with a pH between 7.0 and 7.8 (for more information see Taylor watergram)
- Regular cleaning of your pool to remove any plant debris
- In case of frequent use, consider using the boost function.

WARNING - Salt water chlorination alone will not clear up green water by itself. In the event of algae appearing (e.g. after a period of high temperatures or frequent use), it may be necessary to supplement with chlorine tablets. Do not put the chlorine tablets directly into the skimmer; use a floating dispenser.

OPERATING LIMITS

As with any pool, it's important that the filtration time is long enough to maintain a good chemical balance in the pool water, including pH, alkalinity and calcium levels.

The only special requirement to use a salt chlorinator is maintaining proper levels of salt and stabiliser.

To get the most out of your pool, it is important to maintain these levels in order to avoid corrosion and scale deposits. We therefore recommended that you test all of the basic parameters of the water at least once per week.

In addition, we recommended getting your pool water tested by a professional at least twice per season.

Your local pool store can provide you with the chemicals and steps to take to adjust the chemical properties of the water.

Don't forget to let the store know that you use a salt chlorinator.

Check your values and correct them at least once a week:

Parameter	Target values	Comments
Salinity	3 to 4 g/l	Once the salt is dissolved in the water (+/- 24 to 48h), salt concentration will only vary slightly over the course of the season.
pH level	7.2 to 7.4	Please note, a pH above 7.8 suppresses the disinfecting properties of hypochlorite.
Free chlorine concentration	From 0.5 to 3.0 ppm	Measurements must be taken from around the return inlets when the chlorinator is switched on, preferably in the morning and out of direct sunlight.
! important! Stabilizer rate (Cyanuric Acid)	From 20 to 50ppm	Hypochlorite is a relatively unstable disinfectant. With too low a level of stabilizer, the hypochlorite will turn back into salt too quickly without having had enough time to disinfect. Conversely, with too high a level of stabilizer, the hypochlorite will be blocked. Be careful, if the level of stabilizer is much too high, the pool will have to be partially drained to add water without stabilizer.
Additional tests		
Total alkalinity (TA)	From 80 to 150 ppm	This level measures the concentration of mineral salts (carbonates, bicarbonates, hydroxides) in the water. It stabilizes / buffers the water balance. High TA levels interfere with the effects of pH regulation and scale deposits may begin to appear.
Water hardness	From 150 to 300 ppm	Water hardness represents the amount of calcium carbonate present in your water.

In addition, temperature plays a major role in the correct usage of your chlorinator: Water temperatures lower than 10°C will render the system inoperative (E2 warning will be displayed)

Water temperatures higher than 32°C will reduce the effectiveness of hypochlorite. The addition of chlorine tablets is therefore recommended for consistently high temperatures; do not place chlorine tablets directly into the skimmer, use a floating dispenser.

WARNING - the presence of iron in your water (ferruginous water) may lead to rust deposits in your pool and require the use of a metal sequestrant - please consult a professional.

FEATURES

The salt chlorinator contains the latest electronic monitoring technology for ease of use. You can easily adjust the production of disinfectant to suit your needs, maximizing efficiency while remaining environmentally friendly. In addition to these easy-to-use settings, it also has a selfcleaning function for the cell and a self-test mode in the event of a warning or error code.

For example, the chlorinator displays a warning when it detects low salinity levels, improper temperatures or a lack of water flow (see section on errors codes and fixes).

The compact size of the chlorinator and its integrated control panel allows for easy installation and a smaller footprint. The water inlet and outlet are on the same axis, reducing the need to rearrange piping.

Poollex Turbo Salt						
Model	100	200	300	400	600	800
Maximum volume treated (m ³)	10	20	30	40	60	80
Salt concentration (g/l)	3 to 4					
Input voltage (VAC)	230Vac/50Hz					
Output voltage (VDC)	12	24	24	24	24	24
Output current (A)	1,0	2,0	2,0	2,0	2,0	2,5
Hypochlorite production (g/h)	2	4	6	8	12	18
Min. flow rate in cell	2 (m ³ /h)					
Max. flow rate in cell (m ³ /h)	10 (m ³ /h) - above this level a bypass is required					
Connectors supplied (2 types)	1,5" D50 mm et D32/38mm					
Temperature sensor	YES					
Flow sensor	YES					
Cell cleaning	YES though reverse polarity					
Covered mode	YES (manual)					
BOOST mode	YES (2 BOOST levels)					

Dimensions (in mm)

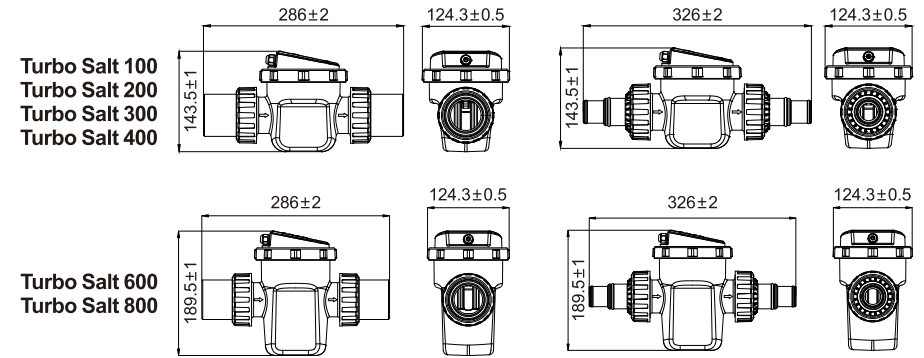

INSTALLATION

Prior to installation, please verify the following:

Ensure the electricity and water circulation system are switched off, and close the valves on the pipes connected to the chlorinator.

Ensure any pipes used (not supplied) are compatible with the chlorinator.

Dimensions of the 2 types of connectors supplied:

- OPTION 1: 1.5" (metric: Ø50 mm) connectors to be sealed using PVC cement
- OPTION 2: D32 or 38 mm push fit connectors

Remove any obstructions

Lubricate the fittings

Ensure the direction of water flow corresponds to the direction indicated on the chlorinator: " ← ".

The salt chlorinator must be installed on the return line carrying water from the pool filter back to the return inlets, as shown in Figure 1 (horizontal assembly) and Figure 2 (vertical assembly).

If using with a water heating system, install the chlorinator downstream from the latter. The chlorinator must be the final element of the circuit.

Installation without a bypass is possible if your pump has a flow rate of < 10m³/h, however, using a bypass is strongly recommended to allow the hydraulic circuit to be isolated. If the flow rate of your pump is > 10m³, a bypass is required.

INSTALLATION

CASE 1 : Using D50mm PVC pipes:

If you need to cut existing D50mm PVC pipe, the length of the cut must be 230 mm. Make sure to use special PVC cement for 1.5" (D50) connectors.

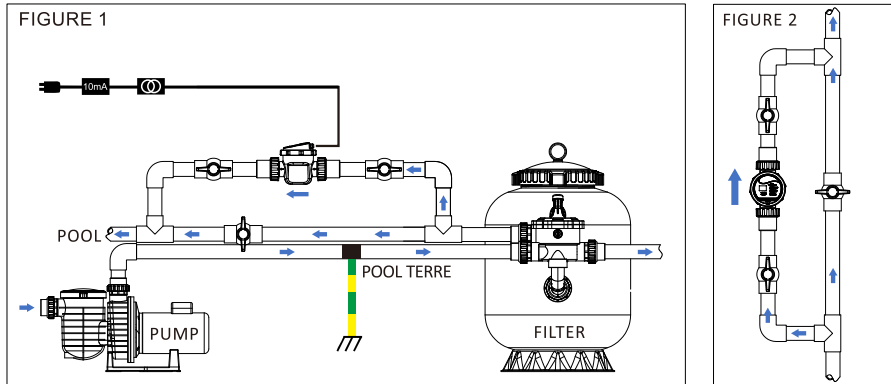

If you want to insert the chlorinator into an existing pipe (or fit on to a pipe), you must cut out a section measuring 230mm in length.

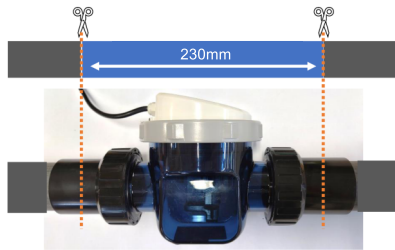

CASE 2 : Using D38mm or D32 pipe:

When using this type of pipe, another length of pipe, minimum 50cm (not supplied), equivalent to the one in place must be added to the outlet of the filter; consider adding a valve (if not already present) just after the chlorinator to be able to isolate this section and facilitate maintenance.

INSTALLATION

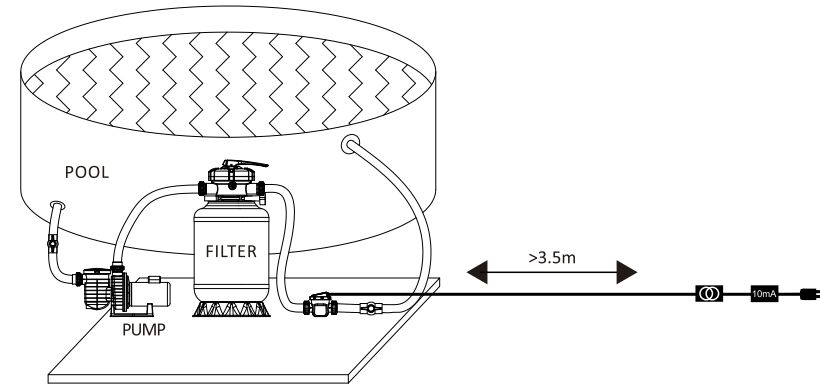

The power supply of the salt chlorinator must be connected to a separate power source equipped with a 30mA residual current device, sheltered from the rain and at least 3.5 m away from the pool. In the event of tripping the residual current device, check system integrity before resetting. In case of doubt, contact a professional.

The salt chlorinator must be plugged into an outlet located in a well-ventilated area to prevent overheating.

Do not install in places where water can easily ingress to prevent damage to the electrical components caused by humidity or rain. For this purpose, a floor or wall mounting bracket is supplied (ref.: CL-TSLFIX)

Mounting bracket ref. CL-TSLFIX

Using the wall or floor mounting bracket

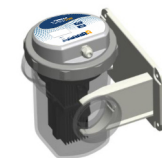

BEFORE USE

Adding salt



IMPORTANT: Before adding salt, ALWAYS perform a test to measure the pre-existing salt levels (test strips or electronic tester).

Only use salt which complies with European standard EN 16401 to extend service life and improve efficiency of the chlorinator cell.



DO NOT ADD chemical products or salt directly into the skimmer. This can damage the cell. If the chlorinator cell has already been installed, do not switch on before adding salt and ensure salt is completely dissolved.

When adding salt, it's preferable to pour the salt into the deepest part of the pool and then switch on the filter pump to circulate the water and dissolve the salt (the cell must remain switched off during this time).

In summer, salt may take 24 - 48 hours to dissolve, and even longer in winter.

Do not place the plastic bag of salt into the water as the chemicals and inks on the bag can interfere with water balance. Make an opening in the bag, then empty its contents. Once the bag is empty, dispose in an appropriate receptacle or recycle if possible.

Required salt levels

The system can operate in a wide range of salinities, from a minimum of 2,700 ppm (parts per million) up to 4,500 ppm. However, optimal salt concentration is around 3,000 ppm. To achieve this salinity level, add around 3 kg of salt per 1 m³ of water (or 25 pounds of salt per 1,000 gallons of water).

TIP: When adding large quantities of salt, always start by testing the salinity of the water and gradually adding salt, testing the concentration each time.

If you're unsure of the volume of your pool (m³), you can calculate it using the following equations:

Rectangular pool: Length x Width x Average Depth

Round pool: Diameter x Diameter x Average Depth x 0.80

Oval pool: Length x Width x Average Depth x 0.90

Before adding salt, test your water to measure salt concentration, then add the corresponding quantities according the table below (next page).

If not enough salt is added, efficiency is reduced and the level of chlorine production will be too low.

BEFORE USE

In addition, operating at low salinity levels will reduce the longevity of the cell. The salt in your pool is constantly recycled, limiting the amount of salt lost during a bathing session. Losses are mainly due to the addition of extra water replacing water lost as a result of splashes, run-off, filter cleaning and drainage.

Salt is not lost through evaporation.



IMPORTANT:

In the event of excess salinity (> 4.5 g/l), partial emptying of the pool may be necessary in order to add fresh water.

Quick reference table for adding salt

Salt Addition Calculation Chart

Salinity before adding salt (PPM) (1ppm=1kg/m³)

Volume in m ³	0	500	1000	1500	2000	2500	3000	3500
Amount of salt required (kg)								
15	53	45	38	30	23	15	8	0
23	79	68	57	45	34	23	11	0
30	106	91	76	60	45	30	15	0
38	132	113	95	76	57	38	19	0
45	159	136	113	91	68	45	23	0
53	185	159	132	106	79	53	26	0
61	212	181	151	121	91	60	30	0
68	238	204	170	136	102	68	34	0
76	265	227	189	151	113	76	38	0
83	291	249	208	166	125	83	42	0
91	318	272	227	181	136	91	45	0
98	344	295	246	197	147	98	49	0
106	371	318	265	212	159	106	53	0
114	397	341	284	227	170	113	57	0

121	424	363	302	242	181	121	60	0
129	450	386	322	257	193	129	64	0
136	477	409	341	272	204	136	68	0
144	503	431	346	288	215	144	72	0
151	530	454	378	302	227	151	76	0
159	556	477	397	318	238	159	79	0
167	582	499	416	333	249	166	83	0
174	609	522	435	348	261	174	87	0
182	635	545	454	363	272	181	91	0
189	662	567	473	378	284	189	95	0

x1000 gal

Amount of salt required (pounds)

4	117	100	83	67	50	33	17	0
6	175	150	125	100	75	50	25	0
8	234	200	167	133	100	67	33	0
10	292	250	209	167	125	83	42	0
12	350	300	250	200	150	100	50	0
14	409	350	292	234	175	117	58	0
16	467	400	334	267	200	133	67	0
18	525	450	375	300	225	150	75	0
20	584	500	417	334	250	167	83	0
22	642	550	459	367	275	183	92	0
24	701	600	500	400	300	200	100	0
26	759	651	542	434	325	217	108	0
28	817	701	584	467	350	234	117	0
30	876	751	626	500	375	250	125	0
32	934	801	667	534	400	267	133	0
34	992	851	709	567	425	284	142	0
36	1051	901	751	600	450	300	150	0
38	1109	951	762	634	475	317	158	0

40	1168	1001	834	667	500	334	167	0
42	1226	1051	876	701	525	350	175	0
44	1284	1101	917	734	550	367	183	0
46	1343	1151	959	767	575	384	192	0
48	1401	1201	1001	801	600	400	200	0
50	1460	1251	1043	834	626	417	209	0



Calculation of the amount of salt

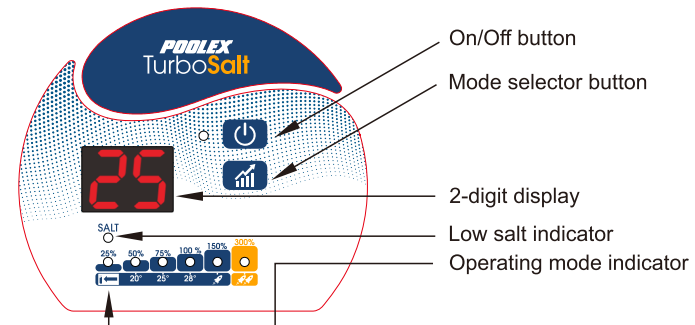

$$\text{Amount of salt to add} = \text{Volume of water in m}^3 \times (3 - \text{current salt content in kg/m}^3)$$

USE

Overview of control panel



On/Off button:
  Turns the chlorinator on or off.
 LED is green when on / red when off.

Low salt indicator:
  Let's you know if salt level is correct
 LED is green if the level is good / otherwise the LED is red (perform a test, then add or remove salt; see previous chapter on correct salt levels)



2-digit display:

Visually displays different information:

Chlorinator status: OFF when switched off

When the chlorinator is on, displays the water temperature by default to make adjustment easier

Mode selected, changes with each press of the mode switch button:

CO: Covered Pool mode
P4: Spring mode
P6: Summer mode

P8: Comfort mode
B1: BOOST 1 mode
B2: BOOST 2 mode



The mode switch button

cycles through operating modes with each press of the button.

During chlorine production, the green LEDs correspond to the mode selected

Once the daily production cycle is complete or if the chlorinator is switched off, the 25% LED will be red.

Production in progress, shown here in summer mode

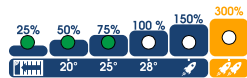

Power status indicator

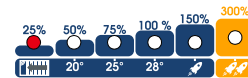

Selecting operating modes



IMPORTANT: The chlorinator will only function when water flow is detected, i.e., when the filtration system is switched on. Filtration time must therefore be sufficiently long for the selected operating mode (preferably one time slot per day during periods of strong sunlight).

Reminder: use the following formula to determine the best setting Filtration time = (T° water)/2



1- Covered Pool Mode (or off-season)

- When covering your pool for more than 3 days, select Covered Pool mode (CO). The chlorinator will only produce chlorine for 2 hours per day.

Chlorine production must be reduced if your pool remains covered for prolonged periods to avoid overproduction. Covered pools are less exposed to organic materials (bacteria, cells), UV rays and other sources of light. As a result, hypochlorite will convert back to salt more slowly.

Overproduction can lead to increased corrosion of the exposed metal surfaces of your pool.

- During the off-season, when water temperatures are higher than 10°C, but do not exceed 20°C, select the Covered Pool (CO) mode. The chlorinator will only produce chlorine for 2 hours per day.



2- Spring Mode

At the start of the season, when water temperatures are higher than 20°C, but do not exceed 25°C (i.e. a recommended filtration time of between 10h and 12h), select Spring mode (P4). The chlorinator will produce chlorine for 4 hours per day. Below 10°C, the chlorinator will not function and will display the following error code: E7.



3- Summer Mode

During the regular season, when water temperatures are higher than 25°C, but do not exceed 28°C (i.e., a recommended filtration time of between 12h and 16h), select Summer mode (P6). The chlorinator will produce chlorine for 6 hours per day.



4- Comfort Mode

During the peak of the season, or if you heat your pool, when water temperatures are higher than 28°C (i.e., a recommended filtration time of between 16h and 24h), select Comfort mode (P8). The chlorinator will produce chlorine for 8 hours per day.



5- BOOST 1 mode

Above these temperatures, during periods of hot weather with water temperature exceeding 30°C (i.e., a recommended filtration time of 24h), or following heavy rainfall, it may be necessary to increase hypochlorite production for a limited period of time. Select BOOST 1 mode (B1). The chlorinator will produce chlorine for 12h over the course of the day and revert to Comfort Mode (P8) the following day.



6- BOOST 2 mode

During periods of extremely hot weather, with water temperatures exceeding 30°C (i.e., a recommended filtration time of 24h), and/or with intensive use of the pool, it may be necessary to produce even more chlorine for a limited period of time. Select BOOST 2 mode (B2). The chlorinator will produce chlorine for 24h over the course of the day and revert to Comfort Mode (P8) the following day.

These are preset modes and will restart daily at their selected time. Depending on the usage and conditions of your pool (volume, exposure to plant material, sunlight, etc.), it may be necessary switch to a higher or lower mode.

TROUBLESHOOTING



WARNING: If the water has turned green after winterizing your pool, or during periods of extremely high temperatures, the chlorinator alone will not be sufficient to clear up green water. Intermittent use of chlorine tablets may be necessary. Do not put the chlorine tablets directly into the skimmer; use a floating dispenser. If you need to use a chlorine shock treatment, switch off the chlorinator beforehand to prevent damage to the cell.

Performing system checks

Even though we take every necessary precaution when manufacturing the chlorinator, breakdowns are still possible. In the event of a defect and/or malfunction, electrical power must be switched off and no attempts to repair the fault should be made. Repairs must be carried out by an authorised technician using original spare parts. Not complying with the aforementioned clauses can negatively impact the safe operation of the chlorinator.

However, other underlying factors may also affect the treatment efficiency of the chlorinator, such as issues with water quality (water starting to turn green); please follow the steps below to help with troubleshooting.

Here are some steps to take in order to verify if your chlorinator is malfunctioning:

Check that it is plugged in

Check that the power is still on and if the residual current device has tripped (or the upstream circuit breaker); in case of doubt, contact a professional.

Check that the filtration time is sufficiently long: Filtration time = (T° water)/2

To obtain optimal treatment, we recommend selecting the appropriate mode for the temperature of your water, and to use the two BOOST modes in case of high temperatures and intensive use (see section on selecting operating modes). These are preset modes and will restart daily at their selected time. Depending on the usage and conditions of your pool (volume, exposure to plant material, sunlight, etc.), it may be necessary switch to a higher or lower mode.

TROUBLESHOOTING

In addition, depending on the mode, the minimum daily filtration time must be respected:

Mode	Covered C0	Spring P4	Summer P6	Comfort P8	BOOST 1 B1	BOOST 2 B2
T° water	10°C ≤ T° < 20°C or covered pool	20°C ≤ T° < 25°C	25°C ≤ T° < 28°C	T° ≥ 28°C	T° ≥ 28°C or intensive use	T° ≥ 30°C or intensive use
Treatment time	2h	4h	6h	8h	12h	24h
Filtration time	5h to 10h	10h to 12h	12h to 16h	16h to 24h	24h	24h



WARNING: If you split your daily filtration time into multiple time slots, we recommend the slot used for treatment is sufficiently long to cover the entire length of the treatment.

These are preset modes and will restart daily at their selected time.

Check that the parameters of the water are correct (salinity, stabiliser level, pH and if necessary hardness and alkalinity)

Check that the water flow rate is sufficient (> 2 m³) and/or not too high (< 10 m³)

If you are still encountering issues, your chlorinator may be malfunctioning. The chlorinator also has a self-test function which will display error codes in the event of a problem (see next page).

TROUBLESHOOTING

Error codes and fixes

Error code	Description of error	Comments	Solutions
E2	Water temperature is outside of normal operating range	The normal operating range for water temperature is between 10°C to 45°C	<ul style="list-style-type: none"> - If the water temperature of your pool is below 10°C, consider winterizing your device. - If the water temperature of your pool is above 45°C, switch off the chlorinator and wait for the temperature to drop to the normal operating range. - If the actual temperature of the water is within the normal operating range, check if error code E3 or E7 is also displayed (see section on errors E3 and E7 below).
E3	Water flow not detected	The normal operating range for flow rate is between 2 m ³ /h to 10 m ³ /h	<p>Check the following:</p> <ul style="list-style-type: none"> -The filtration time is sufficiently long to encompass the entire length of the treatment. Please note: if the daily filtration time is split into multiple time slots, and these time slots are shorter than the treatment time, this error may temporarily appear during downtime between slots and will last until the full treatment cycle has completed in subsequent slot(s). -The bypass is providing enough water to the cell and the valves are correctly set. -The filter is not clogged/obstructed (clean if necessary) -The flow rate of the rate is sufficient -The presence of debris/scale deposits in the cell may obstruct the flow sensor (clean if necessary following the steps provided in the next page) <p>If all of the steps above have been followed and the error persists, contact customer service for a replacement flow sensor.</p>
E5	Salt concentration is too low	The normal operating range for salt concentration 2,700 to 4,500 ppm	<p>Test the salt concentration of the water.</p> <p>If necessary, add salt until reaching 3 g/l; ensure the chlorinator is switched off until the salt has fully dissolved (see section on dissolution above).</p> <p>Once the correct level has been reached, the chlorinator should operate normally again.</p>
E7	Fatal error in temperature sensor		Contact customer support for a replacement temperature sensor.
E8	Transformer output voltage error		Contact customer support for a replacement transformer.

TROUBLESHOOTING

Error codes and fixes

Error code	Description of error	Comments	Solutions
E9	Output current error		Contact customer support for a replacement transformer or cell.
EA	Cell error		Test salt concentration and correct if necessary. If the error persists: Contact customer support for a replacement cell.
EC	Electronics error		Unplug the transformer, wait one minute, then plug back in. If the error persists: Contact customer support for replacement circuit boards.

Cleaning the cell

To maintain optimal performance of your chlorinator, the cell should be inspected at least once every 3-4 months (there should be no debris obstructing the flow sensor or between the electrode plates).

The cell has a self-cleaning function which uses reverse polarity. In most cases, this self-cleaning function will keep the cell operating efficiently and will prevent formation of scale deposits.

The cell should be cleaned once or twice per season.

In areas where the water is very hard (i.e., high calcium concentration), or in pools with poorly balanced water, the cell may require additional cleaning.

This chlorination process which creates chlorine (hypochlorite) from salt naturally leads to the formation of mineral deposits on the titanium electrodes of the cell. The reverse polarity selfcleaning function helps prevent these deposits and scale formation. If the water is very hard, with a high degree of general hardness, the formation of deposits is inevitable and these deposits must be removed.

To clean the cell:

Disassembly:

Shut off the power supply and close any return valves.

Unplug the power cable from the transformer.

Unscrew the threaded nuts around the PVC connectors which connect the cell to the piping.

Remove any residual water (drain into a receptacle and put it back into the pool).

Completely remove the union fittings from the cell. DO NOT pull or carry the cell by its power cable.

Attention: unscrewing the grey mounting nut from the control box will void the warranty.

TROUBLESHOOTING

Cleaning:

Always use a descaling agent intended for use in a salt chlorinator cell; follow the instructions and safety recommendations of the manufacturer.

Follow the steps below to disassemble the cell:

Using a pipe end cap (e.g. product ref. CL-TSLCAP - no provided), plug one opening and hold the cell upright, with the end cap at the bottom.



Pour the descaling agent directly into the cell until it covers all of the deposits. Once the electrode plates have been completely submerged, wait 10 to 20 minutes (depending on the brand and quantity of scaling to be removed), periodically agitating the liquid in the cell.

Check that all scale deposits have been removed. Perform these steps again if necessary.

Once all scale deposits have been removed, rinse and reassemble the cell.

Using an inappropriate or highly concentrated product (pure acid) can cause visible and irreversible damage to the cell not covered by the warranty and could be potentially dangerous.



When cleaning the cell, always wear appropriate protective equipment such as rubber gloves and eye protection.

Always work in a well-ventilated area. Acid splashes can lead to serious injury and/or property damage.

Never add water to acid.

Replacing the cell

Once the titanium plates inside the chlorinator cell have reached the end of their service life (after around 7,000h), they can be replaced. To guarantee quality and value, only use original spare parts. If necessary, bypass tubes can be used to allow water to continue circulating in the pipework once the cell has been removed. See chapter on winterizing (Winterizing tube product ref. CL-TSLTUBE)

WINTERIZING

Active winterizing

When temperatures are low, very little chlorine is required. If actively winterizing your pool, the Covered Pool mode will be sufficient.

However, the chlorinator will not produce chlorine below 10°C and will display an error code (E2); this feature prolongs the service life of the cell.

If water temperature continues to decrease until freezing, the cell and plumbing of your pool will be damaged by the freezing water.

Before first frost, as a precautionary measure, disconnect the cell (following the steps above) by closing the bypass to isolate the circuit. Store your cell in a dry place.

If a bypass is not in place, replace the cell with the winterizing tube (product ref CL-TSLTUBE - no provided). Store your cell in a dry place.

Passive winterizing

In areas subject to periods of prolonged or extreme cold, before first frost, ensure that all water has been removed from the pump, filter, as well as the water supply and return lines.

As a precautionary measure, disconnect the cell (following the steps above) by closing the bypass to isolate the circuit and store your cell in a dry place.

If a bypass is not in place, replace the cell with the winterizing tube (product ref CL-TSLTUBE - no provided). Store your cell in a dry place.



Restarting in spring

When operating pool equipment for the first time after long periods of inactivity, do not switch on the chlorinator until the water has been balanced, in particular pH and salt concentration, and optimal levels have been reached (namely, pH between 7.0 and 7.4 and salt concentration of 3.5 g/l).

This is also a good time to test the other parameters mentioned at the beginning of this user guide.



WARNING: If the water has turned green after winterizing your pool, or during periods of extremely high temperatures, the chlorinator alone will not be sufficient to clear up green water. Intermittent use of chlorine tablets may be necessary. Do not put the chlorine tablets directly into the skimmer; use a floating dispenser.

If you need to use a chlorine shock treatment, switch off the chlorinator beforehand to prevent damage to the cell.

USEFUL TIPS

General principles

Correct operation of the chlorinator can be easily verified by checking the lights on the control panel. However, if the pool remains cloudy and tests show low levels of residual chlorine, the chlorine produced may have been lost due to high chlorine demand or improper water conditions.

To reduce chlorine demand:

Check pH levels (between 7.0 and 7.4)

Check stabiliser levels (Cyanuric Acid) are between 20 to 50 ppm

Check for the presence of phosphates and nitrates which increase overall chlorine demand

If these tests are positive, an oxidizer shock treatment is recommended.

In general, BOOST modes are not required if the pool is maintained at the correct levels.

List of Recommended Actions:

Read the manual and keep in a safe place for future reference.

Adjust chlorine production when temperatures increase or decrease (select the right mode).

Increase chlorine production when bathing load increases (see BOOST modes).

Use a stabiliser (Cyanuric Acid) at concentrations of 20 to 50 ppm to protect the free chlorine in the pool.

Where possible, install the chlorinator out of direct sunlight.

Regularly get a water sample tested by a qualified pool professional.

Maintain salt concentration levels around 3.5 g/l (3,500 ppm).

Regularly test the parameters of the water.

List of Prohibited Actions:

Do not use fertiliser close to your pool. Fertilisers are an abundant source of Nitrates and Phosphates, resulting in higher chlorine demand and deposits on the chlorinator cell.

Never use pure acid to adjust the pH. Deposits of by-products can damage the cell.

Do not add any chemicals to the water (including salt) when the chlorinator is switched on (switch it OFF).

Do not add chemicals (including salt) directly into the skimmer.

Do not allow salinity to fall below 3 g/l (3,000 ppm).

USEFUL TIPS

SUPPLEMENTARY ELECTRICAL BONDING (POOL EARTHING)

In order to protect the metal components (including stainless steel) in contact with the water of your pool, it is strongly recommended to install supplementary bonding (POOL EARTHING) (product ref. CL-POOLTERRE50 - not supplied) which is separate from the earthing system of your house in order to carry residual current from your pool equipment to the ground. This current can lead to serious galvanic corrosion. (Ground cable not supplied)



WARRANTY

The Turbo Salt salt chlorinator is guaranteed free of any material or manufacturing defects, for normal use and non-commercial applications, for a period of Three (3) years or 7,000 h, subject to the following conditions:

Proof of purchase is required.

This limited warranty extends exclusively to the original purchaser of the chlorinator system and is non-transferable.

The Turbo Salt salt chlorinator is intended for use in private pools and any commercial use voids this warranty.

Three (3) years or 7,000 hours limited warranty on generator housing and cell.

This warranty does not apply to the following situations:

- Faults or damage arising from installation, use or repairs which do not comply with the safety instructions.
- Faults or damage arising from improper use of the chlorinator pursuant to the manufacturer's recommendations, as set out in this User Guide.
- Faults or damage arising from an improper chemical environment in the pool.
- Faults arising from failure to maintain the chemical properties of the pool at the appropriate levels, in accordance with the manufacturer's recommendations, as set out in this User Guide.
- Faults or damage arising from sabotage, accidents, electrical surges, abuse, negligence, unauthorised or unqualified repairs, alterations to the product, or damage due to fire, floods or frost, acts of God or force majeure.
- Faults or damage arising from unintended use of the device.
- Damage arising from negligence, accidents or force majeure.
- Faults or damages arising from the use of unauthorised accessories.
- Damage or deterioration of concrete, natural stone, wood or synthetic surfaces nearby the pool.

WARRANTY

Legal disclaimer: this limited warranty constitutes the entire warranty.

No other guarantees apply, explicit or implicit. This limited warranty grants specific legal rights which may vary by jurisdiction. Under no circumstances shall we be liable for consequential damage(s), special or indirect, regardless of nature, including but not limited to physical injury, property damage, or damage or loss of equipment. The agent / installer shall not be liable for any costs arising from installation or maintenance.

Repairs undertaken during the warranty period must be approved before being carried out by a certified technician. This warranty is voided in the event of repairs to the device made by individuals which have not been authorised by Poolstar.

The parts under warranty shall be replaced or repaired at the discretion of Poolstar. Faulty parts must be returned to us during the warranty period in order to be covered by the warranty. The warranty does not cover unauthorised replacements or labour costs. Delivery costs for returning the faulty part are not covered by the warranty.

**Do you have
A question? A problem? Or if you simply want to register your warranty,
head over to our website:**

<http://support.poolex.fr/>

**Thank you for your trust and support.
Happy bathing!**

Your personal information is processed in accordance with the French Data Protection Act of 06 January 1978 and will not be shared with 3rd parties.