

CARACTERÍSTICAS TÉCNICAS | Technical Characteristics

MATERIAL Aço
 Plástico reciclado
 ACABAMENTO Metalizado e pintado
 COLOCAÇÃO Sobre base rígida
 PESO Aprox. 59 Kg

MATERIAL Steel
 Recycled plastic
 FINISH Metallized and painted
 FIXING Set to rigid base
 WEIGHT Aprox. 59 Kg



DESIGN AMOP

Dimensões (mm)

DESENHO TÉCNICO | Technical Drawing

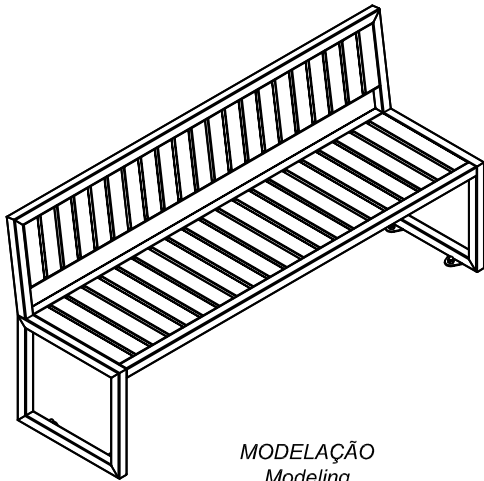

MODELAÇÃO
Modeling

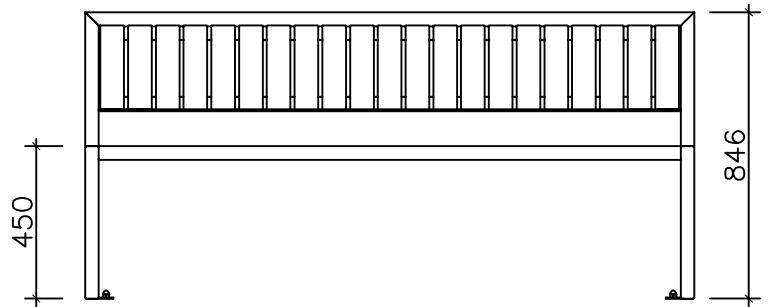

ALÇADO FRONTAL
Front View

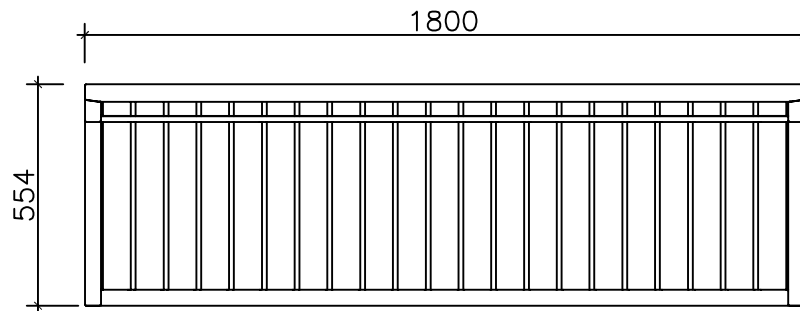

PLANTA
Top View

SUSPENSÃO, APLICAÇÃO E CARACTERÍSTICAS ESPECIAIS | Suspension, Application and Special Features

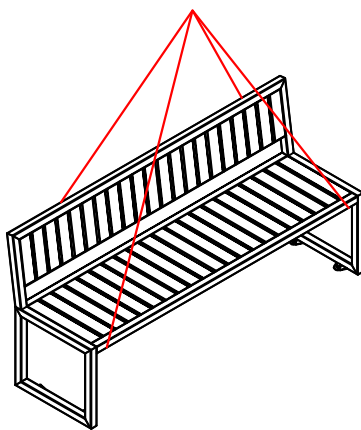

SUSPENSÃO COM CINTAS EM POLYESTER, ACESSÓRIOS E PROTEÇÕES ADEQUADAS.
 ANGULO DE TRACÇÃO DAS CINTAS EM POLYESTER > 60°
 Suspension with polyester slings, tools and appropriate protections.
 Polyester slings traction angle > 60°

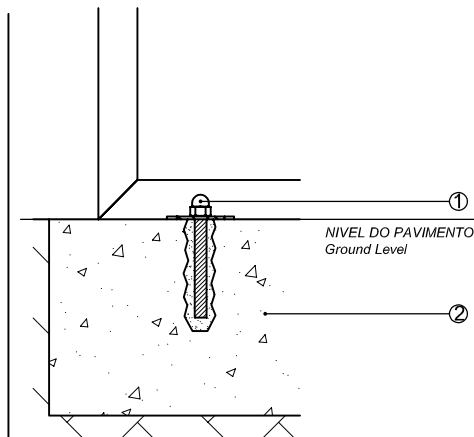

1- PERNO ROSCADO M12 E RESINA EPOXY
 M12 threaded rod and epoxy resin
 2- FIXAÇÃO EM BASE RÍGIDA
 Set to rigid base

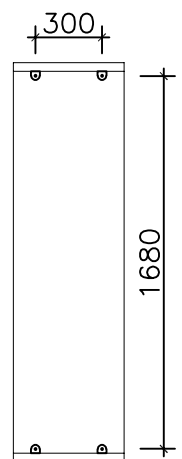

CADEIRA COLETIVA 3A - LINHA SCREEN

AMP.019/00 EDIÇÃO 0 DATA: 01/02/2021

amop®
 synergies

APARTADO 38 3754-906 AGUADA DE BAIXO ÁGUEDA - PORTUGAL
 TEL 234667957 FAX 234666908
 geral@grupoamop.com www.grupoamop.com

REF.^a - 34014

FT.34014 Folha | Page 1-1