

## CARACTERÍSTICAS TÉCNICAS | Technical Characteristics

MATERIAL Aço  
 Plástico reciclado  
 ACABAMENTO Metalizado e pintado  
 COLOCAÇÃO Sobre base rígida  
 PESO Aprox. 19 Kg

MATERIAL Steel  
 Recycled plastic  
 FINISH Metallized and painted  
 FIXING Set to rigid base  
 WEIGHT Aprox. 19 Kg



DESIGN AMOP

Dimensões (mm)

## DESENHO TÉCNICO | Technical Drawing

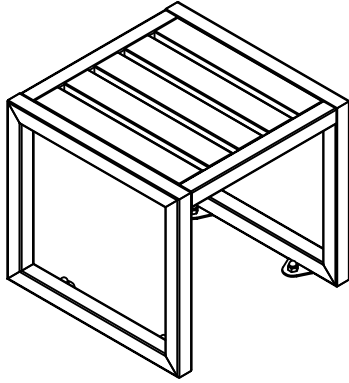

MODELAÇÃO  
Modeling

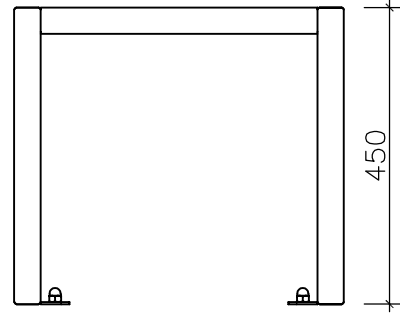

ALÇADO FRONTAL  
Front View

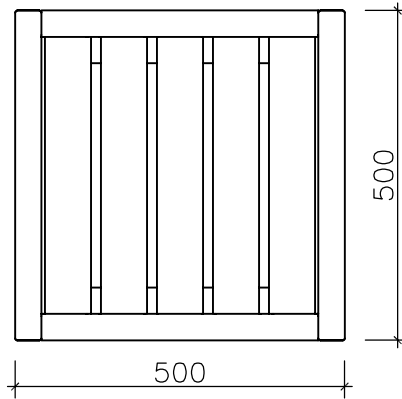

PLANTA  
Top View

## SUSPENSÃO, APLICAÇÃO E CARACTERÍSTICAS ESPECIAIS | Suspension, Application and Special Features

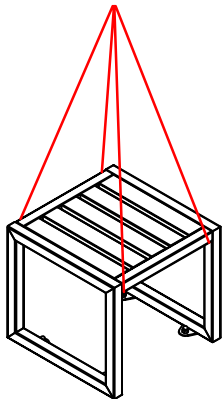

SUSPENSÃO COM CINTAS EM POLYESTER, ACESSÓRIOS E PROTEÇÕES ADEQUADAS.  
 ANGULO DE TRACÇÃO DAS CINTAS EM POLYESTER > 60°  
 Suspension with polyester slings, tools and appropriate protections.  
 Polyester slings traction angle > 60°

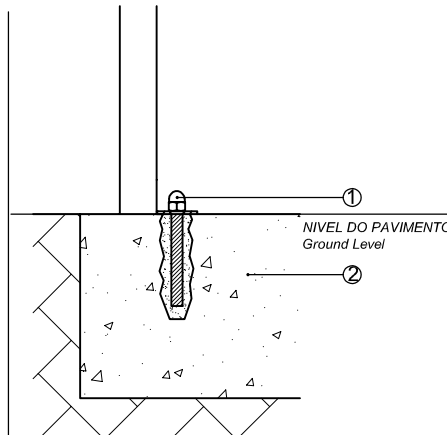

1- PERNO ROSCADO M12 E RESINA EPOXY  
 M12 threaded rod and epoxy resin  
 2- FIXAÇÃO EM BASE RÍGIDA  
 Set to rigid base

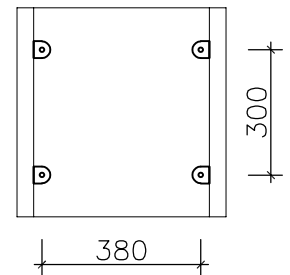

## BANCO INDIVIDUAL 3A - LINHA SCREEN

AMP.019/00 EDIÇÃO 0 DATA: 01/02/2021

amop®  
 synergies

APARTADO 38 3754-906 AGUADA DE BAIXO ÁGUEDA - PORTUGAL  
 TEL. 234667957 FAX 234666908  
 geral@grupoamop.com www.grupoamop.com

REF.<sup>a</sup> - 34011

FT.34011 Folha | Page 1-1