

aykah.

ASSEMBLY SHEET

The Parts at the back
of the Headboard. Please
Open the Black Non
Waven Fabric to find

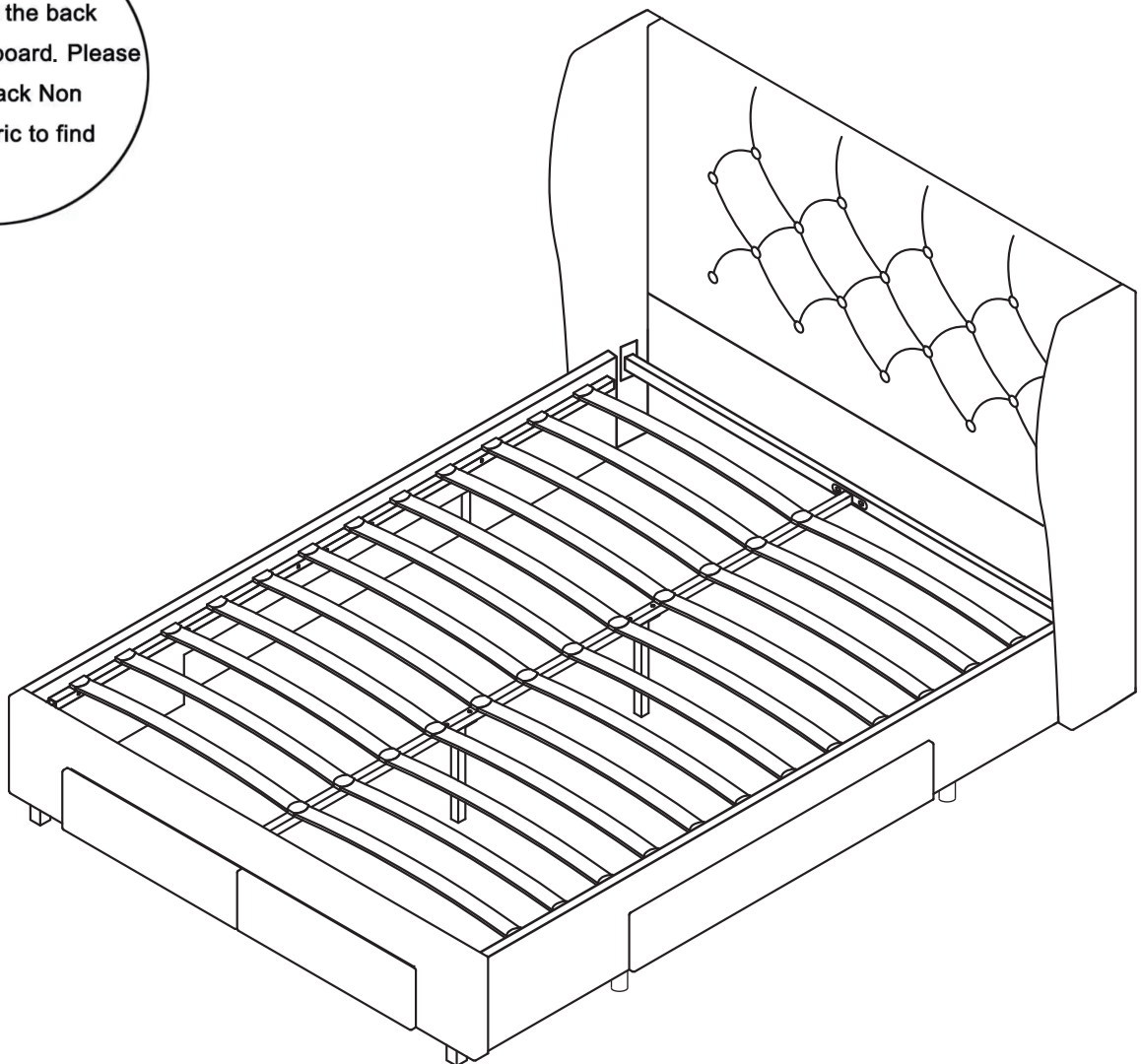

BRITTANY



No. of People: 2

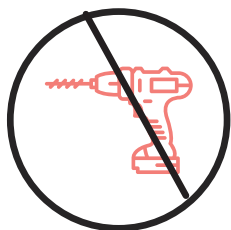

NO power tools required.

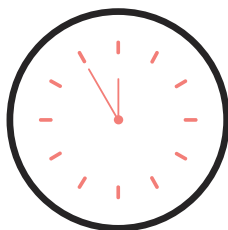

Time: 2 hours



Use a damp cloth to clean.

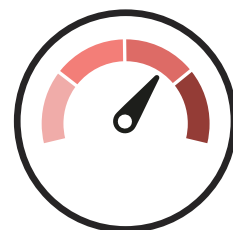









Level of difficulty: 3/4





ASSEMBLY INSTRUCTIONS



Thank you for making a purchase with Aykah. The goal of this assembly sheet is to help you assembly the product in a way that will contribute to its longevity and durability. Kindly follow all the instructions carefully to ensure a safe and accurate assembling process.







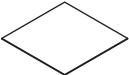
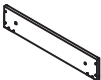
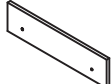
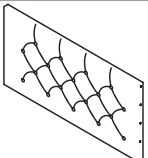
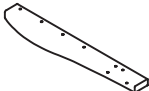
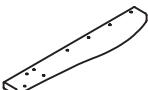
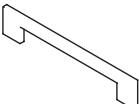
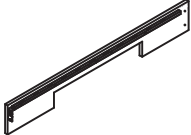

A few important things to note:

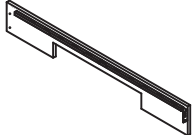
- Please do not use a power tool to assemble this product. Using one may hinder and/or damage the item and will invalidate any claims for warranty.
- Depending on the amount of use this product receives, it may be recommended to tighten up the fixings from time to time. This is completely normal!
- Do not drag the bed. Always lift with at least two people to avoid injury or damage.

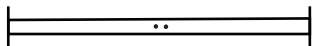
PARTS INVENTORY			
ID	DESCRIPTION		QTY
A	M8*35 BOLT		32
B	M8*65 BOLT		6
C	M4*12 BOLT		64
D	M4*45 BOLT		64
E	WHEELS		16
F	NUT		6
G	SPRING WASHER		4
H	FLAT WASHER M8		32

PARTS INVENTORY			
ID	DESCRIPTION		QTY
I	WHITE PIN		64
J	ALLEN KEY		1
K	OPEN SPANNER		1
L	OPEN SPANNER		1

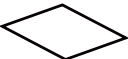
PARTS INVENTORY		
ID	DESCRIPTION	QTY
1	Right and Left Side Drawer 	8
2	Back Side Drawer 	4
3	Bottom Drawer Support 	8
4	Bottom Drawer Base 	4
5	Front Side Drawer 	4
6	Fabric Front Drawer 	4
7	Headboard 	1
8	Right Wings 	1
9	Left Wings 	1
10	Footboard 	1
11-1	Right Siderails 	1

PARTS INVENTORY		
ID	DESCRIPTION	QTY
11-2	Left Siderails 	1
12	Center Frame 	1
13	Center Floating Leg 	2
14	Side Rail Connector 	1
15	Frame Legs 	2
16	Single Close Ended Clip 	30
17	Wood Slat 	30
18	Double Open-Ended Clip 	15
19	Headboard Back Nonwoven Cloth 	1
20	Siderail Leg 	4

STEP 1

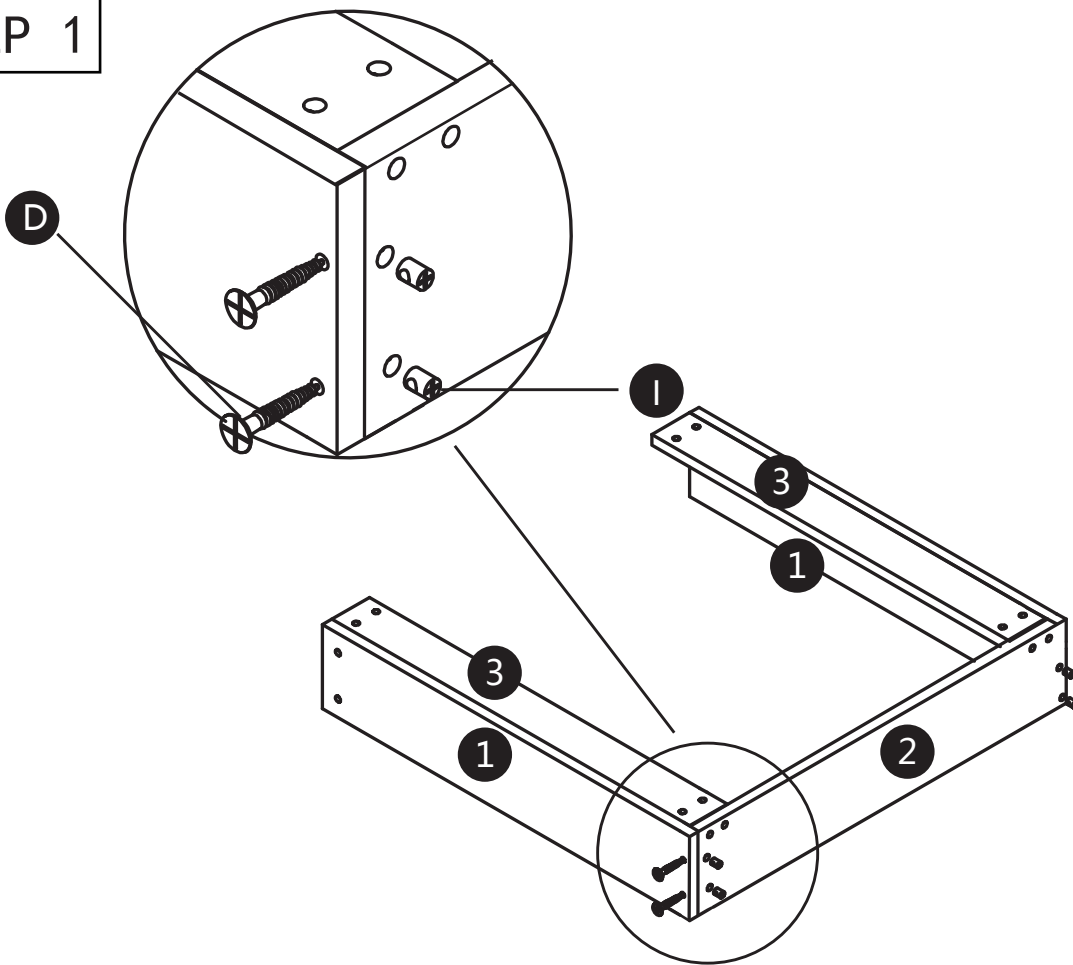

STEP 2

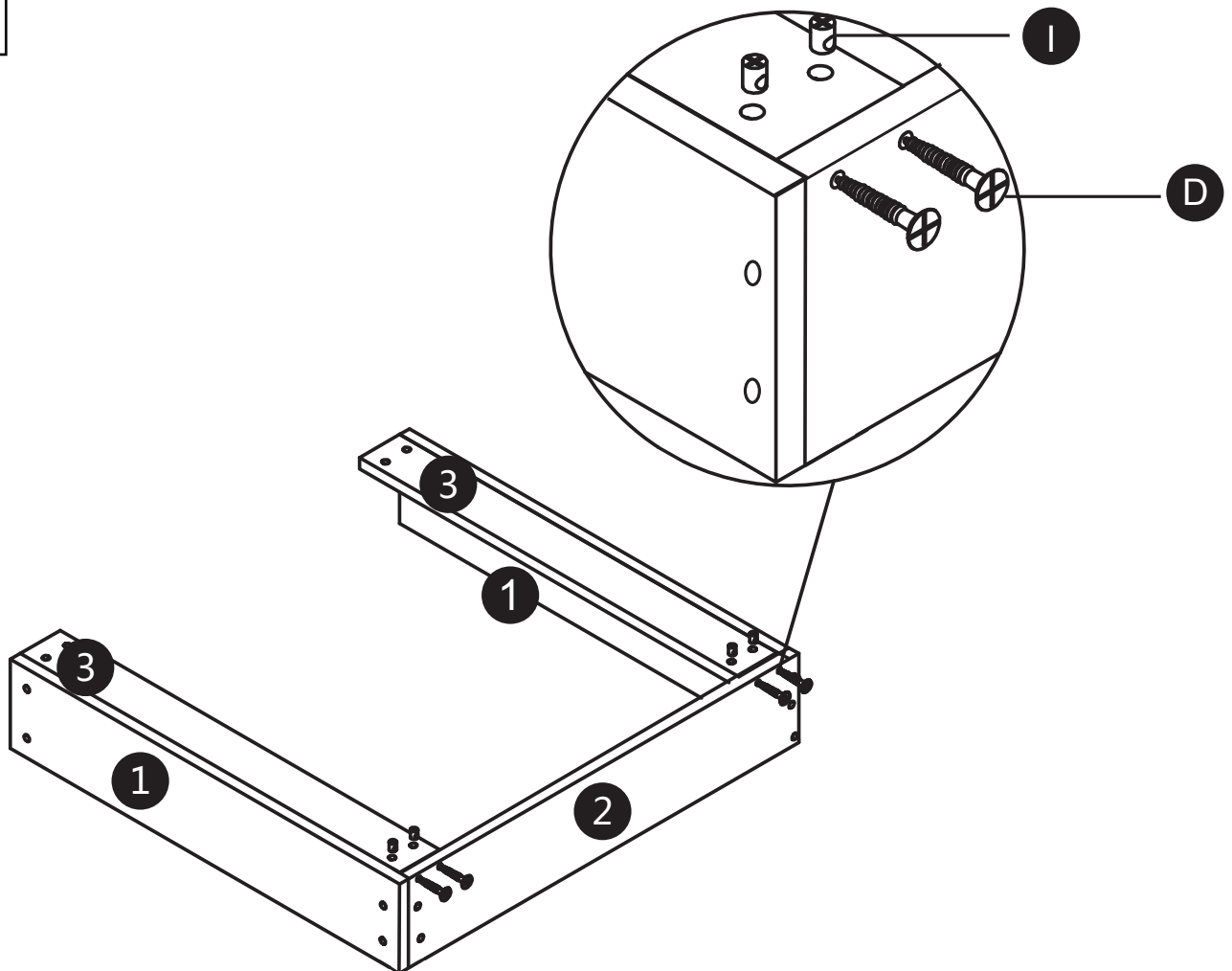

STEP 3

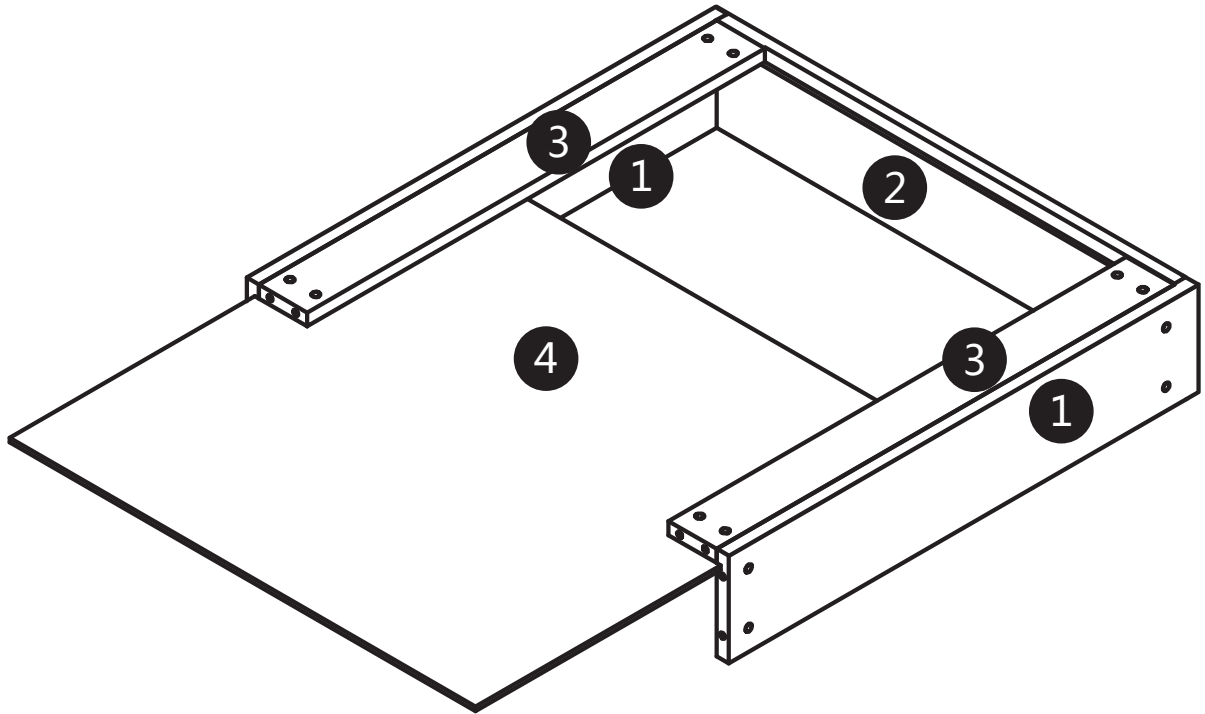

STEP 4

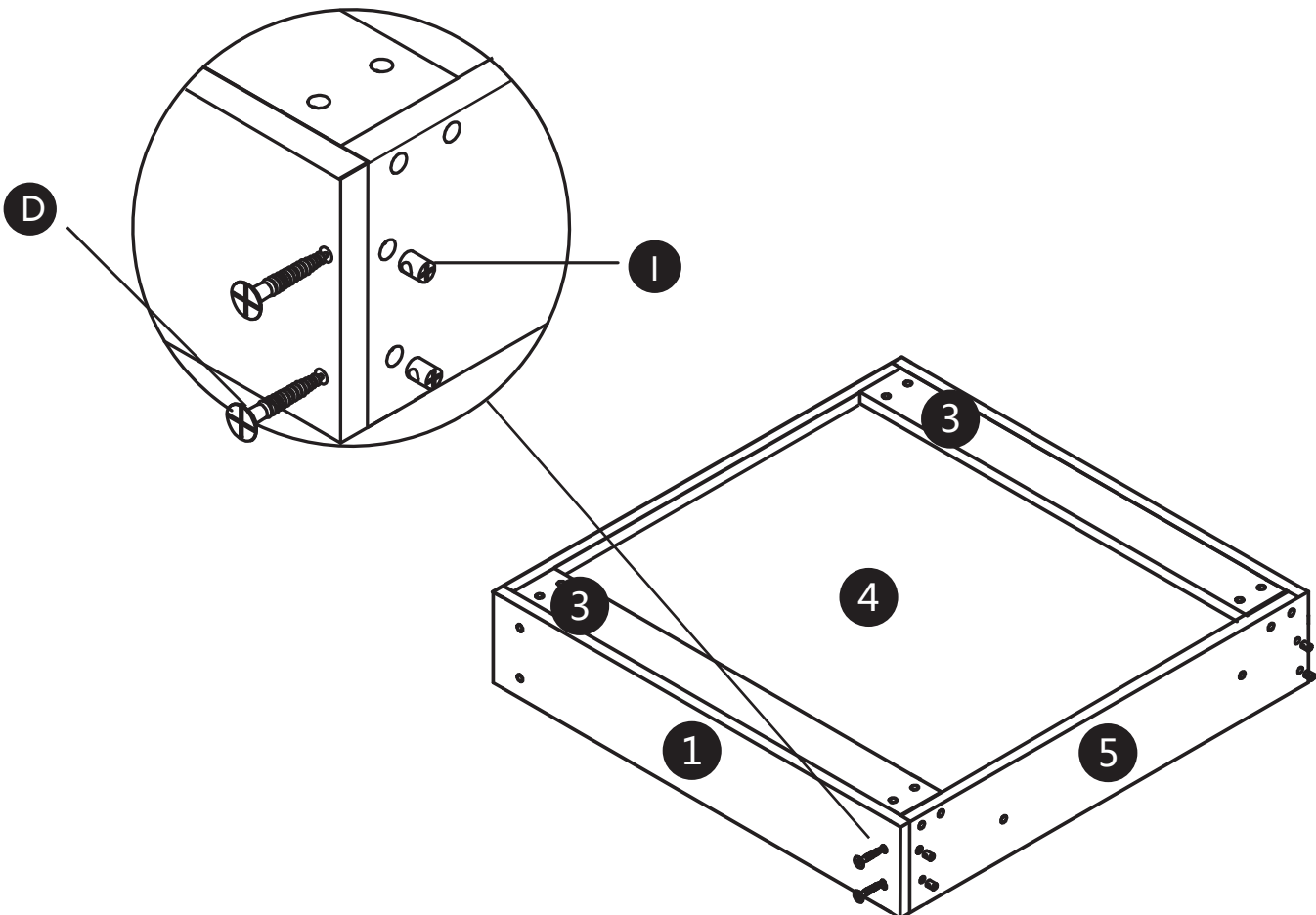

STEP 5

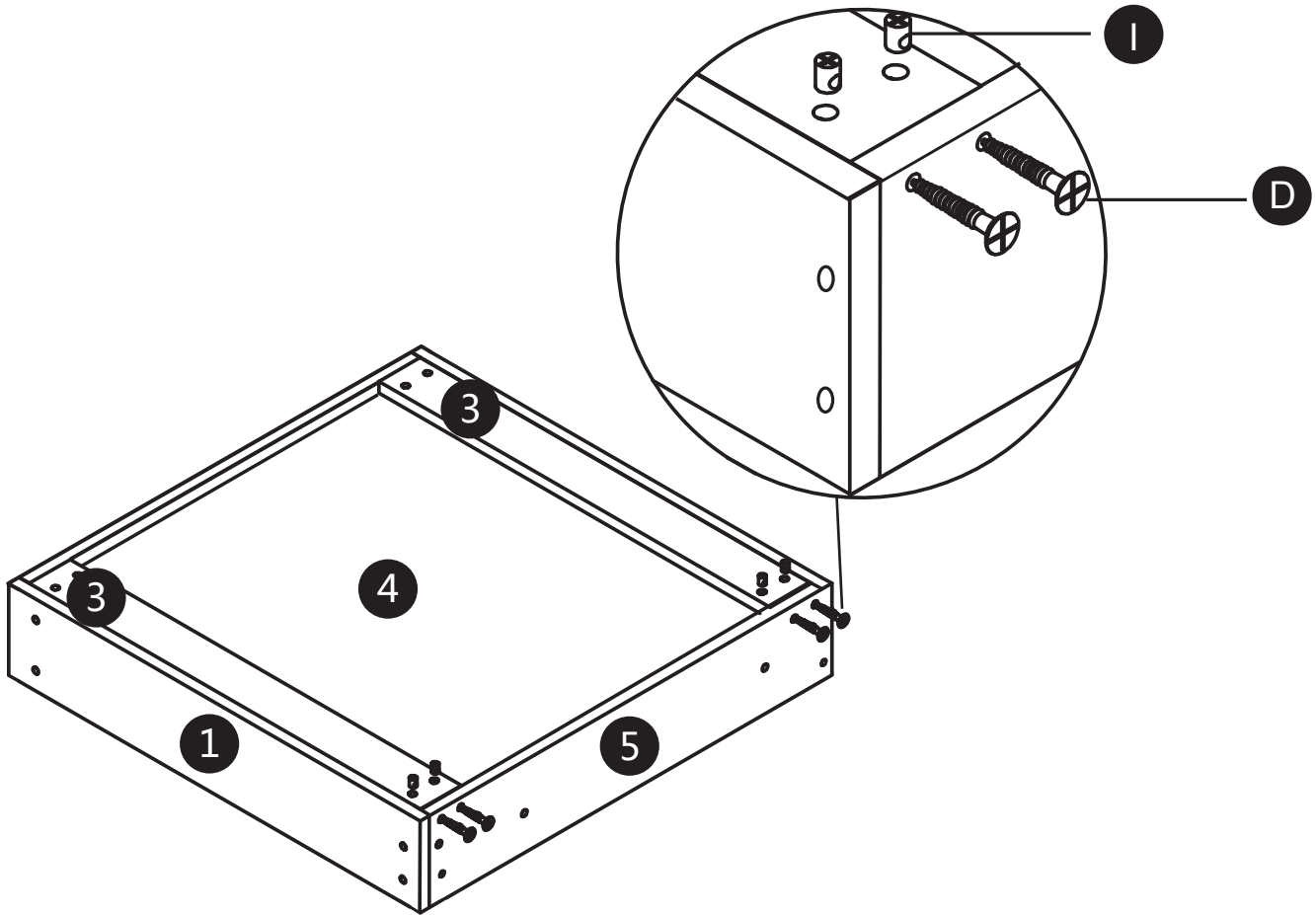

STEP 6

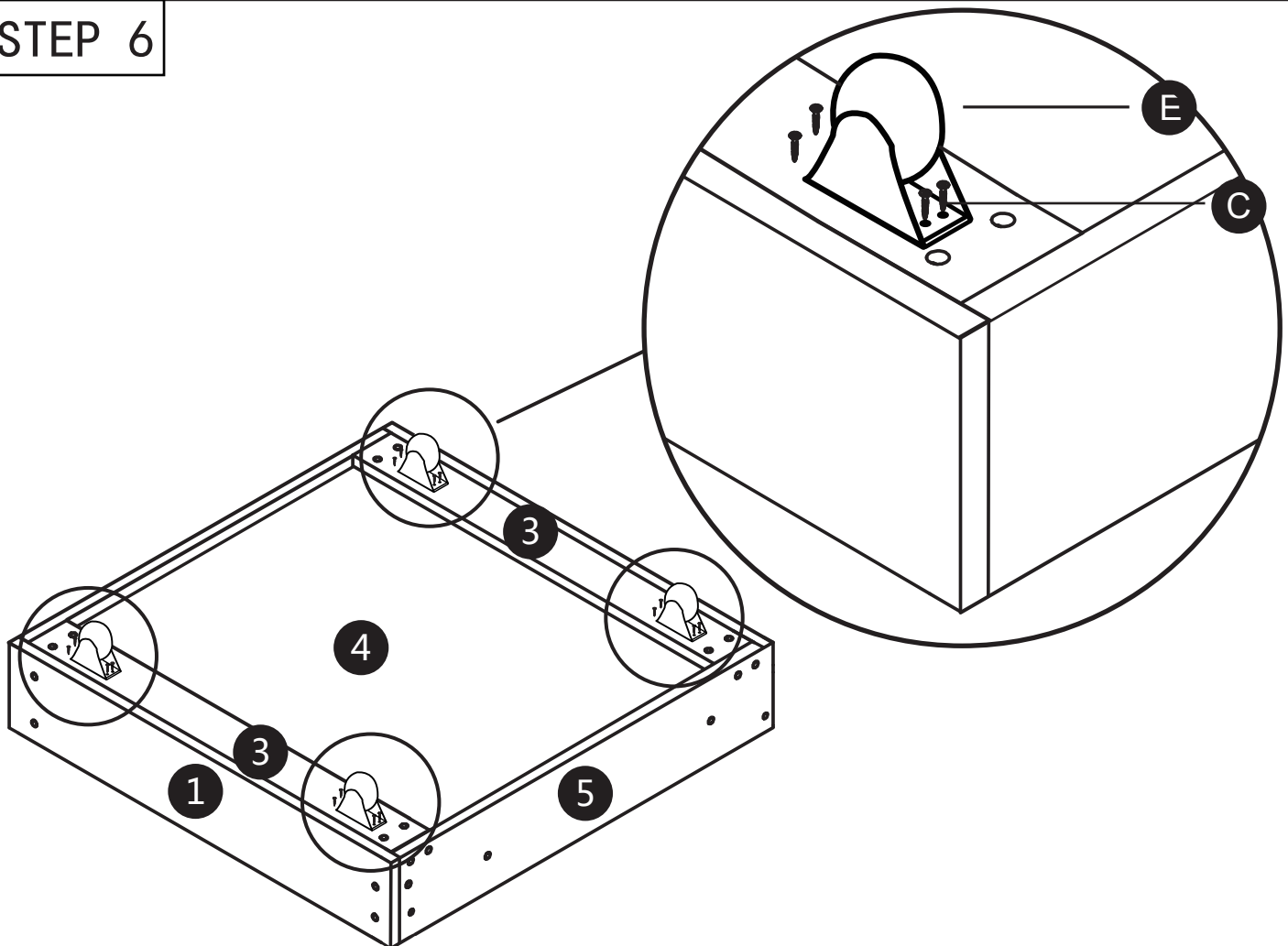

STEP 7

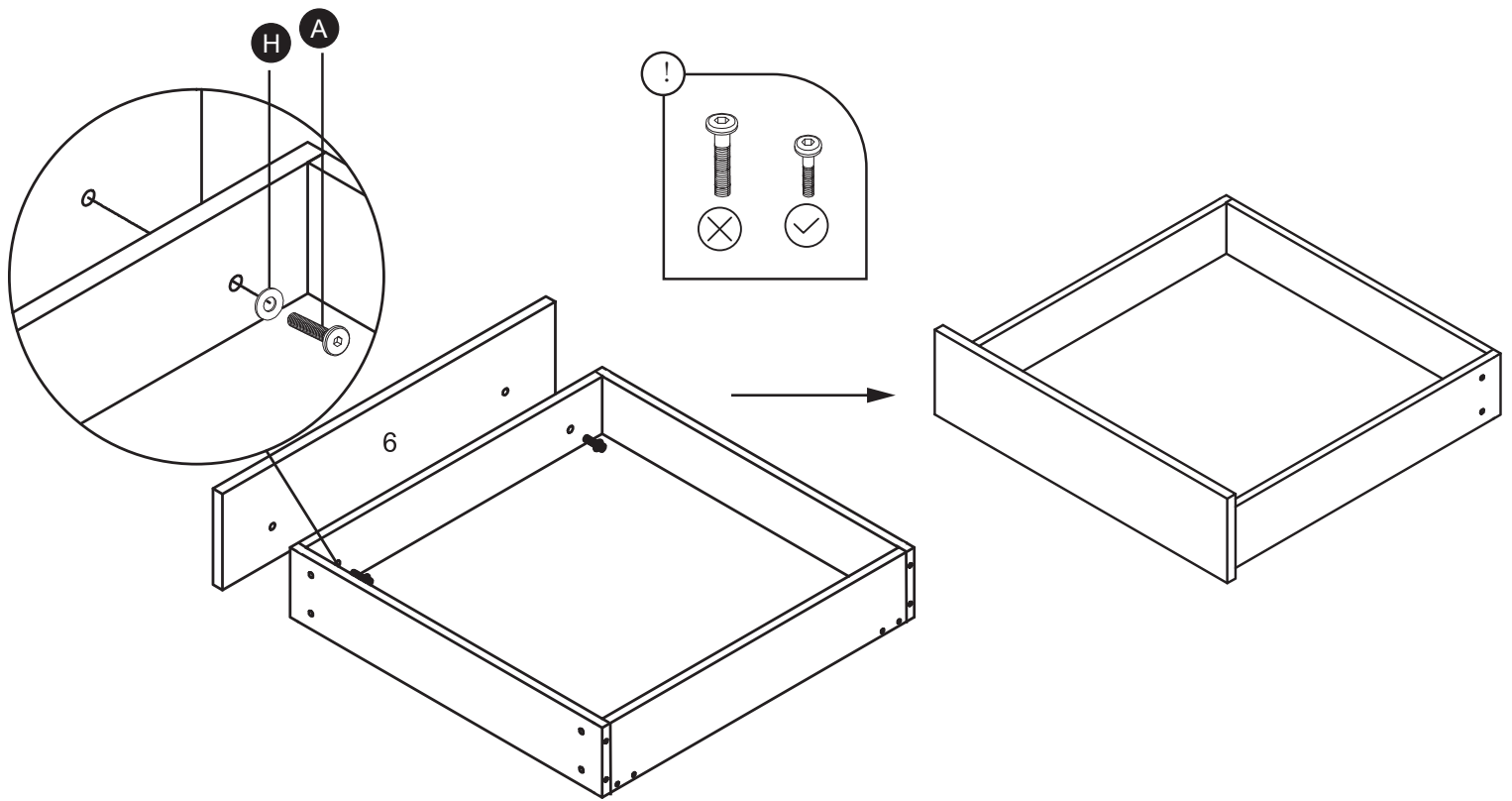

STEP 8

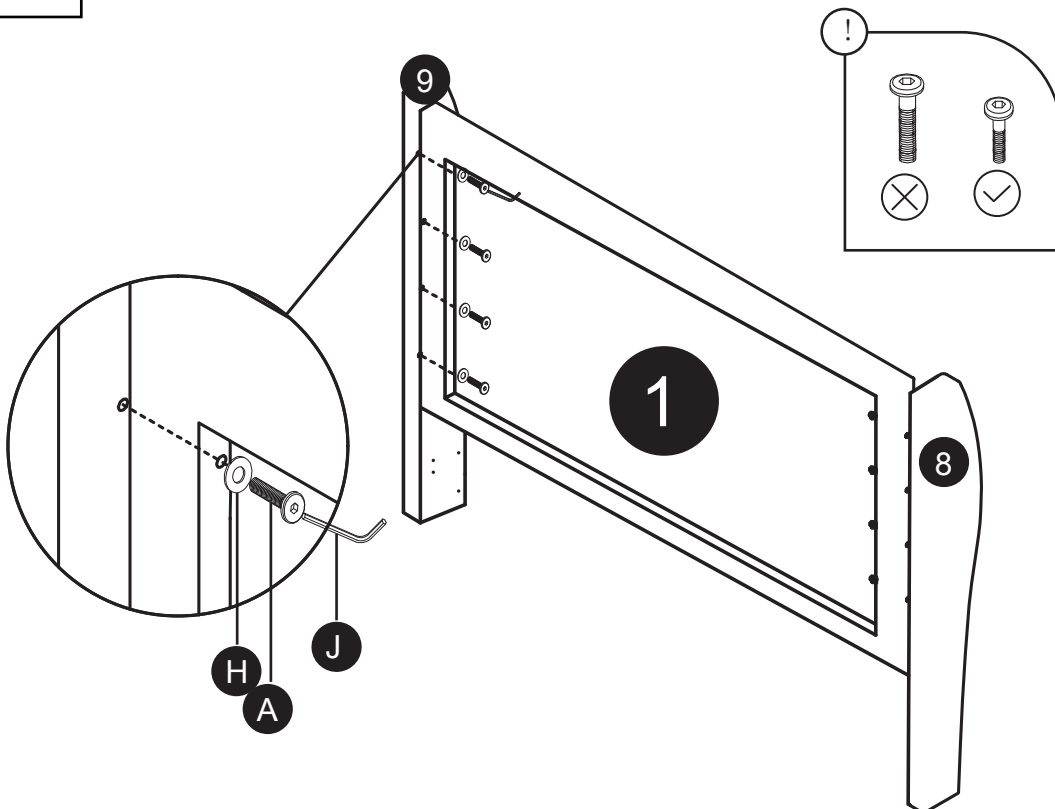

STEP 9

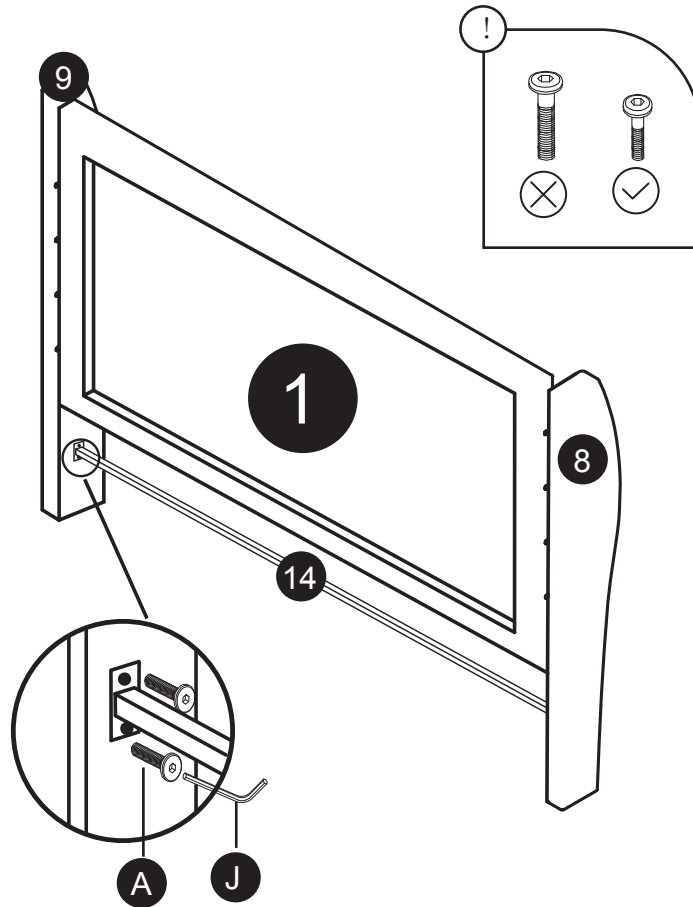

STEP 10

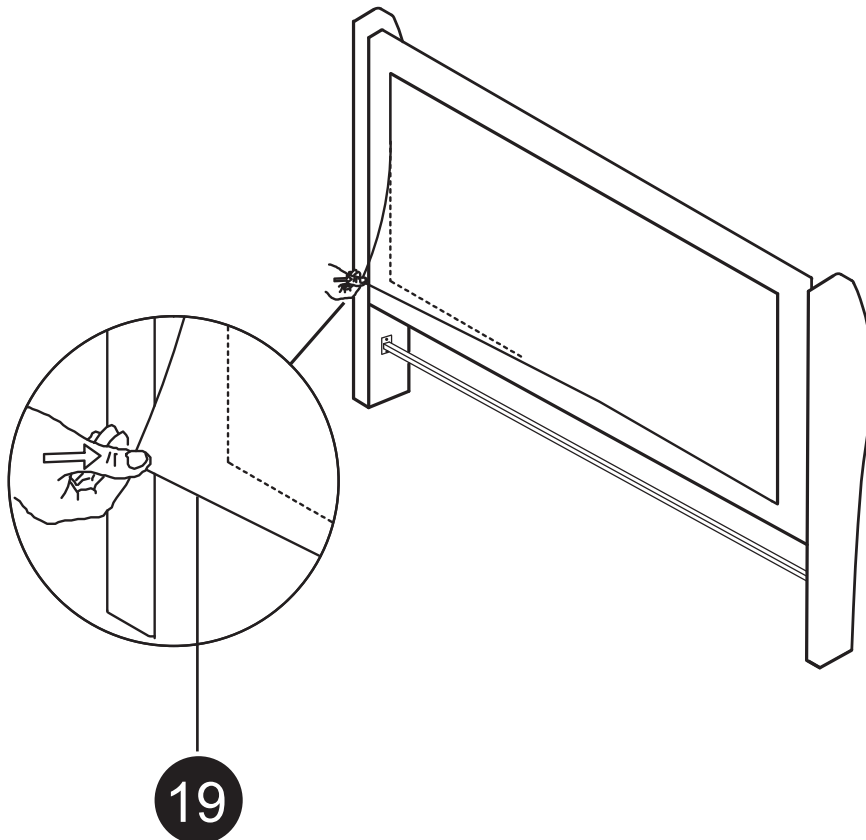

STEP 11

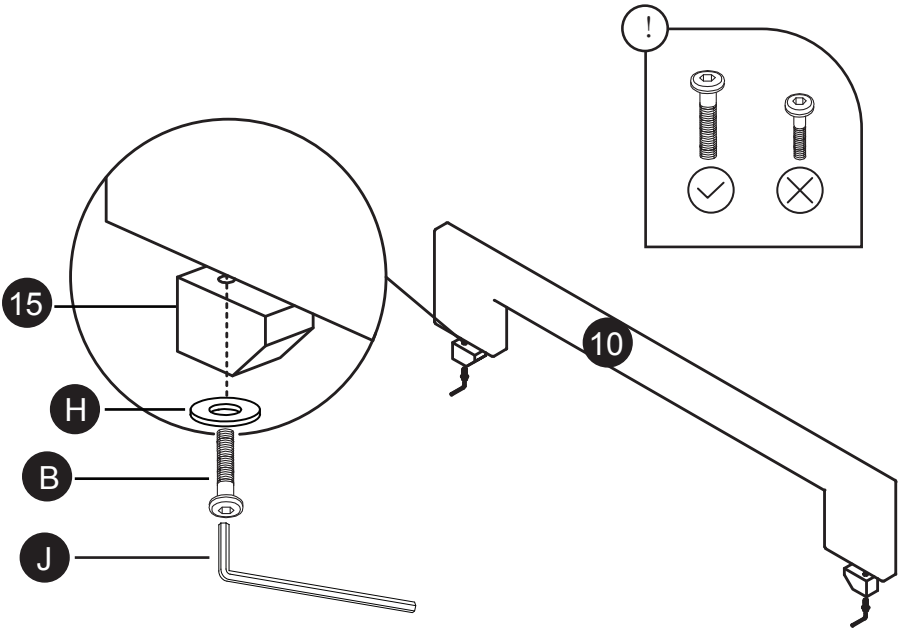

STEP 12

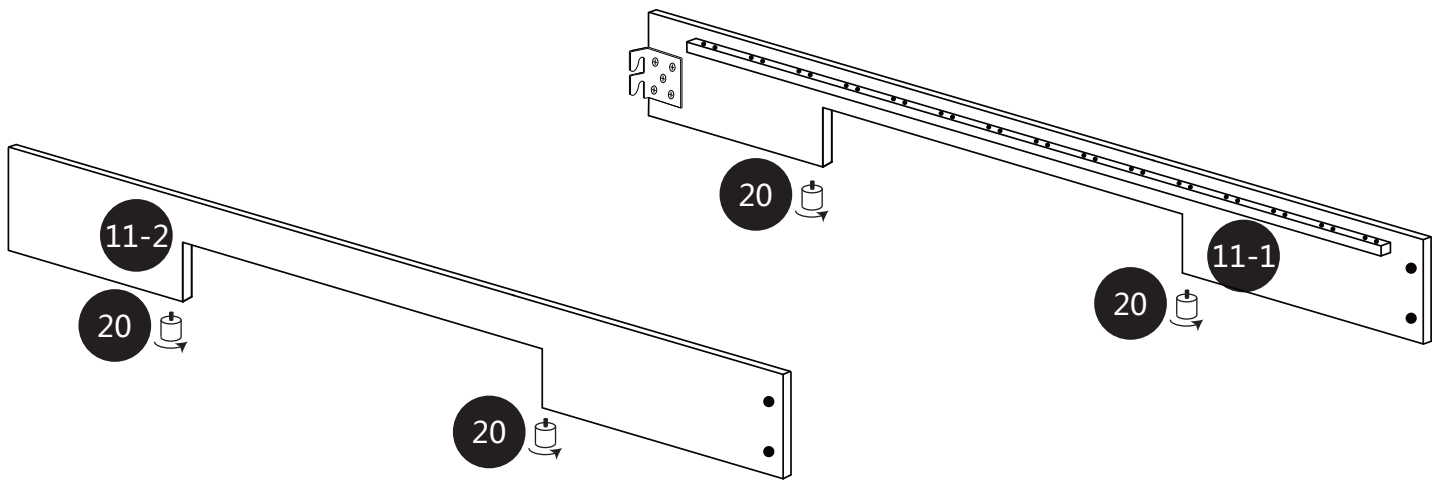

STEP 13

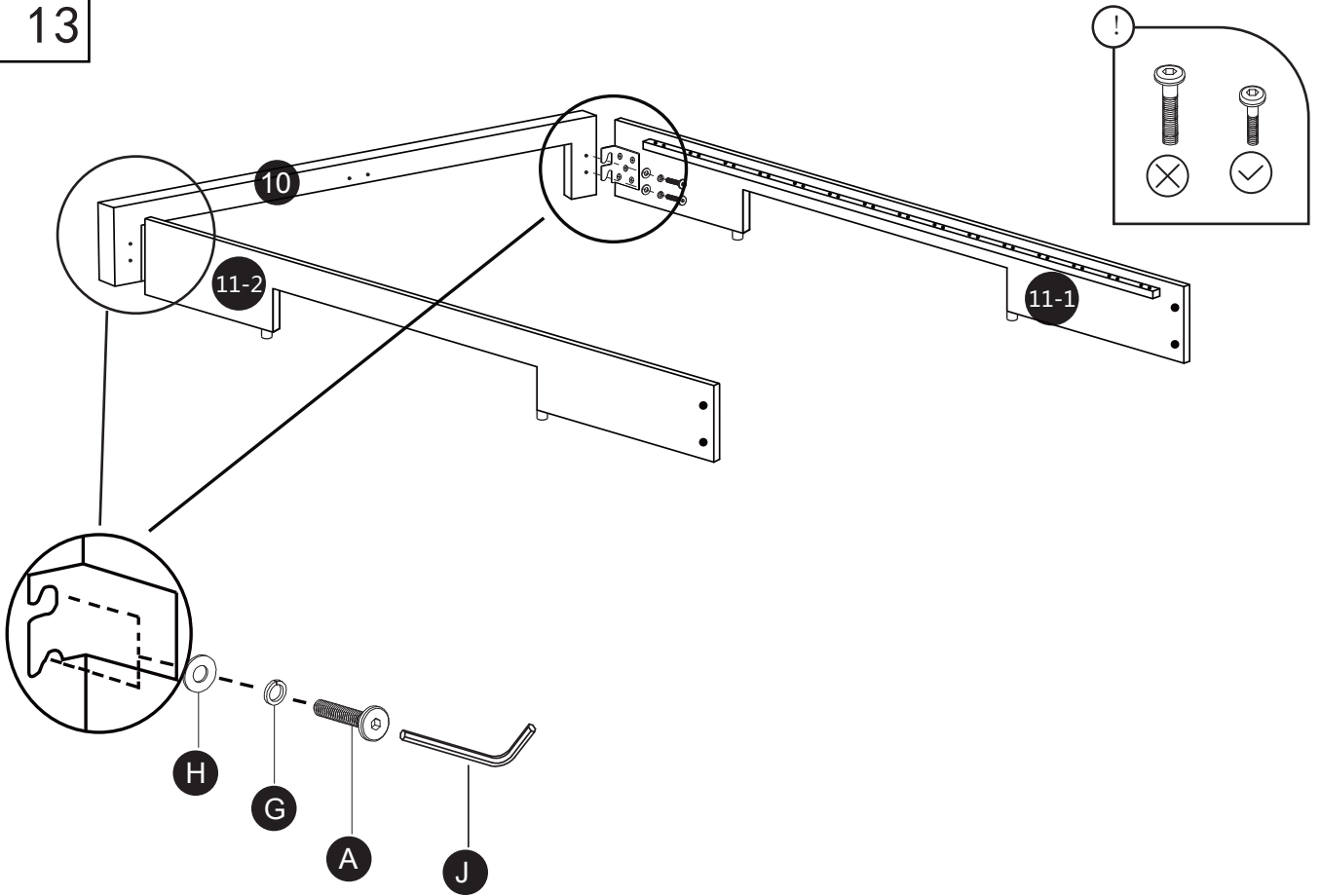

STEP 14

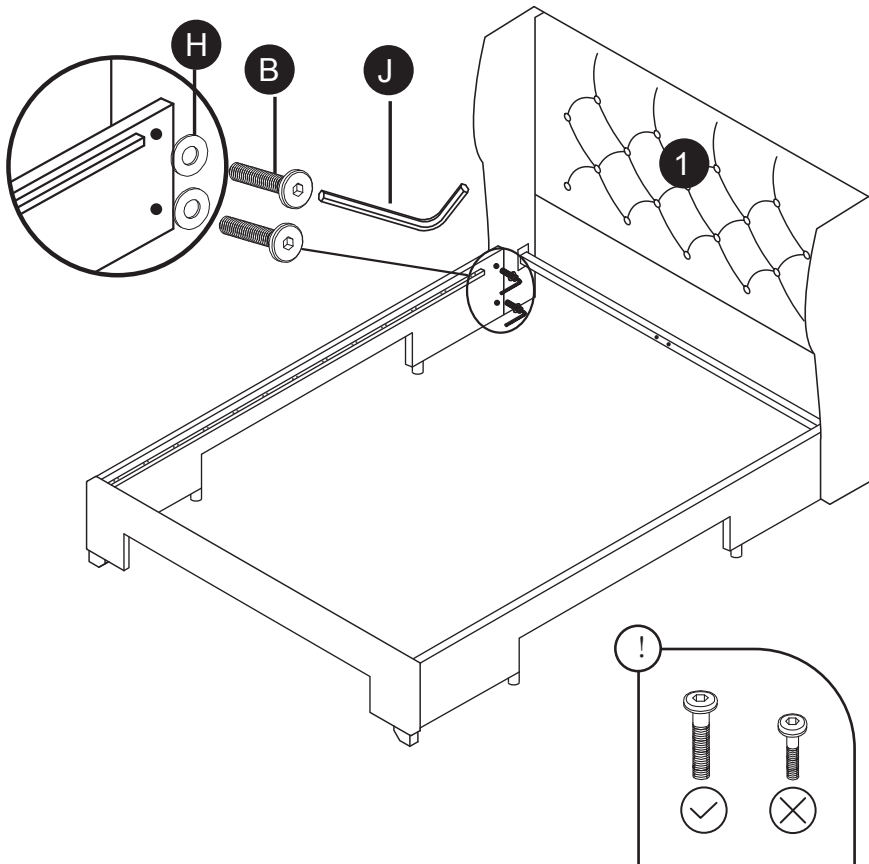

STEP 15

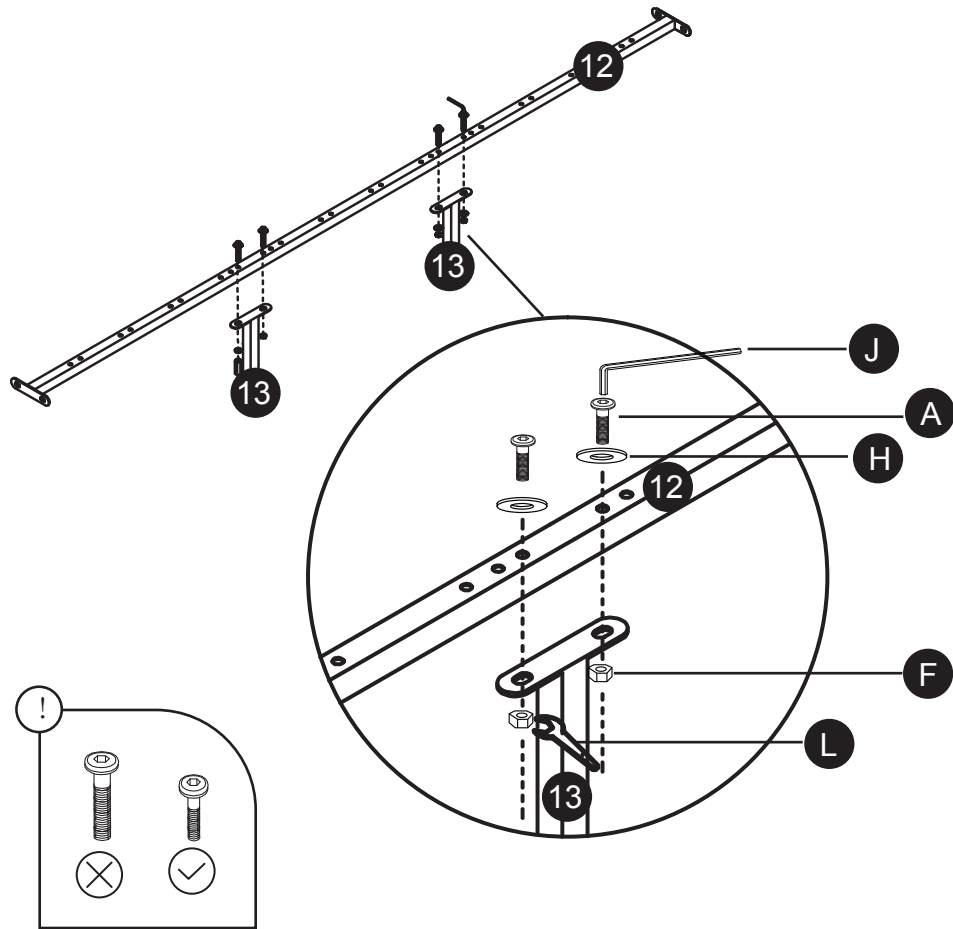

STEP 16

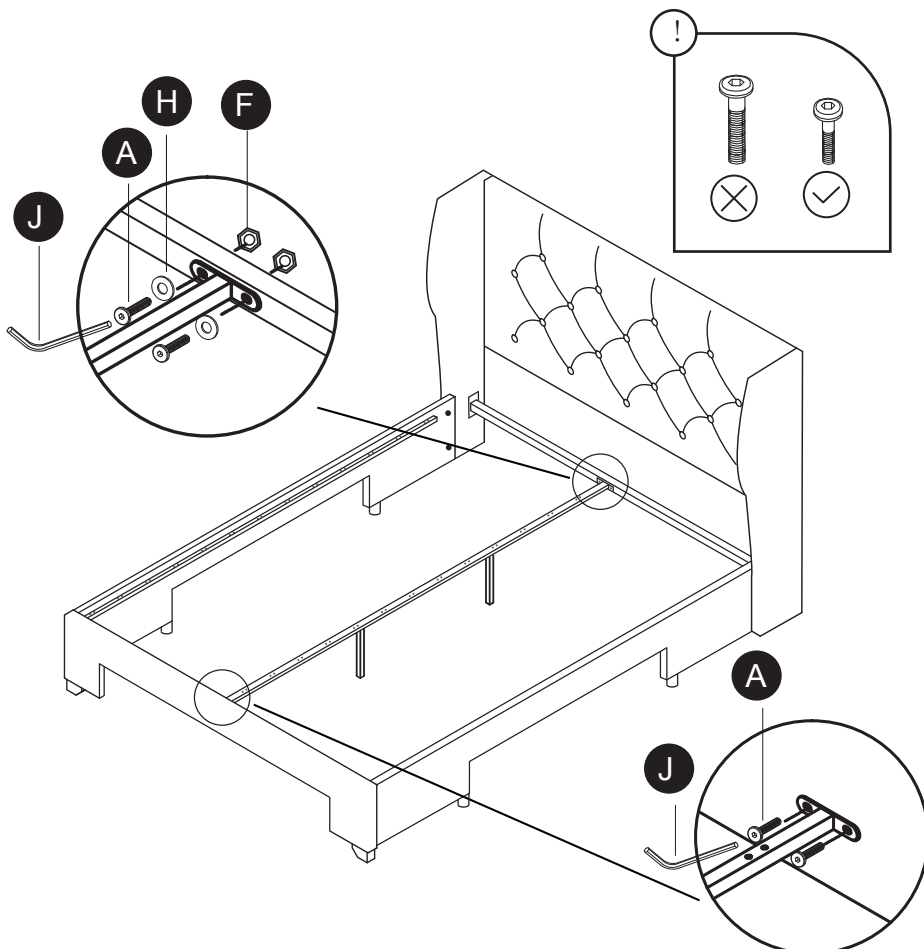

STEP 17

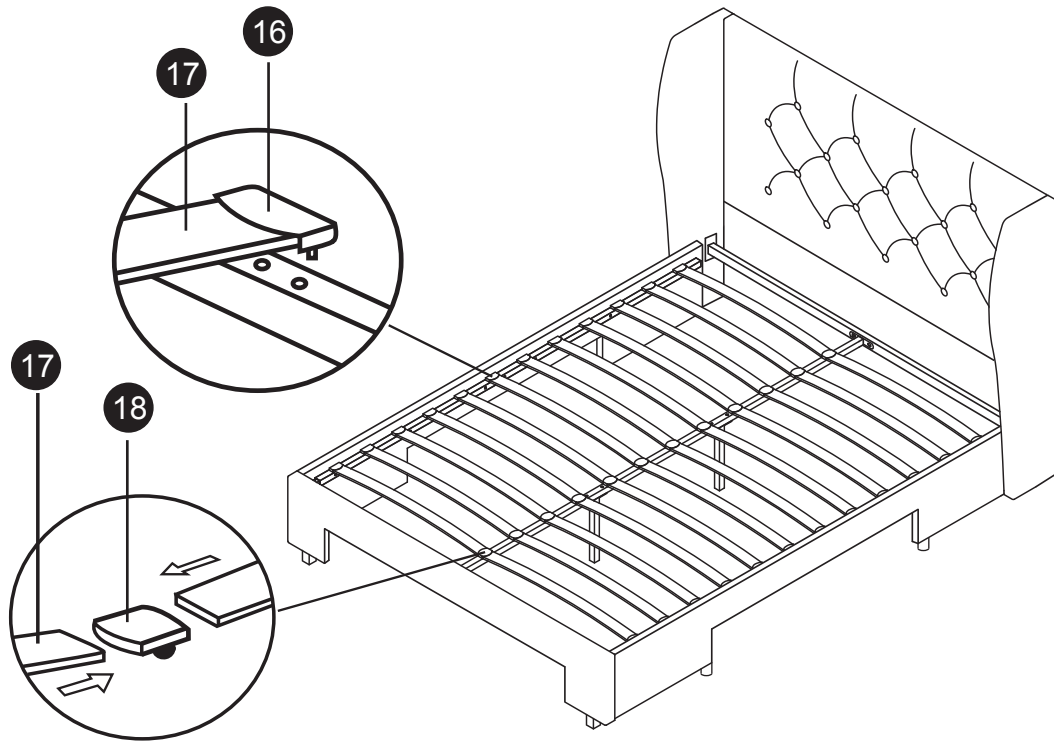

STEP 18

