

EZI GRIP – E-Rack Ramp User Manual

Step 1: Assemble the ramp.

- Use the nuts and bolts provided to fit the two halves of the ramp together.
- Use the wingnut tool provided to tighten the M6 nuts.

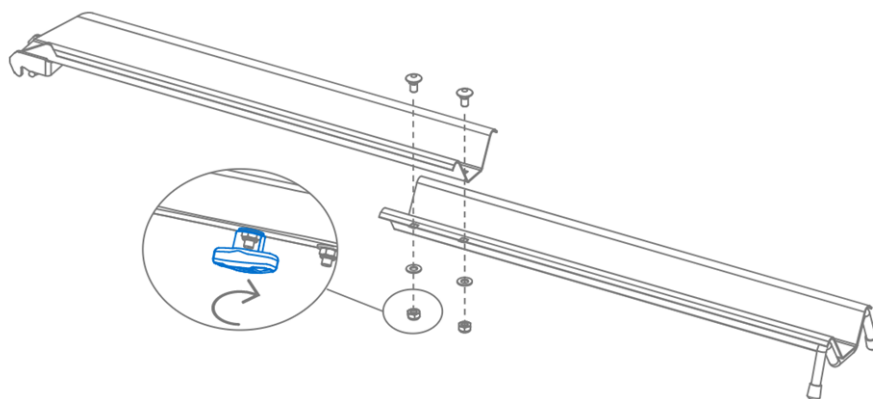

Step 2: Attach the Ramp

- Insert the ramp into the wheel tray of the rack that will support the rear wheel of the bike.
- The ramp slots into position using two shallow hooks at the end of the ramp.
- The rubber feet at the base of the rack should rest on the ground.

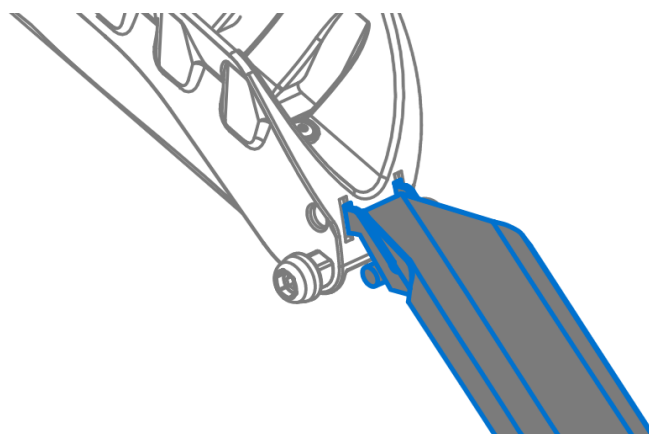

Step 3: Roll the Bike up.... Too EZI

Simply roll the bike up the ramp so the rear wheel of the bike sits in the wheel tray that supports the ramp.

