

Energy Savings You
Can See

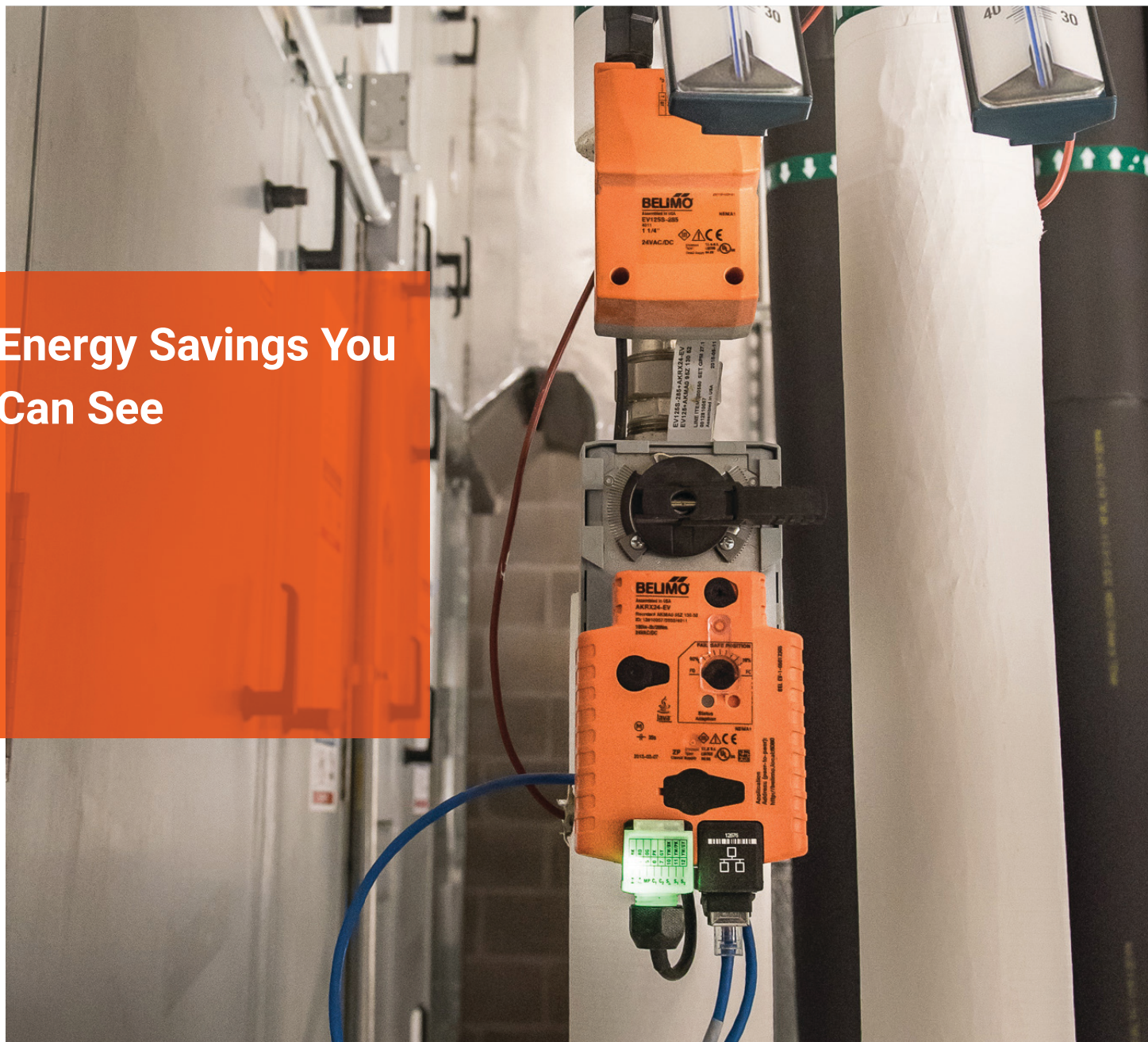

Belimo Energy Valve™ Technical Documentation



Discover the advantages
www.belimo.us

BELIMO

Table of Contents

Component Identification	
3	Small Valve (½" to 2")
3	Large Valve (2½" to 6")
3	Flow Characteristics and Tolerances
4	Features
5	Nomenclature
6	Set Up Options
8	Product Range
9	Control Mode Options
	Installation
10	Piping
10	Installation
10	Handling
11	Remote Sensor Installation
12	Actuator, Temperature, and Flow Sensor Replacement
12	Orientation
12	Insulation
14	Wiring Diagrams
	Control Mode Sequence of Operation
15	Flow Control
15	Power Control
15	Position Control
16	Delta T Manager Options
	Web View
17	Connecting Energy Valve to Ethernet
17	Compatible Browsers
18	Login
18	Web View User Table
19	Overview
19	Data
20	Status
20	Settings
21	Date and Time Settings
21	IP Settings
21	Version Information
22	Data Logging
22	User Administration
22	Maintenance
23	BACnet MP-Slave and Modbus Settings
23	BACnet IP Settings
24	BACnet MS/TP Settings
25	Modbus TCP Settings
25	Modbus RTU Settings
26	Cloud Settings
27	Cloud Connectivity Quick Start Guide
29	Cloud Interface
32	Field Programming and Commissioning Options
33	Web View Settings
36	ZTH US
38	Actuator Adaptation
38	Belimo Data Analysis Tool
39	Downloading Coil Data from Web View
39	Delta T Determination
40	Troubleshooting
	Flow Pressure Characteristics
41	Flow Reduction Chart
41	Input Signal Scaling
42	BACnet Protocol (PICS Statement)
43	BACnet Object Description List
45	Modbus Description
46	Modbus Overview
49	Modbus Registers/Address
52	Warranty
54	Glossary

Overview

Ultrasonic flow meter with temperature and glycol compensation is wet calibrated to obtain published accuracy specifications. The Belimo Energy Valve is now an IoT device with a suite of cloud based services which can benchmark coil performance, analyze glycol concentration, store energy data, send alerts and commission for optimal performance.

The Energy Valve is a pressure independent valve that measures and manages coil energy by using an embedded ultrasonic flow meter, along with supply and return water temperature sensors. The Energy Valve also has the patented Power Control and Belimo Delta T Manager™ logics built-in that monitors coil performance and optimizes the available energy of the coil by maintaining the Delta T. In addition to the standard analog signal and feedback wiring, it communicates its data to the Building Management System (BMS) via BACnet MS/TP or BACnet IP as well as Modbus RTU and Modbus TCP/IP. The built-in web server collects up to 13 months of data that can be downloaded to external tools for further optimization.

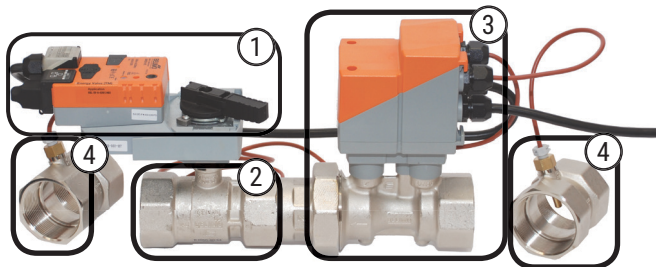
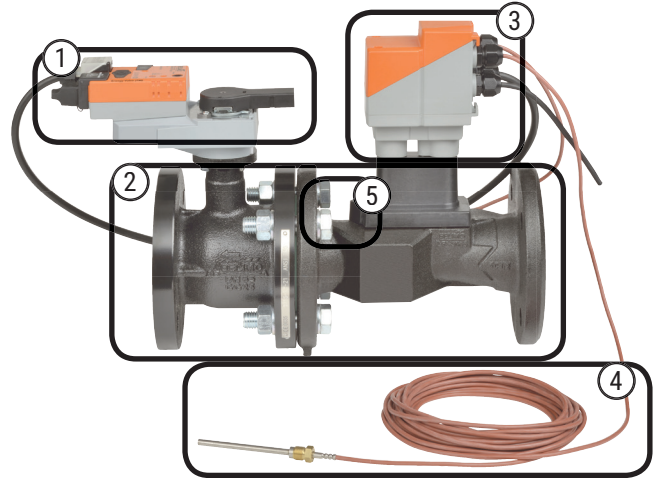

Large Valve (2 ½" - 6")

- ① Non-spring return or electronic fail-safe actuator with analog input and output
- ② 2-way characterized control valve with tight close-off
- ③ Flow sensor: Ultrasonic
- ④ Supply temperature sensor: with thermowell
- ⑤ Return temperature sensor: embedded

Small Valve (½" - 2")

- ① Non-spring return or electronic fail-safe actuator with analog input and output
- ② 2-way characterized control valve with tight close-off 0% leakage
- ③ Ultrasonic flow meter with temperature and glycol compensation is wet calibrated to obtain published accuracy specifications
- ④ Supply and return temperature sensors with thermowells and pipe fittings

Flow Characteristics and Tolerances

Flow Measurement Tolerance $\pm 2\%$ of the actual Flow.

Flow Control Tolerance of the EV: $\pm 5\%$ of the actual Flow.

V'nom = flow rating of valve as listed in catalog

The EV has an equal percentage flow curve.

The equal percentage curve offers a more stable control for heating and cooling applications.

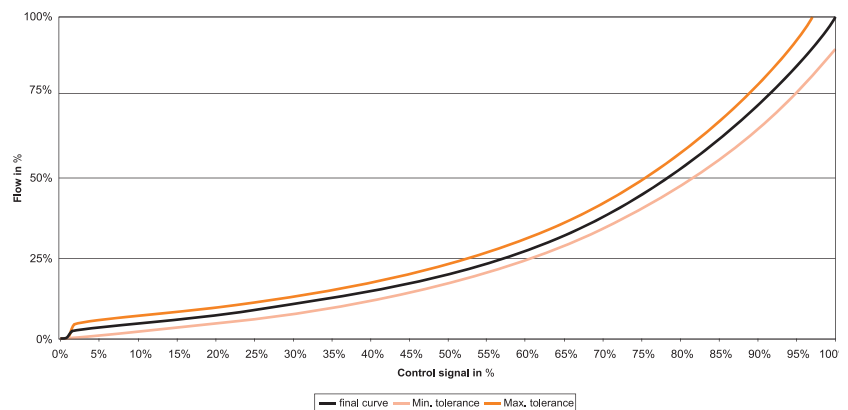

The Energy Valve is an energy metering pressure independent characterized control valve that optimizes, documents and proves water coil performance.

Features

IoT Capability - Advanced System Optimization through cloud technology.

Glycol Monitoring - A feature exclusive to the Energy valve that provides the ability to determine glycol content. By utilizing advanced algorithms in the Belimo designed ultrasonic flow meter the glycol concentration can be provided. A minimum flow rate is provided automatically if glycol content is too low which will prevent system freezing and damage.

Flow Control / Pressure Independent - Accurate and automatic pressure independent flow control is achieved through the Energy Valve's electromagnetic or ultrasonic flow sensor. The valve reacts to changes in pressure and modulates the actuator to maintain the flow setpoint.

Power Control - Allows you to set your heat transfer thermal power output to a maximum full load value with a linear heat transfer response throughout the entire load range. Coil and valve characteristics become irrelevant making the valve pressure and temperature independent.

True Flow - Unlike mechanical pressure independent valves that provide an approximated/calculated flow, the built-in electronic flow meter provides True Flow as feedback. Flow verification is simple, troubleshooting is fast, and True Flow can be shared with the DDC system.

Dynamic Balancing - Coil is always perfectly balanced without the need for any time consuming balancing effort regardless of hydronic pressure variations or piping changes. Occupant comfort is improved by eliminating hunting and cycling of the valve that eliminates overflows and increases equipment longevity.

Energy Meter - Thermal heat transfer energy data is transparent allowing users the ability to see and document system performance during commissioning and over time. Energy waste is identified and eliminated by modifying settings within the Energy Valve logic and by sharing the data with an Energy Management Control System.

Belimo Delta T Manager™ - Continuously monitors the coil ΔT and compares this value with the ΔT setpoint. If the actual ΔT is below the ΔT setpoint, the logic will reduce valve flow to bring ΔT back to the setpoint.

Live Data - Data such as delta T, flow, valve position, and heat transfer thermal power can be viewed live or shared with the DDC system. Commissioning, troubleshooting, and integration to DDC systems is fast and reliable.

Coil History - Live data as well as many other performance parameters are stored for up to 13 months in the actuator. Belimo provides an Excel based Data Analysis Tool that is free to download. This data allows operators to benchmark and better understand system performance.

Characterized Control Valve (CCV) Technology* - High rangeability delivers superior light load flow control, eliminates "opening jump", and on-off control response at low flow. The ball valve is self-cleaning which eliminates debris buildup and clogging.

Zero Leakage / High Close-off* - Wasteful "ghost energy" flow losses are eliminated which saves energy cost and improves occupant comfort.

Low Minimum Pressure Drop - Valve flow output is pressure independent with as low as 1 psid operating differential pressure. Designers can now size valves and pumps to operate at 3 - 4 psid that reduces pump head and allows for smaller pump selection.

Field Configuration - Small hand held tool or web browser users now can make field adjustments. Additional system integration and control with Modbus RTU and TCP/IP proving users with a wide range of options for integration including, BTL listed BACnet MSTP and BACnet IP, Analog and Belimo MP bus, BACnet MS/TP or IP.

Commissioning Report - Provides a report of the valve settings for historical records and operation allowing for a confirmation of valve operation and set up. Save and reload setting: easily save settings from one valve configuration and load in another allowing for fast and accurate integration.

5-Year Warranty - Without cloud integration.

7-Year Warranty - With connection to cloud.**

*Not available on -250 models.

**The following provision supplements the applicable Terms and Conditions of Sale for the Energy Valve 3.0. The 5-year warranty foreseen in the Terms and Conditions of Sale shall be replaced by a 7-year warranty, provided the following conditions are fulfilled:

- The Cloud-connection on the respective BELIMO device is activated
- The respective BELIMO device has been allocated to a Cloud-Account
- At the time of the warranty claim the connection ratio between the BELIMO device and the BELIMO-Cloud is at least 90% (the connection ratio is determined by the amount of hours of Cloud-connection of the BELIMO device divided by its operating hours).

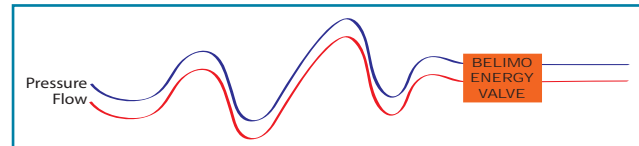

EV	050S	-055		+LRB	24	-EV
Energy Valve	Valve Size	Flow Rate	Pressure Rating	Actuator Type	Power Supply	EV = ½...6"
NPT 2-way (½...2")	050 = ½"	1.65...713 GPM	Blank = ANSI 125	Non Fail-Safe	24 = AC/DC	
Flanged 2-way (2½...6")	075 = ¾"	Refer to valve pages for a full list	-250 = ANSI 250	LRB, LRX	24 V	
	100 = 1"			NRB, NRX		
	125 = 1¼"			ARB, ARX		
	150 = 1½"			GRB, GRX		
	200 = 2"			Electronic Fail-Safe		
	250 = 2½"			AKRB, AKRX		
	300 = 3"			GKRB, GKRX		
	400 = 4"					
	500 = 5"					
	600 = 6"					
	S = Stainless Steel Ball and Stem					
	U = Ultrasonic Flow Sensor with Glycol and Temperature Compensation					

"X" models are customizable.
Refer to page 6 for programming options.

Energy Valve Set Up Options- Default Ordering Example

The Energy Valve can be ordered two different ways once the valve and actuator are selected in the valve section starting on page 5-8.

1. Default. The product is shipped already programmed with the default settings below. The default models use actuators that contain a **B** in the actuator part number i.e. EV050S-055+LR**B**24-EV.
2. Programmed. The product will ship to the specific settings ordered by the customer using the Program Codes in steps 1 through 7 on the next page. The programmed models use actuators that contain an **X** in the actuator part number i.e. EV050S-055+LR**X**24-EV.

NOTE: If no specific settings are selected, the product will ship with the default settings below.

DEFAULT SETTINGS

Maximum Flow	Installation Position	Delta T Manager	Delta T Setpoint	Actuator Setup	Control and Feedback Signal
Maximum flow of the valve	Return	Off	10°F [5.6°C]	Non Fail-Safe Normally Closed (NC)	Control Signal (Y) 2...10 V
				Electronic Fail-Safe Normally Closed (NC) / Fail Closed (FC)	Feedback Signal (U) 2...10 V

COMPLETE DEFAULT ORDERING EXAMPLE:

EV050S-055+LRB24-EV

Energy Valve Set Up Options Programmed Ordering Example



Follow steps 1 through 7.

1. SELECT CODE FOR MAXIMUM FLOW

The maximum GPM can be factory set to the values below. Select the flow code for the desired GPM of the corresponding valve size.

Flow Code	½" GPM	¾" GPM	1" GPM	1¼" GPM	1½" GPM	2" (76.1 GPM)	2" (100 GPM)	2½" GPM	3" GPM	4" GPM	5" GPM	6" GPM
30	1.65	3.1	5.5	8.6	11.9	22.8	30	38	54	95	149	214
37	2	3.8	6.7	10.5	14.7	28.2	37	47	67	117	183	264
45	2.5	4.6	8.2	12.8	17.8	34.2	45	57	81	143	223	321
55	3	5.7	10	15.7	21.8	41.9	55	70	99	174	272	392
63	3.5	6.5	11.5	18	24.9	47.9	63	80	113	200	312	449
65	3.6	6.7	11.8	18.5	25.7	49.5	65	83	117	206	322	463
68	3.7	7	12.4	19.4	26.9	51.7	68	86	122	216	337	485
71	3.9	7.3	12.9	20.2	28.1	54	71	90	128	225	351	506
72	4	7.4	13.1	20.5	28.5	54.8	72	91	130	228	356	513
75	4.1	7.7	13.7	21.4	29.7	57.1	75	95	135	238	371	535
76	4.2	7.8	13.8	21.7	30.1	57.8	76	97	137	241	376	542
78	4.3	8	14.2	22.2	30.9	59.4	78	99	140	247	386	556
80	4.4	8.2	14.6	22.8	31.7	60.9	80	102	144	254	396	570
82	4.5	8.4	14.9	23.4	32.5	62.4	82	104	148	260	406	585
83	4.6	8.5	15.1	23.7	32.9	63.2	83	105	149	263	411	592
85	4.7	8.8	15.5	24.2	33.7	64.7	85	108	153	269	421	606
87	4.8	9	15.8	24.8	34.5	66.2	87	110	157	276	431	620
89	4.9	9.2	16.2	25.4	35.2	67.7	89	113	160	282	441	635
91	5	9.4	16.6	25.9	36	69.3	91	116	164	288	450	649
93	5.1	9.6	16.9	26.5	36.8	70.8	93	118	167	295	460	663
95	5.2	9.8	17.3	27.1	37.6	72.3	95	121	171	301	470	677
97	5.3	10	17.7	27.6	38.4	73.8	97	123	175	307	480	692
00	5.5	10.3	18.2	28.5	39.6	76.1	100	127	180	317	495	713

2. SELECT CODE FOR INSTALLATION POSITION

Where the Energy Valve is installed in a system either on the supply or return.

Code	Description
A	Supply
Z	Return

3. SELECT CODE FOR DELTA T MANAGER STATUS

The Delta T Manager provides a fixed Delta T setpoint.
Delta T Scaling varies the setpoint.

Code	Description
0	OFF
1	ON Delta T Manager
2	ON Delta T Scaling

4. SELECT CODE FOR DELTA T SETPOINT

This is the Delta T limit of the coil

Code	Description	Code	Description	Code	Description	Code	Description	Code	Description	Code	Description	Code	Description
02	02°F / 1.1°C/K	17	17°F / 9.4°C/K	32	32°F / 17.8°C/K	47	47°F / 26.1°C/K	62	62°F / 34.4°C/K	77	77°F / 42.7°C/K	92	92°F / 51.1°C/K
03	03°F / 1.7°C/K	18	18°F / 10.0°C/K	33	33°F / 18.3°C/K	48	48°F / 26.7°C/K	63	63°F / 35.0°C/K	78	78°F / 43.3°C/K	93	93°F / 51.6°C/K
04	04°F / 2.2°C/K	19	19°F / 10.6°C/K	34	34°F / 18.9°C/K	49	49°F / 27.2°C/K	64	64°F / 35.5°C/K	79	79°F / 43.8°C/K	94	94°F / 52.2°C/K
05	05°F / 2.8°C/K	20	20°F / 11.1°C/K	35	35°F / 19.4°C/K	50	50°F / 27.8°C/K	65	65°F / 36.1°C/K	80	80°F / 44.4°C/K	95	95°F / 52.7°C/K
06	06°F / 3.3°C/K	21	21°F / 11.7°C/K	36	36°F / 20.0°C/K	51	51°F / 28.3°C/K	66	66°F / 36.6°C/K	81	81°F / 45.0°C/K	96	96°F / 53.3°C/K
07	07°F / 3.9°C/K	22	22°F / 12.2°C/K	37	37°F / 20.6°C/K	52	52°F / 28.9°C/K	67	67°F / 37.2°C/K	82	82°F / 45.5°C/K	97	97°F / 53.8°C/K
08	08°F / 4.4°C/K	23	23°F / 12.8°C/K	38	38°F / 21.1°C/K	53	53°F / 29.4°C/K	68	68°F / 37.7°C/K	83	83°F / 46.1°C/K	98	98°F / 54.4°C/K
09	09°F / 5.0°C/K	24	24°F / 13.3°C/K	39	39°F / 21.7°C/K	54	54°F / 30.0°C/K	69	69°F / 38.3°C/K	84	84°F / 46.6°C/K	99	99°F / 55.0°C/K
10	10°F / 5.6°C/K	25	25°F / 13.9°C/K	40	40°F / 22.2°C/K	55	55°F / 30.6°C/K	70	70°F / 38.8°C/K	85	85°F / 47.2°C/K	100	100°F / 55.5°C/K
11	11°F / 6.1°C/K	26	26°F / 14.4°C/K	41	41°F / 22.8°C/K	56	56°F / 31.1°C/K	71	71°F / 39.4°C/K	86	86°F / 47.7°C/K		
12	12°F / 6.7°C/K	27	27°F / 15.0°C/K	42	42°F / 23.3°C/K	57	57°F / 31.7°C/K	72	72°F / 40.0°C/K	87	87°F / 48.3°C/K		
13	13°F / 7.2°C/K	28	28°F / 15.6°C/K	43	43°F / 23.9°C/K	58	58°F / 32.2°C/K	73	73°F / 40.5°C/K	88	88°F / 48.8°C/K		
14	14°F / 7.8°C/K	29	29°F / 16.1°C/K	44	44°F / 24.4°C/K	59	59°F / 32.8°C/K	74	74°F / 41.1°C/K	89	89°F / 49.4°C/K		
15	15°F / 8.3°C/K	30	30°F / 16.7°C/K	45	45°F / 25.0°C/K	60	60°F / 33.3°C/K	75	75°F / 41.6°C/K	90	90°F / 50.0°C/K		
16	16°F / 8.9°C/K	31	31°F / 17.2°C/K	46	46°F / 25.6°C/K	61	61°F / 33.8°C/K	76	76°F / 42.2°C/K	91	91°F / 50.5°C/K		

5. SELECT CODE FOR ACTUATOR SETUP

NON FAIL-SAFE

Code	Description
1	NO
2	NC

ELECTRONIC FAIL-SAFE

Code	Description
3	NO/FO
4	NO/FC
5	NC/FO
6	NC/FC

6. SELECT CODE FOR CONTROL AND FEEDBACK SIGNAL

Code	Description
0	Control Signal (Y) 0.5...10 V
	Feedback Signal (U) 0.5...10V
2	Control Signal (Y) 2...10 V
	Feedback Signal (U) 2...10 V

This section does not affect BACnet or Modbus functions.

7. DOES THE ORDER REQUIRE TAGGING?

Part number for tagging: 99981-00101
 Valves may be tagged per customer specification. (\$12.00 charge per tag)
 Example: AHU-1
 FCU-2

Part Number for tagging:
 99981-00101

COMPLETE PROGRAMMED ORDERING EXAMPLE

EV050S-055+LRX24-EV(00, Z, 0, 10, 2, 2)

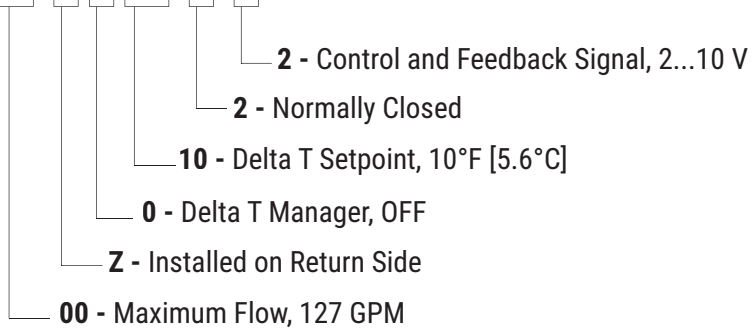

Energy Valve Product Range

	GPM Range	Valve Nominal Size		Type	Suitable Actuators	
		Inches	DN [mm]		2-way	Non Fail-Safe
NPT	1.65...5.5*	½	15	EV050S-055	LRB(X)24-EV	AKRB(X)24-EV
	3.1...10.3*	¾	20	EV075S-103		
	5.5...18.2*	1	25	EV100S-182		
	8.6...28.5*	1¼	32	EV125S-285	NRB(X)24-EV	
	11.9...39.6*	1½	40	EV150S-396	ARB(X)24-EV	
	22.8...76.1*	2	50	EV200S-761		
	30...100*	2	50	EV200S-1000**		
Flanged ANSI 125	38...127*	2½	65	EV250SU-127	ARB(X)24-EV	GKRB(X)24-EV
	54...180*	3	80	EV300SU-180		
	95...317*	4	100	EV400SU-317	GRB(X)24-EV	
	149...495*	5	125	EV500SU-495		
	214...713*	6	150	EV600SU-713		
Flanged ANSI 250	38...127*	2½	65	EV250SU-127-250	ARB(X)24-EV	AKRB(X)24-EV
	54...180*	3	80	EV300SU-180-250		
	95...317*	4	100	EV400SU-317-250	GRB(X)24-EV	GKRB(X)24-EV
	149...495*	5	125	EV500SU-495-250		
	214...713*	6	150	EV600SU-713-250		

*V_{nom} = Maximum flow for each valve body size.
 ** Fluid temperature range is 39...250°F [4...120°C]

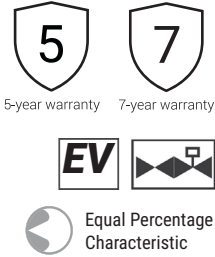
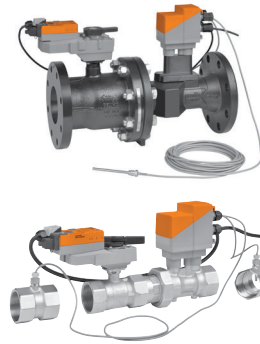

Mode of Operation

The Energy Valve is an energy metering pressure independent control valve that optimizes, documents, and proves water coil performance.

Product Features

Measures Energy: using its built-in electronic flow sensor and supply and return temperature sensors.

Controls Power: with its Power Control logic, providing linear heat transfer regardless of temperature and pressure variations.

Manages Delta T: by solving Low Delta T Syndrome. In addition, it reduces pumping costs while increasing chiller/boiler efficiency by optimizing coil efficiency.

Actuator Specifications

Control type	modulating
Manual override	LR, NR, AR, GR, AKR, GKR
Electrical connection	3 ft. [1 m] cable with ½" conduit fitting

Valve Specifications

Fluid	chilled or hot water, 60% glycol max
Flow characteristic	equal percentage/linear
Sizes	½", ¾", 1", 1¼", 1½", 2", 2½", 3", 4", 5", 6"
End fitting	NPT female (½"...2") pattern to mate with ANSI 125 or 250 flange (2½"...6")

Materials

Body	
Valve	forged brass, nickel plated (½"...2") cast iron - GG25 (2½"...6")
Sensor housing	forged brass, nickel plated (½"...2") ductile iron - GGG50 (2½"...6")
Ball	stainless steel
Stem	stainless steel
Characterizing disc	Tefzel® (½"...2") stainless steel (2½"...6")

Fluid temp range	14...250°F [-10...+120°C], 39...250°F [4...120°C] (EV200SU-1000)
------------------	---

Body pressure rating	360 psi (½"...2"), ANSI 125, Class B (2½"...6") ANSI 250 (2½"...6")
----------------------	--

Close-off pressure	200 psid (½"...2"), 100 psid (ANSI 125, 2½"...6"), 310 psid (ANSI 250, 2 ½" ...6")
--------------------	---

Differential pressure range (ΔP)	see technical documentation
----------------------------------	-----------------------------

Leakage	0%
---------	----

Communication	BACnet IP, BACnet MS/TP, listed by BTL, web server, Modbus RTU/IP, Belimo MP-Bus, analog
---------------	--

Remote temperature sensor length

½"...2"	2 ft. 7.5 in. [0.8 m] short, 9.8 ft. [3 m] long
2½"...6"	32.8 ft. [10 m]

SET-UP - Specify Upon Ordering

2-WAY VALVE

NON FAIL-SAFE STAYS IN LAST POSITION	<p>LRX...Series NRX...Series ARX...Series GRX...Series</p>	<p>NC: Normally Closed- valve will open as voltage increases.</p>	<p>NO: Normally Open- valve will close as voltage increases.</p>		
	ELECTRONIC FAIL-SAFE STAYS IN FAIL-SAFE POSITION	<p>AKRX...Series GKRX...Series</p>	<p>NO/FO Valve: Normally Open- valve will close as voltage increases. Fail Action: Will fail open upon power loss.</p>	<p>NO/FC Valve: Normally Open- valve will close as voltage increases. Fail Action: Will fail closed upon power loss.</p>	<p>NC/FO Valve: Normally Closed- valve will open as voltage increases. Fail Action: Will fail open upon power loss.</p>

FUNCTIONALITY

The Energy Valve offers different operating modes which can be selected using the Web View or ZTH US.

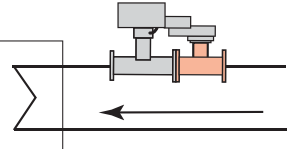
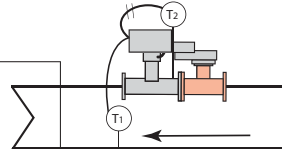
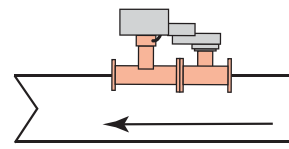
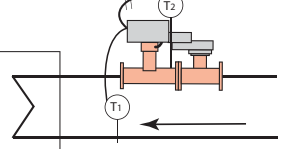
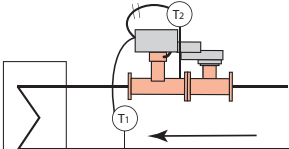
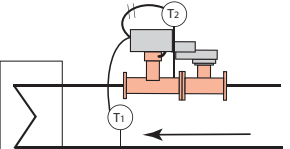
	Delta T Manager OFF	Delta T Manager ON
Position Control	 <p>Position Control The Energy Valve works as a normal pressure dependent valve. The actuator is positioned based on the DDC control signal.</p> <p>Y Signal controls the valve position.</p>	 <p>Position Control + Delta T Manager The Energy Valve works as a pressure dependent valve. If the measured ΔT is lower than the ΔT setpoint the flow will be reduced by the Delta T Manager logic to achieve the setpoint, regardless of the control signal Y.</p> <p>Note: In position control, only ΔT Manager can be selected, ΔT Manager Scaling will not be available.</p> <p>Y Signal controls the valve position as long as the ΔT is above the ΔT setpoint.</p>
Flow Control	 <p>Pressure Independent Flow Control The Energy Valve works as an ePIV (Electronic Pressure Independent Valve). The valve reacts to any change in pressure and modulates the actuator to maintain the flow setpoint based on the DDC control signal.</p> <p>Y Signal controls the flow.</p>	 <p>Pressure Independent Flow Control+ Delta T Manager The Energy Valve works as an ePIV. However, if the measured ΔT is lower than the ΔT setpoint, the flow will be reduced by the Delta T Manager logic to achieve the ΔT setpoint, regardless of the control signal Y.</p> <p>Y Signal controls the flow as long as the ΔT is above the ΔT setpoint.</p>
Power Control	 <p>Power Control The Energy Valve adjusts flow to maintain the thermal power setpoint. If the measured coil power is below setpoint, flow will be increased. If the measured coil power is above setpoint, flow will be decreased as long as the defined V'max is not exceeded.</p> <p>Y Signal controls the coil thermal power setpoint (BTU/hr or kW).</p>	 <p>Power Control + Delta T Manager The Energy Valve adjusts flow to maintain the thermal power setpoint. If the measured coil power is below setpoint, flow will be increased. If the measured coil power is above setpoint, flow will be decreased as long as the defined V'max is not exceeded. If the measured ΔT is lower than the ΔT setpoint, flow will be reduced by the Delta T Manager logic and will override the thermal power control setpoint.</p> <p>Y Signal controls the thermal power setpoint as long as the ΔT is above the ΔT setpoint.</p>

Tech.Doc - 06/20 - Subject to change. © Belimo Aircontrols (USA), Inc.

Piping

The Energy Valve is recommended to be installed on the return side of the coil. This diagram illustrates a typical application. Consult engineering specification and drawings for particular circumstances.

For 2½" through 6" valves, install the provided thermowell on the other side of the coil (T1). For ½" through 2" valves, both temperature sensors are remote and are supplied with female NPT threaded pipe body. The (T2) sensor should be installed downstream in the direction of flow after the valve assembly. The (T1) sensor should be installed on the other side of the coil.

Belimo recommends installing one strainer per system. If the system has multiple branches, it is recommended to install one strainer per branch.

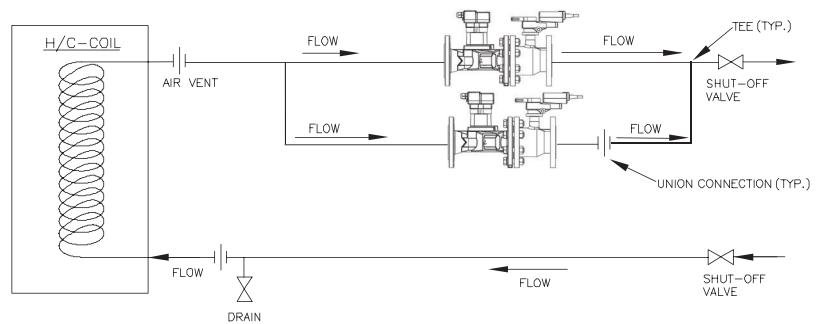
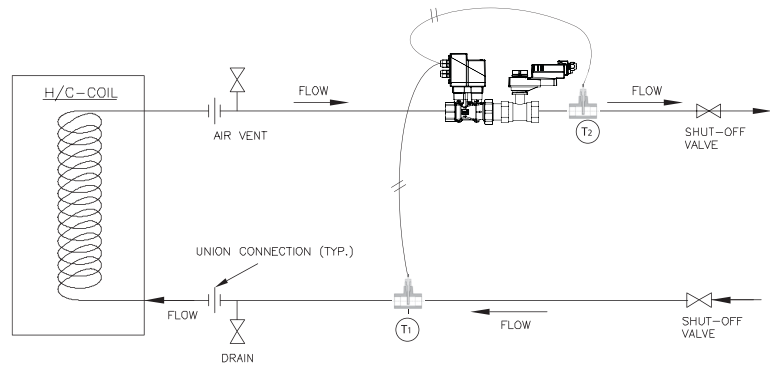

Installation

Inlet Length

The Energy Valve requires a section of straight pipe on the valve inlet to achieve the flow accuracy specified. This section should be at least 5 pipe diameters long with respect to the size of the valve.

- ½" [DN15] 5 x nominal pipe size = 2.5" [64 mm]
- ¾" [DN20] 5 x nominal pipe size = 3.75" [95 mm]
- 1" [DN25] 5 x nominal pipe size = 5" [127 mm]
- 1¼" [DN32] 5 x nominal pipe size = 6.25" [159 mm]
- 1½" [DN40] 5 x nominal pipe size = 7.5" [191 mm]
- 2" [DN50] 5 x nominal pipe size = 10" [254 mm]

- 2½" [DN65] 5 x nominal pipe size = 12.5" [317 mm]
- 3" [DN80] 5 x nominal pipe size = 15" [381 mm]
- 4" [DN100] 5 x nominal pipe size = 20" [508 mm]
- 5" [DN125] 5 x nominal pipe size = 25" [635 mm]
- 6" [DN150] 5 x nominal pipe size = 30" [762 mm]

Outlet Length

No requirements for outlet length.
Elbows can be installed directly after the valve.

Handling

Lift the Energy Valve from the valve body. Do not lift this product by the actuator. Lifting the product by the actuator can break the linkage and void the warranty.

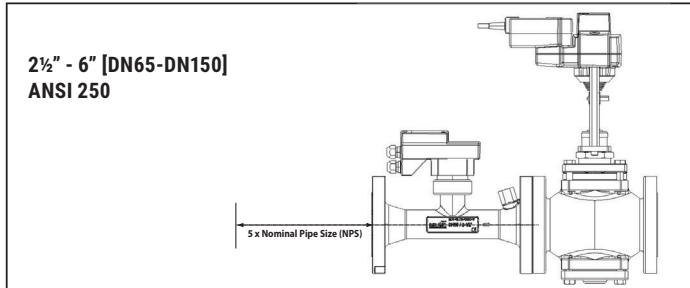
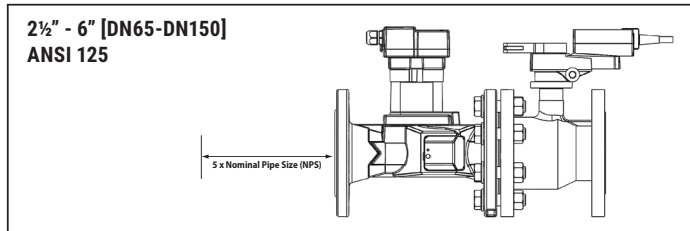
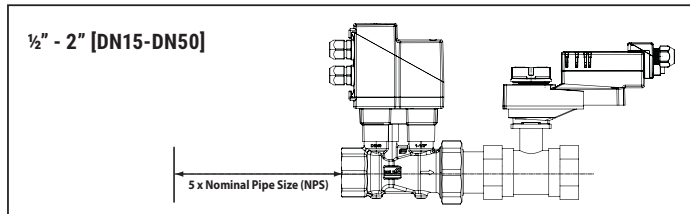

Remote Sensor Installation:

½" [DN 15] to 2" [DN 50]

Two remote sensors with female NPT pipe bodies are provided with the Energy Valve and must be installed on opposite sides of the coil. Temperature Sensor 1 (T1) is equipped with a longer sensor cable than Temperature Sensor 2 (T2). It is recommended that the Energy Valve is installed on the return side of the coil. The T1 sensor will be on the supply side and the T2 sensor will be on the return. The T2 sensor should be installed upstream in the direction of the flow after the valve.

Female NPT Dimensions

IN	DN [mm]	A	B	C	D	E
½	15	½" NPT	0.6"	2.06"	0.62"	0.76"
¾	20	¾" NPT	0.65"	2.24"	0.82"	0.63"
1	25	1" NPT	0.76"	2.54"	1.02"	0.53"
1¼	32	1¼" NPT	0.85"	2.77"	1.29"	1.61"
1½	40	1½" NPT	0.87"	2.77"	1.61"	1.77"
2	50	2" NPT	1.04"	3.16"	2.00"	2.00"

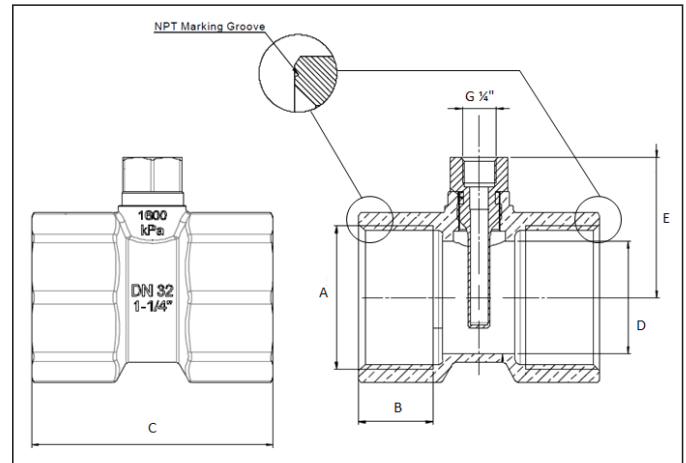

2½" [DN 65] to 6" [DN 150]

A thermowell is provided with the remote temperature sensor. The well should be installed on the pipe prior to installing the remote temperature sensor. The remote temperature sensor should be installed on the opposite pipe entering the coil from where the Energy Valve is installed. A ½" NPT female union should be welded on the pipe to allow the installation of the thermowell. The Energy Valve is equipped with a 32 ft. [10 m] cable for the remote sensor. If a shorter remote sensor cable is required, the cable is also available in the following sizes: 4.9 ft. [1.5 m], 9.8 ft. [3 m], or 16.4 ft. [5 m]. Order the appropriate size for the application.

Note: If a different sensor with a different cable length has been installed, the change must be applied to the Energy Valve Web View Settings. Refer to Web View Settings table on page 33.

Do not cut sensor cables, this will produce inaccurate data. Belimo offers different sensor cabling lengths options.

Remote Well Installation Dimensional Parameters

IN	DN [mm]	EL	ET	L max.
2 ½	65	3.66" [93]	2.36" [60]	1.18" [30]
3	80	3.66" [93]	2.36" [60]	1.18" [30]
4	100	3.66" [93]	2.36" [60]	1.18" [30]
5	125	3.66" [93]	2.36" [60]	1.18" [30]
6	150	3.66" [93]	2.36" [60]	1.18" [30]

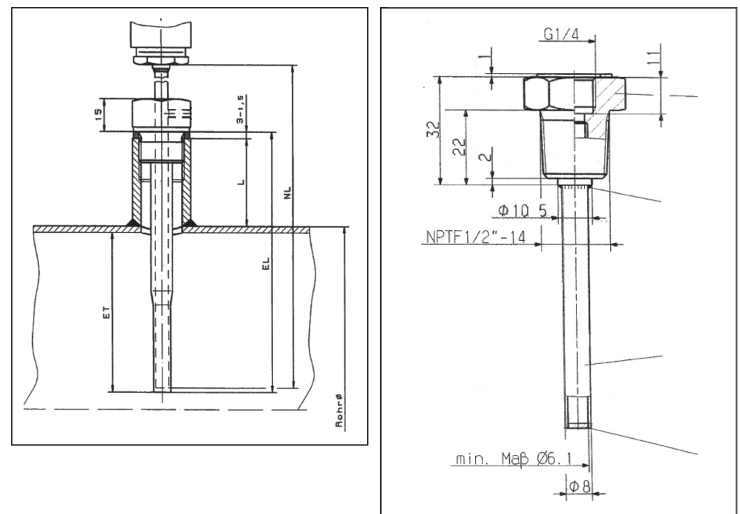

Actuator, Temperature & Flow Sensor Replacement

The actuator, temperature sensors, and the flow sensor can be removed from the valve, if needed. Actuator and flow sensor must be replaced together. Either temperature sensor can be removed without draining the system; each temperature sensor is inserted in a thermowell.

½" to 2" Energy Valves

The flow sensor is part of the flow unit. The flow unit consists of the ultrasonic flow sensor and housing. The flow sensor cannot be separated from its flow housing. To separate the flow unit from the valve assembly, unthread the coupler/union that connects the flow housing to the control valve assembly. Note: The coupler thread is a straight pipe thread.



2½" to 6" Energy Valves (Electromagnetic)

The flow sensor can be separated from its flow housing. To remove the flow sensor from the housing, loosen the threaded plastic locking nut. To assemble, ensure the O-ring and flange locking ring are in place. Hand tighten the threaded plastic locking nut. Note: The flanged sensor housing and flanged valve bodies do not need to be disassembled.



2½" to 6" Energy Valves (Ultrasonic)

The flow sensor is part of the flow unit. The flow unit consists of the ultrasonic flow sensor and housing. The flow sensor cannot be separated from its flow housing. To separate the flow unit from the valve assembly, unbolt the flange that connects the flow housing to the control valve assembly.

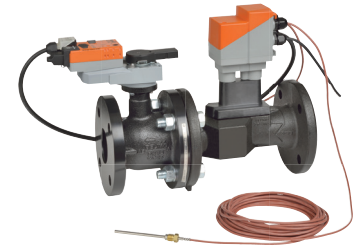

IMPORTANT: The flow sensor is directly embedded in the flow housing. Before removing the flow sensor, the system must be relieved of pressure, drained and or closed directly upstream and downstream of the valve to circumvent any system leakage. The valve must not be lifted from the flow sensor or actuator. Disassembly and or lifting by the actuator or flow sensor will damage the assembly and void warranty.

Note: If a different sensor with a different cable length has been installed, the change must be applied to the Energy Valve Web View Settings. Refer to Web View Settings table on page 33.

Do not cut sensor cables, this will produce inaccurate data. Belimo offers different sensor cabling lengths options.

Orientation

Energy Valve shall be installed with flow in the direction of the arrow on the valve body.

The valve assembly can be installed in a vertical or horizontal arrangement, as long as the actuator is positioned to avoid condensation from dripping onto the actuator.

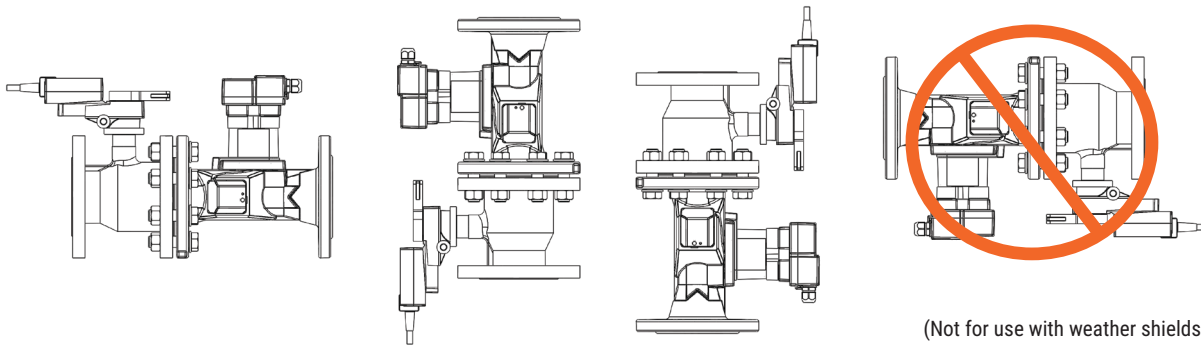

(Not for use with weather shields)

Insulation

The insulation should be below the actuator.

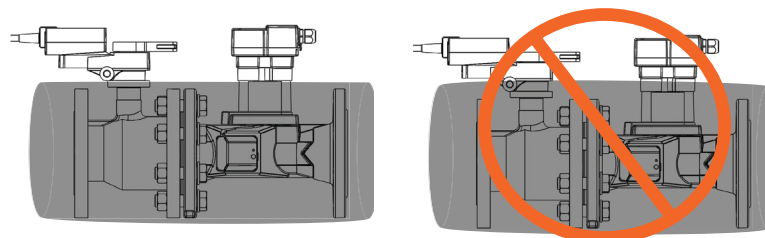

Installation

1. Inspect shipping package, valve, linkage, and actuator for physical damage. If shipping damage has occurred, notify appropriate carrier. Do not install.
2. If a replacement, remove existing valve, linkage and actuator from the piping system.
3. If actuator and linkage are removed, they must be reinstalled correctly. The actuator must be rotated so that the valve seats properly close off.
4. Install valve with the proper ports as inlets and outlets. Check that inlet and outlet of 2-way valves are correct. Flow direction arrows must be correct.
5. Blow out all piping and thoroughly clean before valve installation.
6. Clean flanges with wire brush and rag. Clean pipes, flanges, and valve flanges before installation; check for any foreign material that can become lodged in trim components. Strainers should be cleaned after initial startup.
7. Valve must be installed with the stem towards the vertical, not below horizontal. See Orientation on page 12.
8. These valves are designed to be installed between ANSI Class 125/150 flanges only.
9. -250 models are designed to be installed between ANSI Class 250/300 flanges only.
10. Carefully follow installation using ANSI piping practices.

Valve should not be used for combustible gas applications. Gas leaks

and explosions may result.

Do not install in systems, which exceed the ratings of the valve.

- Avoid installations where valve may be exposed to excessive moisture, corrosive fumes, vibration, high ambient temperatures, elements, or high traffic areas with potential for mechanical damage.
- Valve assembly location must be within ambient ratings of actuator. If temperature is below -22°F, a heater is required.
- Valve assembly will require heat shielding, thermal isolation, or cooling if combined effect of medium and ambient temperatures – conduction, convection, and radiation – is above 122°F for prolonged periods at the actuator.
- Visual access must be provided. Assembly must be accessible for routine schedule service. Contractor should provide unions for removal from line and isolation valves.
- Avoid excessive stresses. Mechanical support must be provided where reducers have been used and the piping system may have less structural integrity than full pipe sizes.
- Sufficient upstream piping runs must be provided to ensure proper valve capacity and flow response. See installation section for details.
- Life span of valve stems and O-rings is dependent on maintaining non-damaging conditions. Poor water treatment or filtration, corrosion, scale, other particulate can result in damage to trim components. A water treatment specialist should be consulted.
- It is not necessary to install one strainer per unit. Belimo recommends installing one strainer per system. If the system has multiple branches, it is recommended to install one strainer per branch.

Wiring Diagrams

✂️ INSTALLATION NOTES

- Ⓐ Actuators with appliance cables are numbered.
- ⚠️ **CAUTION Equipment damage!**
Actuators may be connected in parallel.
Power consumption and input impedance must be observed.
- ⚡️ Actuators may also be powered by 24 VDC.
- ⚡️ A 500 Ω resistor converts the 4 to 20 mA control signal to 2 to 10 VDC.
- ⚠️ Actuators with plenum rated cable do not have numbers on wires; use color codes instead.

📄 APPLICATION NOTES

- ◆ Meets cULus requirements without the need of an electrical ground connection

⚠️ **WARNING Live Electrical Components!**
During installation, testing, servicing and troubleshooting of this product, it may be necessary to work with live electrical components. Have a qualified licensed electrician or other individual who has been properly trained in handling live electrical components perform these tasks. Failure to follow all electrical safety precautions when exposed to live electrical components could result in death or serious injury.

NOTE: BACnet set point writing will deactivate Analog Signal input.
Valve power must be cycled to reactivate its response to analog signal.

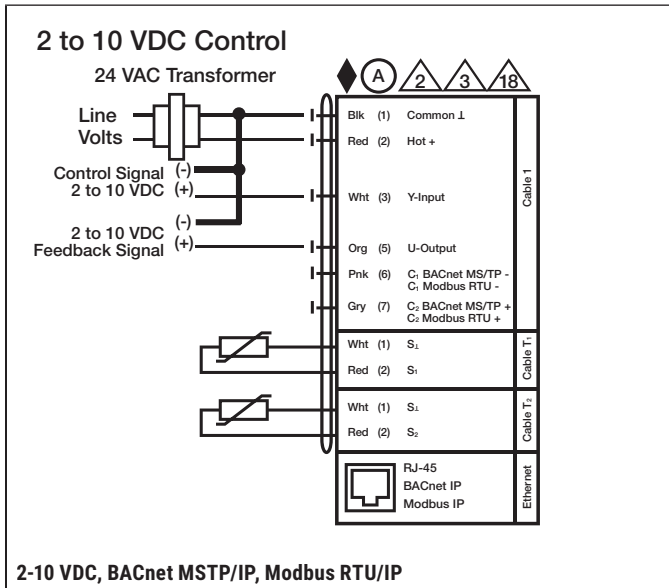
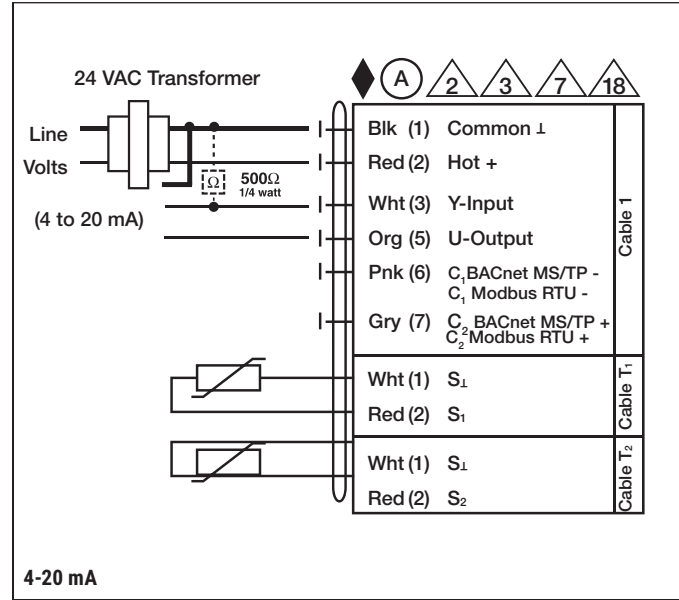

System Ground

In cases where the valve body is electrically isolated from the water pipe, an earth ground should be installed in order for the sensor to work properly. Earth ground can be connected directly on the sensor body. A connection point is provided on the flange of the sensor body.

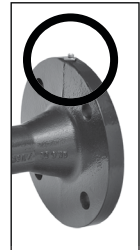

Flow Control

To set the Energy Valve to Flow Control, set the Control Mode to Flow Control in the Setting area of the Web View, under Configuration Control Function. Refer Web View settings table on page 33.

Flow Control Application

Use Flow Control to achieve pressure independent valve performance. The valve will react to changes in system pressure to match the flow setpoint from the controller.

Flow Control Sequence of Operation

The Energy Valve uses its ultrasonic or magnetic flow meter and logic to throttle its characterized control valve (CCV) to maintain the flow set point. The valve will respond to the DDC flow analog signal except when the current flow is within $\pm 5\%$ of the signal.

When the Delta T Manager is enabled, it will activate its logic when the actual ΔT drops 2°F below the dT Setpoint. It does that by throttling the valve close until the dT setpoint is reached. The Energy Valve will resume its normal operation based on the DDC signal when the DDC setpoint drops 5% of V_{max} below the Delta T Manager's current flow. The Delta T Manager will not operate when the flow is below 30% of V_{max} . In addition, the Delta T Manager minimum flow will always be greater than 30% of V_{max} . The flow also needs to be above 30% of v_{max} for 5 minutes before the Delta T Manager will engage. 30% is the default however for specific applications it is possible to operate the Delta T Manager down to 10% of V_{nom} . This setting is available in Webview on the settings tab under the Delta T Management section.

The Energy Valve is pressure independent over its entire throttling range with available differential pressure from 1-50 psid. When the available differential pressure is less than 5 psid, refer to the Flow Reduction Chart to verify adequate differential pressure to obtain desired V_{max} .

Power Control

To set the Energy Valve to Power Control, set the Control Mode to Power Control in the Settings area of the Web View, under Configuration Control Function. Refer to Web View Settings table on page 33.

Power Control Application

Use Power Control to achieve a precise linear power output of the heat exchanger over its operating range. Power Control combines pressure independent valve performance with temperature independent coil

performance. The valve will react to changes in system pressure and to changes in water differential temperature to match the power setpoint from the controller.

Power Control / Sequence of Operation

The Energy Valve uses its ultrasonic or magnetic flow meter and logic to throttle its characterized control valve to maintain the power set point. The valve will respond to the DDC power analog signal except when the current power is within $\pm 5\%$ of the signal.

When the Delta T Manager is enabled, it will activate its logic when the actual ΔT drops 2°F below the dT setpoint. It does this by throttling the valve close until the dT setpoint is reached. The Energy Valve will resume its normal operation based on the DDC signal; when the DDC setpoint drops 5% of V_{max} below the Delta T Manager's current flow. The Delta T Manager will not operate when the flow is below 30% of V_{max} . In addition, the Delta T Manager minimum flow will always be greater than 30% of V_{max} . The flow also needs to be above 30% of v_{max} for 5 minutes before the Delta T Manager will engage. 30% is the default however for specific applications it is possible to operate the Delta T Manager down to 10% of V_{nom} . This setting is available in Webview on the settings tab under the Delta T Management section.

With Power Control, the Energy Valve is pressure and temperature independent over its entire throttling range with available differential pressure from 1-50 psid. When the available differential pressure is less than 5 psid, refer to the Flow Reduction table on page 43 to verify adequate differential pressure to obtain desired V_{max} and associated P_{max} .

Position Control

To set the Energy Valve to Position Control, set the Control Mode to Position Control in the Settings area of the Web View, under Configuration Control Function. Refer to the Web View Settings table on page 33.

Position Control Application

Use Position Control to achieve pressure dependent valve performance or to verify control response during installation, maintenance and troubleshooting. The flow meter will report actual flow at all valve positions.

Energy Valve

Control Mode Sequence of Operation

Position Control Sequence of Operation

The Energy Valve uses position feedback and logic to throttle its characterized control valve to maintain the valve position. The valve will respond to the DDC position analog signal except when the position is within $\pm 5\%$ of the signal.

Delta T Manager Options

To configure the Delta T Manager options, set the Configuration dT-Manager in the Settings area of the Web View. Refer to the Web View Settings table on page 29.

The Delta T Manager monitors the ΔT across the coil. When the ΔT drops below the set point, the Delta T Manager logic throttles the valve close to increase ΔT above the setpoint. When the Delta T Manager is enabled, it will activate its logic when the actual ΔT drops 2°F below the dT Setpoint. It does that by throttling the valve close until the dT setpoint is reached. The Energy Valve will resume its normal operation based on the DDC signal when the DDC setpoint drops 5% of V_{max} below the Delta T Manager's current flow. The Delta T Manager will not operate when the flow is below 30% of V_{max} . In addition, the Delta T Manager minimum flow will always be greater than 30% of V_{max} . The flow also needs to be above 30% of v_{max} for 5 minutes before the Delta T Manager will engage. Two Delta T Manager options are available: dT Manager and dT Manager Scaling. 30% is the default however for specific applications it is possible to operate the Delta T Manager down to 10% of V_{nom} . This setting is available in Webview on the settings tab under the Delta T Management section.

dT Manager Application

Use dT Manager to assure circuit overflow is eliminated below the Delta T Limit Value. Limiting function can be applied to all Control Modes of operation; Flow, Power and Position. Belimo suggests using this mode with changing air mass flow rate.

Sequence of Operation

This logic when activated will limit the heat exchanger ΔT to a fixed dT setpoint by reducing valve flow. The dT setpoint is equal to the Delta T Limiting Value found in Web View settings.

dT Manager Scaling Application

This limiting function can be applied to all control modes of operation: flow and power. Building operators are assured circuit overflow is eliminated below the scaled (variable) dT setpoint. Belimo suggests using this mode with changing temperature of the inlet air flow or inlet water supply.

Sequence of Operation

This logic when activated will limit the heat exchanger ΔT to a scaled (variable) dT setpoint by reducing valve flow. The dT setpoint = (Delta T Limit Value / Flow Saturation Value) * (actual flow). The Flow Saturation Value found in Web View is a required setting for this logic.

Graphical dT Manager and dT Manager Scaling Operation

In the graphs shown below, the blue and red data points were captured by allowing the Energy Valve to operate with the Delta T Manager disable and under normal operating conditions for a sufficient period to collect data ranging from light to full load.

Unrestricted flow shown with blue data points occur when the dT manager is inactive. Restricted flow shown with red data points would be eliminated when dT Manager is active.

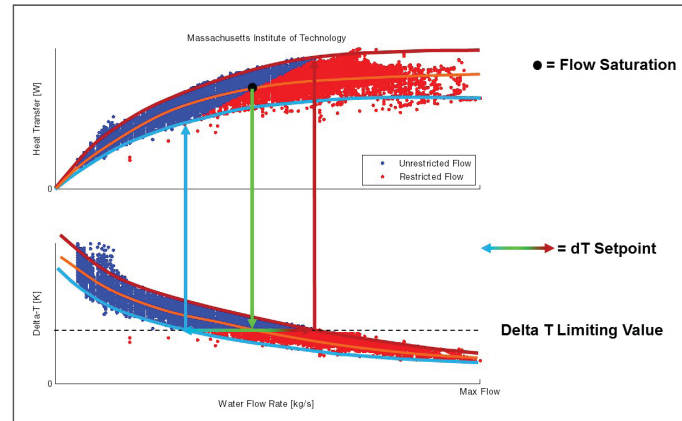

Typical Representation of dT Manager Function with Flow Control or Power Control

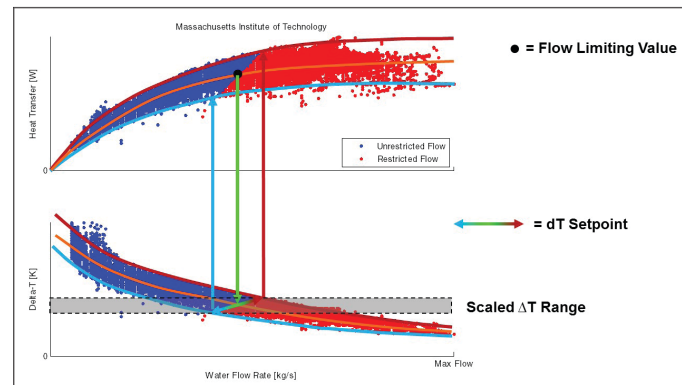

Typical Representation of dT Manager Scaling Function with Flow Control or Power Control

The Energy Valve Web View is a built-in web server that is used to configure the valve settings and view current and historical data. It can be accessed from a computer with a web browser. The Energy Valve must be connected to a TCP/IP network.

Connecting the Energy Valve to Ethernet

To configure the Energy Valve using Web View the Energy Valve must be connected to a TCP/IP network. If connecting the Energy Valve to a laptop computer directly using a **static** connection without connecting to a LAN, configure the laptop IP address to 192.168.0.200 before connecting to the Energy Valve. Then open a web browser and type in the following address in the web browser address bar: <http://192.168.0.10:8080>

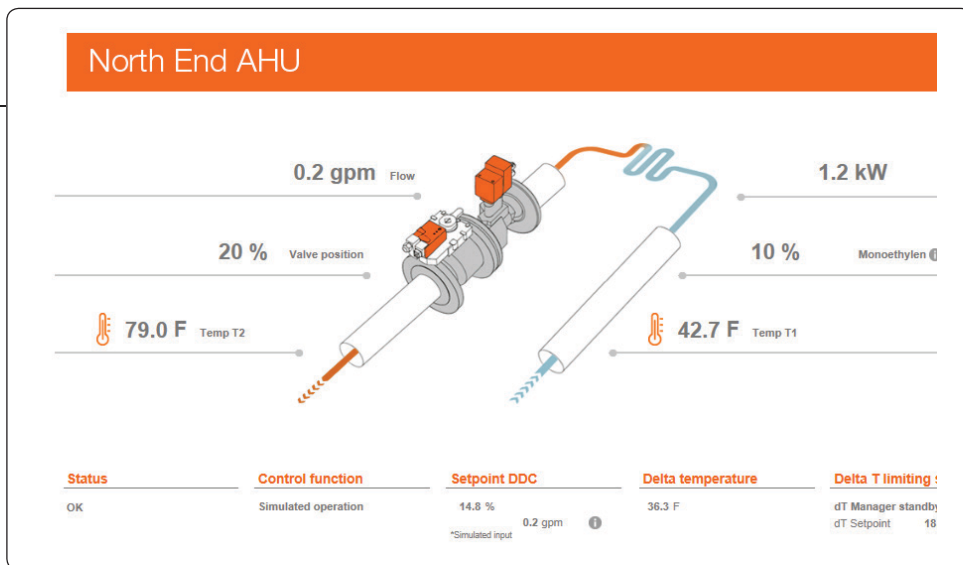

If connecting the Energy Valve to a laptop computer directly using a **dynamic** peer to peer connection without connecting to a LAN, no laptop IP configuration is required, open a web browser and type in the following address in the web browser address bar: <http://belimo.local:8080>

This address is printed on the side of the Energy Valve actuator.

Compatible Browsers

Browsers must be capable of running Javascript.

- Internet Explorer 8 or newer
- Firefox 27 or newer
- Chrome 33 or newer
- Safari 5.17 or newer
- Android browser
- Windows Phone

Login

- Access to the actuator is protected by the user name and password.
- Three default user types are available to login. Each user type has different security rights to the Web View. Refer to Web View user table below.
- Belimo cannot recover IP address. IP address can be viewed with ZTH US tool.

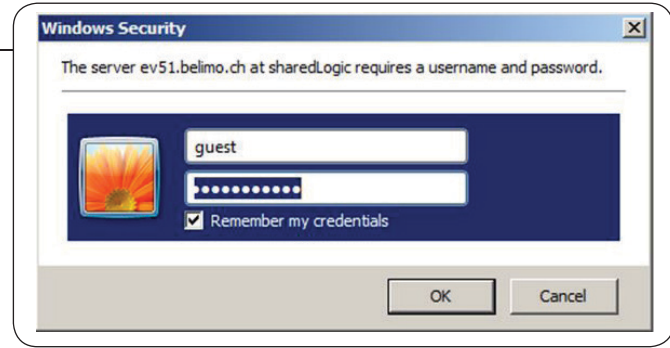

Web View User Table

Username:	Guest	Maintenance	Admin
Password*:	guest	belimo	Contact Belimo Tech Support
Web View Page			
Dashboard	Read	Read	Read
Overview	Read	Read/Write	Read/Write
Override and Trend Control	Read	Read/Write	Read/Write
Data Log Chart	Read	Read	Read/Write
Settings	Read	Read	Read/Write
Status	Read	Read/Write	Read/Write
Date & Time Settings	--	Read/Write	Read/Write
IP Settings	--	Read/Write	Read/Write
Version Information	--	Read/Write	Read/Write
Mobile	Read	Read	Read/Write
Data Logging	Read	Read	Read/Write
BACnet / MP Settings	Read	Read	Read/Write

*Password is case sensitive

The Energy Valve Web View is a graphical user interface accessed via a network or internet to set up, calibrate and change the parameters of the Belimo Energy Valve. The Web View consists of the following page views:

Overview

The overview page allows you to see the setpoint, flow, valve position, glycol percentage if activated, Delta T, and mode of operation. Double click on a heading item to see a historical trend of the data.

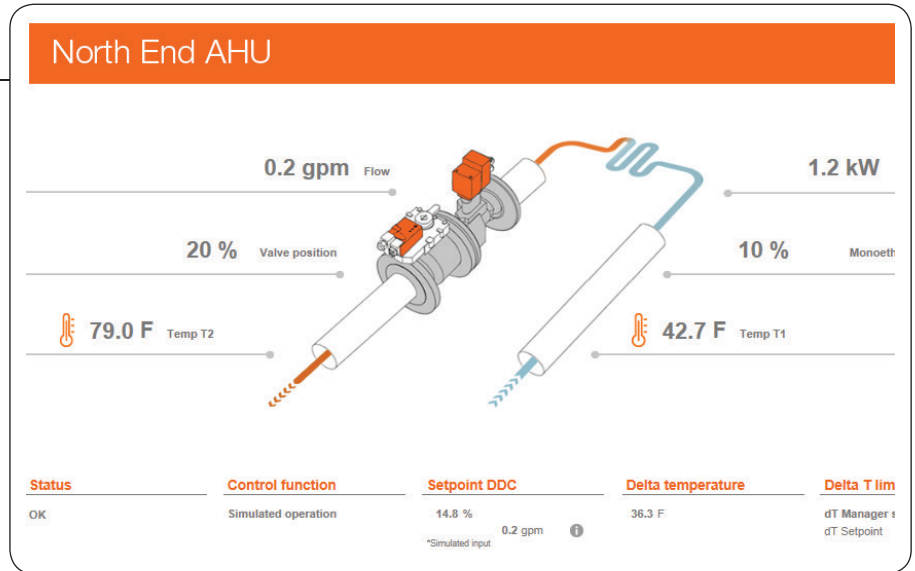

Data

An analytical view of the historical data with the ability to select the type of data to analyze; primarily used for maintenance and troubleshooting.

This view also provides key performance indicators. In addition this view also has the Delta T set point suggestion integrated. To calculate press the coil characteristic button below x axis.



Status

Status provides an error count by type and time elapsed of last occurrence. More details provides additional information with informational buttons on the possible solution to the error.

These errors can be reset to zero and should be reset after commissioning to clear any errors that may have occurred due to the valve and system not being fully operational.

Description	
Media	OK
Flow sensor	OK
Power	OK
Sensor	OK
Actuator	OK

History	counter
Total errors seen	3

[Show details](#)

Settings

Access and adjust the operating settings. Refer to Web View Settings table on page 33.

Belimo Energy Valve 1/2" | DN 15

Vnom 5.5 gpm Pnom 80 kW

[Start assistant](#) [Commissioning report](#)

[Settings import](#) [Settings export](#)

Configuration

Units

Temperature: F

Flow: gpm

Power: kW

Energy: MWh

Application

Installation position: Valve in return pipe

Remote sensor cable length: 5m

Media: Monoethylen

Glycol override:

Analog feedback

Feedback: Flow

Range: 2 - 10 V

Maximum: 5.5 gpm

Override

Simulated operation Time back to Auto: 1940 h 52 min

Control settings

Control mode: Flow control

Signal characteristic: equal percentage

Setpoint source: Analog

Control signal range: 2 - 10 V

Invert signal: not inverted

Maximum and limitation

Vmax: 5.5 gpm

Vmin: Range: 1.7 - 5.5

Delta T Manager

dT Limiting function:

dT Limiting value: 18.0 F

Range: 1.8 - 100.0

Configuration Options

Date and Time Settings

Provides different ways to set the date and time. It allows the time to be entered manually, synchronized through a computer, or synchronized with a Time Server.

If BACnet communication is enabled, Local Client Date and Time will be automated through BACnet.

Local Client

11:36:31 Time

07.02.2017 Date

GMT-5 Timezone

Remote Node

17:35:38 Time

07.02.2017 Date

CET Timezone

Synchronize Time

NTP Server (optional)

Local RTC

Time Server

IP Address Timeserver

Submit

IP Settings

To configure the valve communication on a TCP/IP network. It allows the valve to have a dynamic IP address (requires an active DHCP server) or a static IP address (requires an IP address, Network Mask and Gateway address from IT manager). The Broadcast address will be generated automatically.

The DNS Servers are listed here for default. If different are preferred they will need to be assigned by the customer IT infrastructure responsible for the Energy Valve installation.

Network configuration

50:2D:F4:07:B8:B5 MAC address

DHCP/Zeroconf

Static/Zeroconf

192.168.0.10 IP address

255.255.255.0 Network mask

192.168.0.1 Gateway

208.67.220.220 DNS nameserver 1

8.8.8.8 DNS nameserver 2

192.168.0.255 Broadcast address

169.254.1.1 ZeroConf Address

Change IP configuration

Version Information

Displays current software version.

Hardware

21701-20005-022-069 Serial Number

13188-00004 OC Module Material Number

Software

9.3.3G20 Operating System Version

2.15.0 Core Software Version

1.12.4 Communication Module Firmware Version

Application Model

ev-app-3-09-324 Model Name

ev-app-3-09-324-021500.bcz Model File Name

3.9.324 Model version

Data Logging

Location to download all the historical data in a spreadsheet (.csv) that can be uploaded to the Data Analysis Tool™ for further analysis. See Data Analysis Tool™ page.

Filetype

Short Term Storage (31 Days uncompressed)
 Long Term Storage (Compressed)

Filename

Default Datalog Configuration-2017-02-03.csv
Default Datalog Configuration-2017-02-04.csv
Default Datalog Configuration-2017-02-05.csv
Default Datalog Configuration-2017-02-06.csv
Default Datalog Configuration-2017-02-07.csv
Default Datalog Configuration-2017-02-08.csv
Default Datalog Configuration-2017-02-09.csv

Download Erase Data Log Select all files

User Administration

Add, delete and edit including password management for users. See Webview User table for User profiles.

Web Users

Show 10 entries Search:

Name	Group
admin	adminGroup
guest	guestGroup
maintenance	maintenanceGroup

Showing 1 to 3 of 3 entries Previous 1 Next

Delete Selected User Edit Selected User Add User Reset

Maintenance

Maintenance: Configuration Import /Export

This feature allows the Energy Valve settings to be downloaded (export configuration) from one valve and imported to another valve via an XML file format. The valve size and actuator type need to be the same for this function.

Activation Codes: This feature is for uploading a code for additional features such as glycol monitoring. This code and pricing can be provided by Belimo Technical support.

Update: Last Update indicates the status of updates for security and operational performance.

No Updates applied – none of available have been executed.

Update available in cloud.

No new updates available

Apply Available Updates

Executes downloaded updates

Upload and Apply Update File

Downloads available updates and executes

Configuration Import/Export

Browse... Import Configuration

Export Configuration

Activation Codes

Feature Name	Feature Id	Creation Time	Period Start	Period End

Browse... Upload And Apply Activation Code

Update

Last update:
 No update applied: No update applied.
 Update available in cloud:
 No new update available.

Apply Available Updates Upload And Apply Update File

Misc

Reboot Factory Reset

Misc: Reboot - Performs the function of power cycling the actuator for a restart. Factory Reset restores the Energy Valve actuator settings to settings when it left the Belimo factory.

BACnet, MP-Slave and Modbus Settings

This page is used to set the type of communication and settings for the Energy Valve. All BACnet configurations must be set prior to connecting to the BACnet network to avoid communication and settings problems.

- BACnet is a building automation communication protocol worldwide standard.
- MP is a Belimo protocol that allows for communication to multiple Belimo devices at the same time.
- Modbus is also a building automation communication protocol
- None is the default value, when selected the valve will not communicate via BACnet.

BACnet, MP-Slave and Modbus Settings

Communication Protocol

- BACnet IP
- BACnet MS/TP
- MP
- Modbus TCP
- Modbus RTU
- None

BACnet IP Settings

Port: The UDP port value defaulted to 47808

Simple/Foreign Device: A Simple Device requires communication only on its own IP subnet, or there is a BBMD device on its subnet to handle routing of broadcast messages between subnets. A Foreign Device communicates to devices on subnets other than its own and to do so, must register with a BBMD device on a remote subnet.

Instance ID: A unique ID number for the EV device object on the BACnet network (between 0 and 4194303). This is ***not*** a read only value.

Device Name: Name used to represent the device in the BACnet system.

Device Description: General detail of the device.

System Status: Indicates that the valve is operational. A read only value. 0 is operational, 1 is not operational.

Protocol Version and Revision: These are read only values to show the BACnet protocol version and revision that the communication software follows.

IP BBMD: IP address entered must be the address of the BBMD router on a different subnet.

Time to Live: The time in seconds between updated registrations with the BBMD router. If your BBMD router has a TTL setting, this value should match the router's.

Communication Protocol

- BACnet IP
- BACnet MS/TP
- MP
- Modbus TCP
- Modbus RTU
- None

BACnet IP Settings

47808 Port

- Simple Device
- Foreign Device

Device Object Settings

4096 Instance ID
 EV55 Demo Device Name
 DeviceDescription Device Description
 0 System Status
 1 Protocol Version
 12 Protocol Revision

Submit

- Simple Device
- Foreign Device

127.0.0.1 IP BBMD

30 Time-to-Live



BACnet MS/TP Settings

Baud Rate: The transmission speed within the MS/TP network. All devices on the same network must be set to the same baud rate. Available rates: 9600, 19200, 38400, 76800, 115200.

MAC: The MAC address on the MS/TP network. This number must be unique within the network. Available values range from 1 to 127.

Max Master: Max_Master must be large enough that all MS/TP MAC addresses are within it. If unsure, set to 127.

120 Ohm Termination: MS/TP networks require termination resistors on end-of-line devices. Turning on this setting will provide the required 120 Ohm termination on this BACnet device. Use this setting with great caution as adding termination resistance on a device in the middle of a network can cause significant network problems.

Instance ID: A unique ID number for the EV device object on the BACnet network (between 0 and 4194303). This is *not* a read only value.

Device Name: Name used to represent the device in the BACnet system.

System Status: Indicates that the valve is operational. A read only value. 0 is operational, 1 is not operational.

Protocol Version and Revision: These are read only values to show the BACnet protocol version and revision that the communication software follows.

MS/TP Device Load: The MS/TP interface on the Energy Valve will create a 5/8 unit load on the network. This is a combination of local biasing resistors and a 1/8 load EIA-485 driver chip. Please keep this load figure in mind while determining network device limits and repeater requirements. For reference, the EIA-485 specification allows for a total of 32 device loads on a network without using repeaters. The transceiver is isolated, but the isolated reference is not exposed due to lack of pins 47K pull up resistors are connected from the isolated common to - and isolated 5v to + and is fail safe.

BACnet, MP-Slave and Modbus Settings

Communication Protocol

BACnet IP
 BACnet MS/TP
 MP
 Modbus TCP
 Modbus RTU
 None

BACnet MS/TP Settings

Baud rate
 MAC Address
 Max Master
 120 Ohm Termination

Device Object Settings

Instance ID
 Device Name
 Device Description
 System Status
 Protocol Version
 Protocol Revision

Modbus TCP Settings

TCP Unit ID: Each device in a network is assigned a unique unit address from 1 to 247.

Default Value: 1

TCP Port: Modbus is a serial communications protocol for client-server communication between a switch (server) and a device in the network running Modbus client software (client), A client sends a message to a TCP port on the switch.

The listening TCP port 502 is reserved for Modbus communications. It is mandatory to listen by default on that port. However, some markets or applications might require that another port is dedicated to Modbus over TCP.

This is the case when interoperability is required with non =S=products, such as in Building Control. For that reason, it is highly recommended that the clients and the servers give the possibility to the user to parameterize the Modbus over TCP port number. It is important to note that even if another TCP server port is configured for Modbus service in certain applications, TCP server port 502 must still be available in addition to any application specific ports.

Keep Open timeout [seconds]: How long a device can take to respond before it is considered a timeout

Default Value: 30 seconds

BACnet, MP-Slave and Modbus Settings

Communication Protocol

- BACnet IP
- BACnet MS/TP
- MP
- Modbus TCP
- Modbus RTU
- None

Modbus TCP Settings

1 Modbus Address

502 TCP Port

30 Keep open timeout [seconds]

Submit

Modbus RTU Settings

Modbus Address: Each device in a network is assigned a unique unit address from 1 to 247.

Default Value: 1

Range: 1-247

Baud rate: The transmission speed within the Modbus RTU network. All devices on the same network must be set to the same baud rate.

Default Value: 38400

Range: 9600, 19200, 38400, 76800, 115200

Parity: The transmission format used by Modbus that indicates the start bits, data bits, parity and stop bits.

Default Value: 1-8-N-2

Range:

1-8-N-1 (1 start, 8 data, no parity, 1 stop bit)

1-8-N-2 (1 start, 8 data, no parity, 2 stop bit)

1-8-E-1 (1 start, 8 data, even parity, 1 stop bit)

1-8-O-1 (1 start, 8 data, odd parity, 1 stop bit)

BACnet, MP-Slave and Modbus Settings

Communication Protocol

- BACnet IP
- BACnet MS/TP
- MP
- Modbus TCP
- Modbus RTU
- None

Modbus RTU Settings

1 Modbus Address

38400 Baud rate

Termination

1-8-N-2 Parity

Submit

Cloud Setting

Datalog Service Connection Status: The status of the cloud connection.

Cloud Server: The address of the connected host Server.

MAC Address: The MAC address of the connected Energy Valve.

Datalog Service: Allows for data transfer between the Energy Valve and the cloud.

Task Service: Allows for automatic updating of the Energy Valve flow and Delta T setpoints based on data captured by the valve in the cloud.

Update Mode: Allows for automatic updating of the Energy Valve flow and Delta T setpoints based on data captured by the valve in the cloud.

Disabled: No updates are downloaded.

Device_Controlled: Updates are shown on the Maintenance page in Webview and not installed automatically, they are offered.

Cloud_Controlled_Manual: The updates need to be released by the device owner in the cloud. The device installs the update immediately after release.

Cloud_Controlled Auto: The updates are released by Belimo and propagated to the devices. The device installs the update immediately after release.

Current owner: The individual that has current ownership of the device.

This is typically the name of the user that configured the cloud settings and corresponds to the email address provided on initial set up.

Refresh Current owner: Simple refresh button to explicitly ask the cloud to tell us the current owner (for example after the product was transferred in the cloud).

New owner: Used when starting a transfer from a current owner (or no owner yet) to a new owner which requires pressing the Transfer device button after new owner is entered.

Additional Information: By clicking on the load button displays more ownership information and device details.

Connection Status: Runs a routine that will help troubleshoot connection to the Belimo cloud.

Connection setup

Connectivity Requirements:

Customer provided Ethernet Cable
Dedicated Internet Connection

Requirements for cloud connection

Gateway IP Address that allows a route to the internet
In case of DNS restrictions: IP addresses of internal DNS servers

Communication details

Used protocol is https
Port of the server endpoint: 443
DNS address of cloud server: <https://connect.g2bcc.com>

Firewall rule to allow communication

Action: Pass / Allow
Address family: IPv4
Protocol: https over TCP
Source: IP address of device or subnet designated to EnergyValve devices
Destination: <https://connect.g2bcc.com>

Daily Data Volume

Approximately 10MB

Communication between device and cloud

All communication between the device and the cloud is encrypted. The data is not readable without de-encryption.

Local configuration

In order to configure the device, the local webpage running on the integrated webserver has to be reached. The steps necessary depend on the local network setup and can vary. The easiest way to open the webpage is a direct LAN connection with a laptop running Windows and using the address <http://belimo.local:8080> (the port number is 8080). Alternatives include, but are not limited to: using a wireless access point that connects to the device by LAN cable, then use any portable device with a web browser to open the webpage from any internal network location if the LAN setup, especially routing and switching settings are appropriate using a direct LAN connection with the correct network settings (IP address and subnet mask) and accessing the device with its initial fixed IP (e.g. <http://192.168.0.1:8080>)

The website asks for login credentials. In order to configure the device for cloud access including network settings an admin user type is necessary. The login credentials for the admin user are not publicly available, but communicated through customer support. The user is forced to change the admin password while completing the installation assistant.

There is an initial installation assistant as well as a manual method to configure the device to access the cloud. The following user data is requested when the user wants to enable cloud functionality:

Mandatory data:

Cloud E-Mail Account (valid E-Mail address, note: no need that this E-Mail address already is a valid Belimo cloud account)

Cloud Connectivity Quick Start Guide

1. Locally Configure IP Settings on Actuator using LAN connection and laptop via <http://belimo.local:8080>

The screenshot shows a web interface for network configuration. On the left is a navigation menu with options: Overview, Data, Status, Settings, Configuration, Date & time settings, IP settings (highlighted), Version information, Data logging, User administration, Maintenance, BACnet/MP/Modbus settings, Cloud Settings, Language (English), and Logout. The main content area is titled 'Network configuration' and contains the following fields:

- MAC address: 50:2D:F4:07:B4:98
- IP address: 192.168.49.55
- Network mask: 255.255.255.0
- Gateway: 192.168.49.1
- DNS nameserver 1: 208.67.222.222
- DNS nameserver 2: 114.114.114.114
- Broadcast address: 192.168.49.255
- ZeroConf Address: 169.254.15.184

At the bottom of the configuration area is a button labeled 'Change IP configuration'. Radio buttons are present for 'DHCP/Zeroconf' and 'Static/Zeroconf', with 'Static/Zeroconf' selected.

2. Ownership Information and acknowledgement of cloud services.

When the actuator is powered up initially the installation assistant is run and relevant cloud setup information like device owner and email address is entered as well as some valve set up information. To ensure this is complete the set up assistant can be started again by clicking the start wizard icon on the submenu application under the settings menu heading.

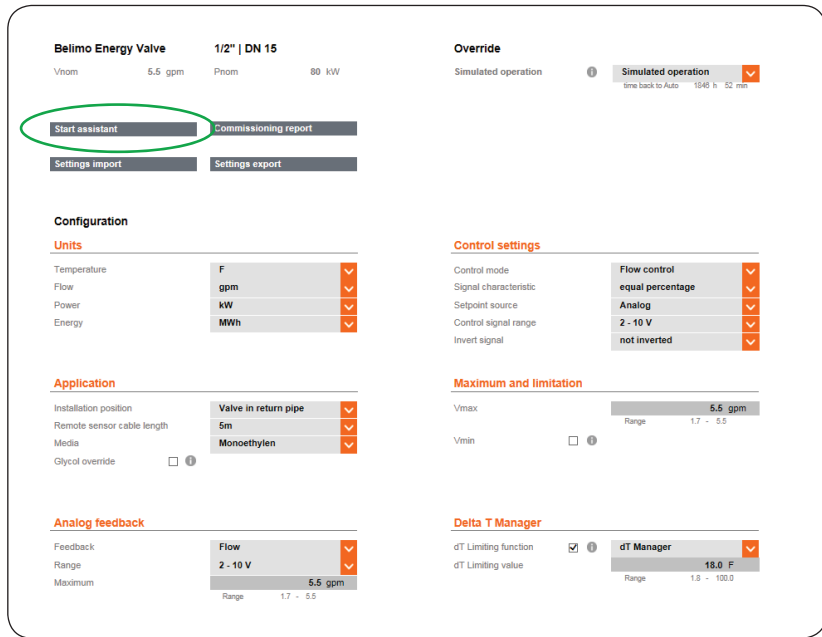

3. Once actuator has been locally configured with appropriate IP address, email address, device owner and acknowledgement of cloud services, connect live Ethernet cable and log back into the actuator via the IP network to verify connection to the Belimo cloud.

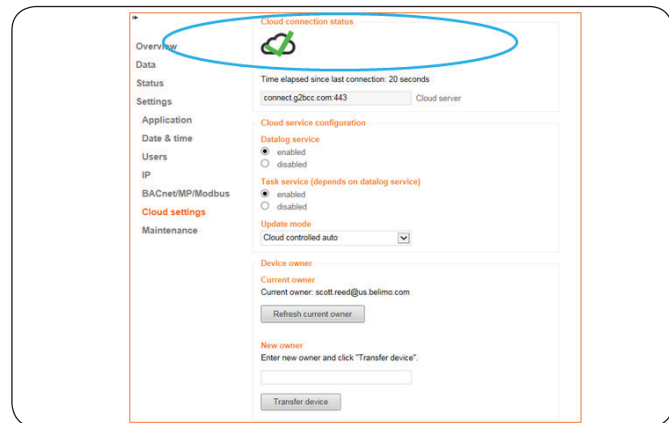
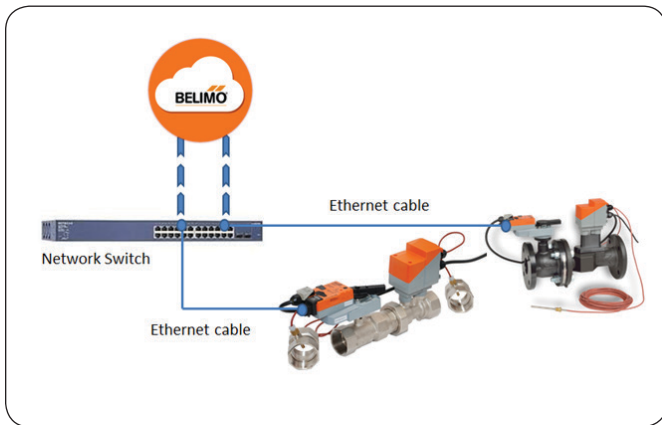

4. Go to cloud.belimo.com to create an account and allow device entrance into the cloud. The email address entered when completing the set up wizard will be required when creating the cloud account.

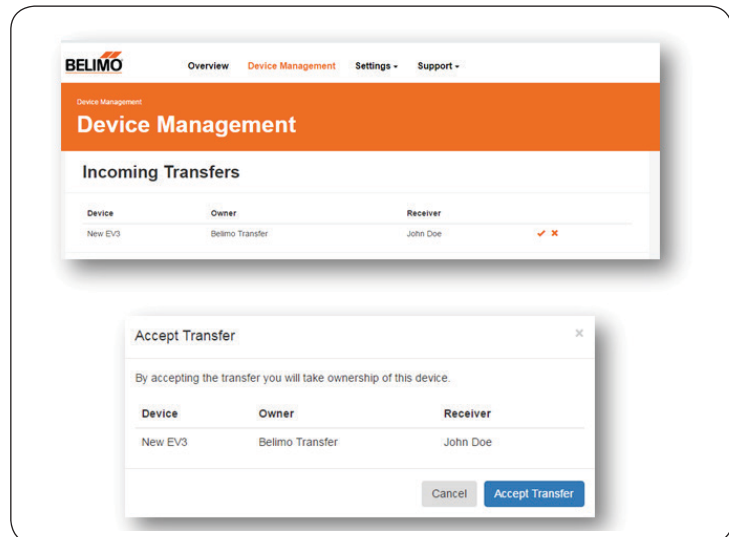

5. Once connected the following services will be available:

Delta T Optimization and Flow Setpoints

Cloud analytics provide recommended Delta T and flow setpoints which can be updated remotely or automatically to save time and improve efficiency.

Performance Reporting

Key performance indicators are graphically illustrated showing current and historical performance data of flow rates, energy usage, Delta T, and other points of interest.

Lifetime Data Access

Secure, single consolidated repository that stores and provides system data access for future optimization.

Online Tech Support

Belimo's industry leading technical support team available to assist you remotely.

Software Updates

Latest software and security updates automatically provided for maximum productivity and reliability.

Extended Warranty

5-year warranty is increased to 7-year with Belimo cloud connection.**

**The following provision supplements the applicable Terms and Conditions of Sale for the Energy Valve 3.0. The 5-year warranty foreseen in the Terms and Conditions of Sale shall be replaced by a 7-year warranty, provided the following conditions are fulfilled:

- The Cloud-connection on the respective BELIMO device is activated
- The respective BELIMO device has been allocated to a Cloud-Account
- At the time of the warranty claim the connection ratio between the BELIMO device and the BELIMO-Cloud is at least 90% (the connection ratio is determined by the amount of hours of Cloud-connection of the BELIMO device divided by its operating hours).

Cloud Interface

Overview Page

Status of Devices:

Provides Total Energy Valves for associated account. Only valves for the account will be displayed. Also indicated here is if there are problems with the device in terms of operation that may need attention and if there are valves coming in or leaving the cloud via transfer.

Devices:

Displays the device name which is assigned in Webview by the user, Health status, Serial Number of the Energy Valve and the current device owner. Clicking on the action folder displays the Valve data points, ability to download data, Valve details and transfer capability.

Device Management Page

Provides a single page focused on managing the Energy Valve in the cloud. Displays the device name which is assigned in Webview by the user, Health status, Serial Number of the Energy Valve and the current device owner. There is also search functionality that allows for search by serial number or Energy Valve name.

Under the Action heading are 3 specific functions:

1. Transfer Energy Valve from one owner to another by clicking on the orange arrow. To have data available for the new owner, the option of with data should be selected. This appears once the transfer icon is clicked.
2. Display Valve data points, ability to download data, Valve details and transfer capability by clicking the action folder.
3. Delete the selected Energy valve from the cloud by clicking the trash can icon.

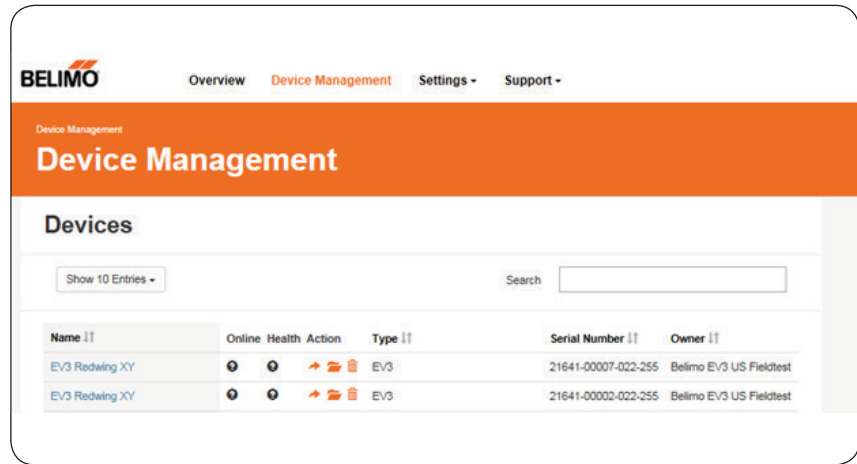

Settings Page

Provides page focused on the information for two main areas Account Settings which includes information about the user/owner including Name, Geographic information, Email address, and current password as well as ability to change current password. Also My User Groups which displays the current user groups and ability to create a new group and add members to it.

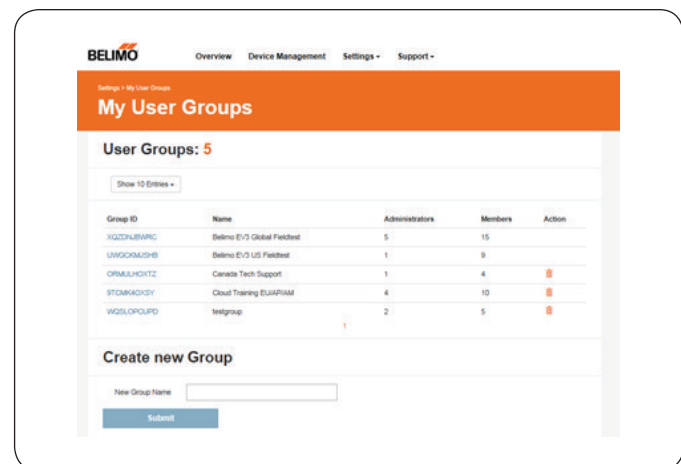
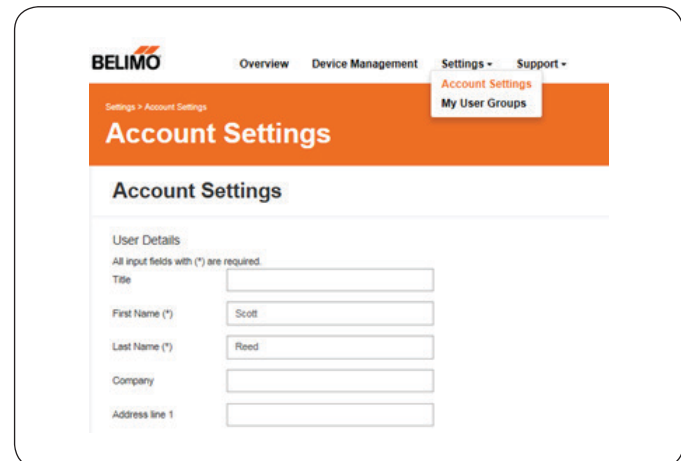

Transfer Energy Valve From One Owner to Another or Group

Cloud Interface **BELIMO**

- Transfer Energy Valve from one owner to another or group
 - Step 1: On Device Management Page under Action Click Request Device transfer

Device Management

Devices

Name	Online	Health	Action	Type	Serial Number	Owner	City	Country	Project
Canada Demo	✓	🟢	🔴	EV3	21629-00081-001-160	Scott Reed	Danbury	US	Deploy
Demo EV59	✓	🟡	🔴	EV3	21714-10125-001-139	Testing	Hewitt	CH	P801135

EXPERIENCE EFFICIENCY

Cloud Interface **BELIMO**

- Transfer Energy Valve from one owner to another or group
 - Step 2: Enter email address or Group ID, Group ID is found on Settings page

Transfer Device

Warning! After you have transferred the device to a new owner you will not be able to access the device or its data. This action cannot be undone.

Recipient
Enter the email address or the group ID of the target owner

JVCNQDZ3RY

With Data

ID	Name	Owner	Transfer
0306468-418-4035-9694-906842...	Demo EV59	Testing	

Cancel Execute Transfer

My User Groups

User Groups: 2

Group ID	Name	Administrators	Members	Admin
JVCNQDZ3RY	Public Demo	3	6	

EXPERIENCE EFFICIENCY

Cloud Interface **BELIMO**

- Transfer Energy Valve from one owner to another or group
 - Step 3: Select with Data to have data of the device carried over and execute transfer

Transfer Device

Warning! After you have transferred the device to a new owner you will not be able to access the device or its data. This action cannot be undone.

Recipient
Enter the email address or the group ID of the target owner

JVCNQDZ3RY

With Data

ID	Name	Owner	Transfer
0306468-418-4035-9694-906842...	Demo EV59	Testing	

Cancel Execute Transfer

EXPERIENCE EFFICIENCY

Cloud Interface **BELIMO**

- Transfer Energy Valve from one owner to another or group
 - Step 4: Go to Device Management page and accept incoming transfer

Device Management

Incoming Transfers

Device	Owner	Receiver
Demo EV59	Testing	Public Demo

Outgoing Transfers

Device	Owner	Receiver
Demo EV59	Testing	Public Demo

Devices

EXPERIENCE EFFICIENCY

Support Page

Provides relevant support information, Contact for Belimo Headquarters, Support Request, API Developer Documentation and Delta T Optimize Request. For the Delta T Optimize request it requires at least 2 months of data for proper analysis.

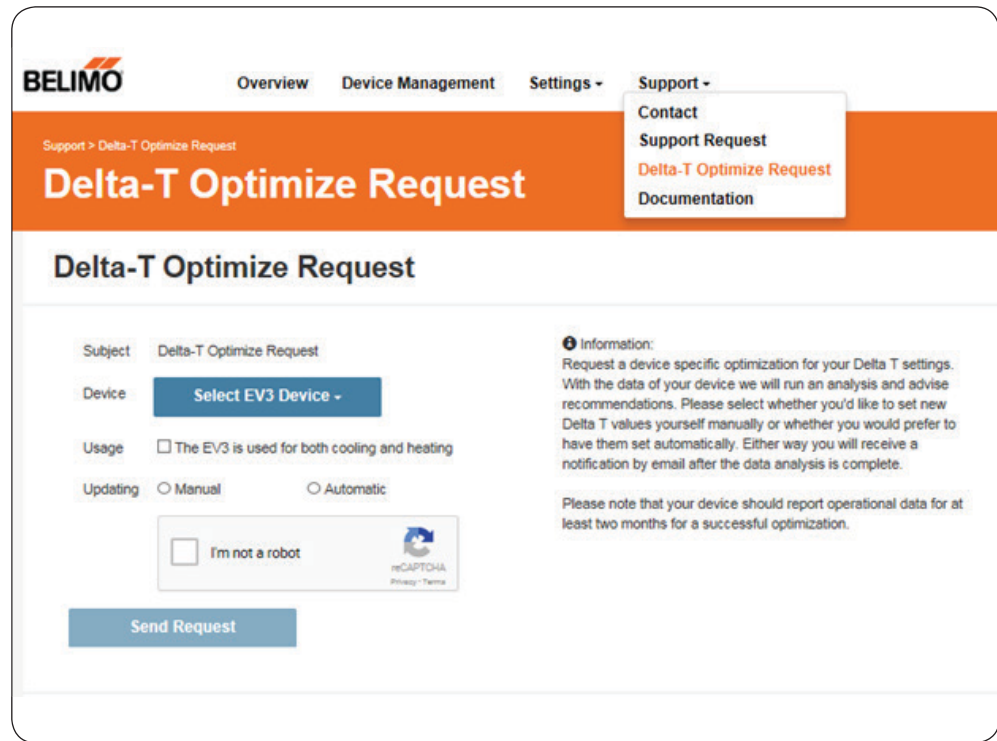

Field Programming and Commissioning Options

All Energy Valve actuators can be field programmed with either the ZTH US handheld tool or with an Ethernet cable connected to a computer with web browser to access the actuator's web page (Web View). Refer to the table below for a list of settings that can be changed in the field.

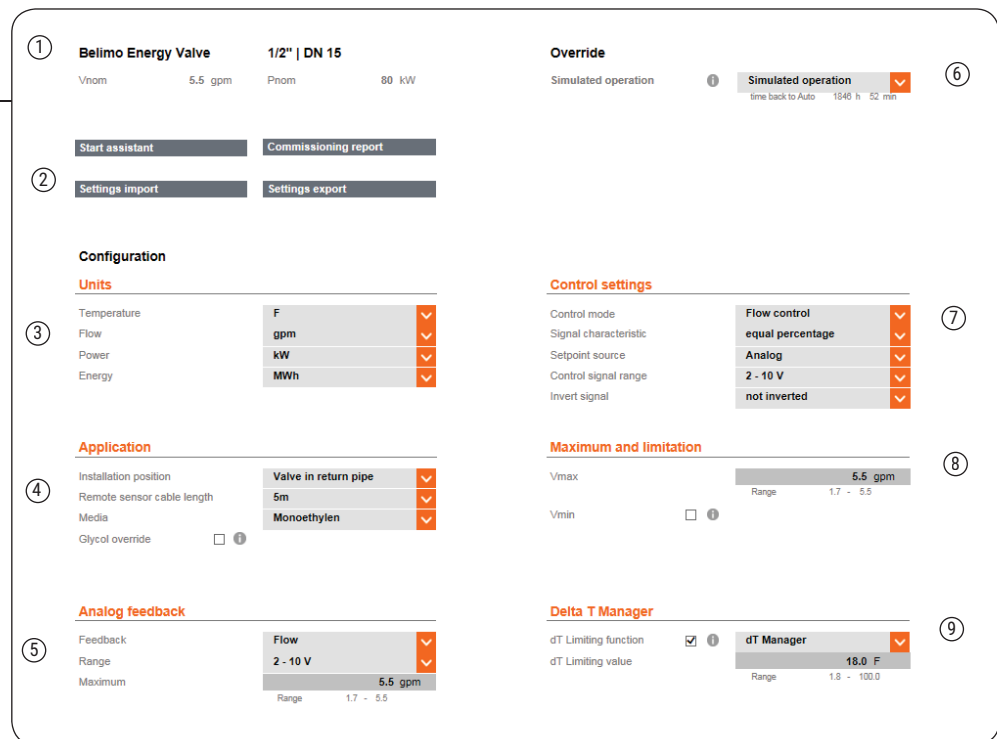

Tech.Doc - 06/20 - Subject to change. © Belimo Aircontrols (USA), Inc.

Web View Settings

TAB	SETTING	FUNCTION	DEFAULT / RANGE
1. General Information	Valve Size	Defines the full flow cataloged capacity (V _{nom}) of the valve.	(Default factory set to the valve size) ½" – 6" [DN 15 – DN 150]
	Set Up Assistant	A set up routine that runs on first power up to assist the installer with configuring the valve. Can also be run again by selecting here and any changes made will be applied.	N/A
2. Functions	Import/ Export	Allows the export of valve settings and Import into another valve in XML Format.	N/A
	Commissioning Report	Generates a PDF of valve configuration settings for records.	N/A
3. Units	Temperature	Units: water supply, return, and delta T.	Fahrenheit Celsius, Kelvin
	Flow	Units: water flow rate through the valve.	GPM M3/s, M3/h, l/s, l/min, l/h
	Power	Units: thermal power through the valve.	kBTU/h W, kW, BTU/h, Ton
	Energy		kBTU J, kWh, MWh, kBTU, Ton H, MJ, GJ
4. Application	Installation Position	Identify the installed water service location of the valve and its embedded temperature sensor, or piped in series with the valve (T2). The sensor w/ longer cable is remote (T1) and will be assigned opposite the water service of the valve.	Valve in Return Pipe Valve in Supply Pipe
	Cable Length Remote Temp Sensor	Cable length selection (for proper operation do not cut cables). Remote sensor cable length settings adjusts wire resistance to accurately calculate thermal power and energy.	1/2" - 2" models 9.8 ft. [3 M] 4.9 ft. [1.5M] 2 1/2" - 6" models 32.8 ft. [10 M] 16.4 ft. [5 M] 9.8 ft. [3 M] 4.9 ft. [1.5 M]
	Media	Water or water/glycol composition used to accurately calculate: flow, thermal power and energy.	Water Monoethylene Glycol Polyethylene Glycol

Tech.Doc - 06/20 - Subject to change. © Belimo Aircontrols (USA), Inc.

Web View Settings Continued

TAB	SETTING	FUNCTION	DEFAULT / RANGE
5. Analog Feedback	Feedback	Actuator analog feedback signal output on wire #5 u-signal.	Flow Power, T supply T return, delta T Valve position
	Range	Actuator analog feedback linear signal range.	2-10 V 0.5-10 V 0-10 V
	Maximum	Setting to equate 10 VDC or maximum feedback information. Setting must match the DDC range maximum setting. The grey box is an entry field and not the actual measured feedback and will hold the last value entered in it. The factory setting on this is 0.	Flow 0 to V'Nom <u>Position</u> 0 to 100% (0-90 deg.) <u>Temperature</u> 32°F to 212°F 0°C to 100°C <u>Power</u> 0 to P'nom
6. Override	Override functions	Override functions to move the valve to a particular point or position which can be used for testing and commissioning purposes. All engaged overrides stop and go back to normal operation automatically after two hours.	
	Auto	Normal operation no override.	Auto
	Close	Moves actuator to close valve.	N/A
	Open	Moves actuator to open valve.	N/A
	V'nom	In flow control moves the actuator to full open position.	N/A
	V'max	In flow control moves the actuator to V'max setting.	N/A
	Motor Stop	Stops the valve at current position.	N/A
	P'Nom	In power control mode moves the actuator to P'nom position (full open).	N/A
	P'max	In Power control mode moves the actuator to P'max setting.	N/A
Simulated operation	Engages simulation of flow and temperature that can be viewed on the overview page.	N/A	
7. Control Settings	Setpoint Source	Defines how the BMS valve set point is sent to the actuator either analog on wire 3 or via BACnet, Modbus or MP).	Analog Bus (BACnet, Modbus, MP)
	Control Mode	Controlled variable assigned to the actuator analog input y-signal, wire # 3.	Flow Control Power Control Position Control
	Invert Signal	"No" valve modulates open when 10 VDC is received. "Yes" 10 VDC signal closes the valve.	No Yes
	Signal Characteristic	Setting when Controls modes are set to Flow or Position <ul style="list-style-type: none"> Equal Percentage flow yields coil thermal power roughly Equal to the control signal. "linear" 50% controller command yields 50% flow output or position. 	Equal Percentage Linear
8. Maximum and Limitation	Vmax	Used with Flow Control mode, this is the maximum flow setting of the valve with a full flow output from the controller.	V'Nom
	Vmin	Used with Flow Control mode, this is the minimum flow setting of the valve to maintain a minimum flow rate for particular applications.	30% - 100% of V'nom Defined by size in Webview

Tech.Doc - 06/20 - Subject to change. © Belimo Aircontrols (USA), Inc.

Web View Settings Continued

TAB	SETTING	FUNCTION	DEFAULT / RANGE
9. Delta T Manager	Delta T Limiting Function	Setting to disabled or enabled with limiting logic: dT Manger or dT Manager Scaling. Both use settings "Delta T Limiting Value" but only dT Manager Scaling uses the "Flow Saturation Value."	Disabled = "-" dT Manager dT Manager Scaling
	Delta T Limiting Value	Low limit parameter for dT setpoint: <ul style="list-style-type: none"> For dT Manger this is the dT setpoint. For dT Manager Scaling this will reset so the dT setpoint is scaled, or variable. The Data Analysis Tool may be used to help determine this value. The grey box is an entry field and not the actual measured Delta T and will hold the last value that is entered in it.	10°F 2°F to 100°F 1.1°C to 55.5°C Default >30% of V'max Option >10% of V'nom
	Flow Saturation Value	Parameter used with dT Manager Scaling to reset the Delta T Limiting Value. When dT Manager Scaling is active: <ul style="list-style-type: none"> If actual flow is less than this parameter the dT setpoint will be reset below the Delta T Limiting Value. If actual flow is equal to this parameter the dT setpoint will be equal to Delta T Limiting Value. If actual flow is greater than this parameter the dT setpoint will be reset above the Delta T Limiting Value. The Data Analysis Tool may be used to help determine this value.	(User defined) >30%-100% of V'max

The ZTH US is a tool created to easily adapt the flow settings of the Energy Valve in the field. It directly connects to the Belimo actuator.

CONNECTION PROCESS:



LR, NR, AR, GR, AKR, GKR, EV, AVK Series
Use the interface on the top of the actuator. Quarter turn to lock in place. Connect the other end of the cable into the ZTH US. The actuator must be powered for the ZTH US to function. (Leave all of the wires of the actuator installed.)



Technical Information

Supply	24 VAC/DC
Communication	PP
Used with actuator types	LR, NR, AR, GR, AKR, GKR, EV, AVK

RE-PROGRAMMING PROCESS:

Initial Screen

When connected the display will show "Startup Progress" this process will take approximately 30 seconds.



Screen 1

Start Energy Valve process by pressing the down arrow. The first screen displays setpoint relative in % (SpRel). Press the down arrow to advance.



ZTH US SETTINGS

Move through the displays. The chart below shows the complete list.

Setting	Description	Range and UOM	Capability
SpRel	Analog Input signal as a % of full signal	0 – 100%	Read Only
RelPos	Valve position as a % of full opening	0 – 100%	Read Only
RelFlow	Current flow as % of V'max	0 – 100%	Read Only
AbsFlow	Flow in GPM	GPM	Read Only
T1 remote	Temperature opposite valve side	F	Read Only
T2 embedded	Temperature at valve	F	Read Only
DeltaT	Supply and return temperature differential	F	Read Only
RelPower	Current power as % of P'max	%	Read Only
Abs power	Current power output	KBTU/hr	Read Only
Cooling Energy	Total cooling power since last reset	KBTU	Read Only
Heating Energy	Total heating power since last reset	KBTU	Read Only
Override	1=Auto, 2=Close, 3=Open, 4=V'nom, 5=V'max, 6=MotorStop, 7=P'nom, 8=P'max, 9=Set Point Position Override	1-9	Write Only
SpPos Override		0 – 100%	Write Only
Mode	(0 = 0.5 – 10 V, 1= 2 – 10 V)	0 - 1	Write Only
ModeY Inv	(0 = not inverted, 1= inverted)	0 - 1	Write Only
V'max	Can be a percentage or flow.	30 – 100% 0 – 1000GPM	Write Only
P'max	Can be a percentage or power	1 – 100% 1 – 15000KBTU/hr	Write Only
Control Mode	0=Position Control, 1=Flow Control, 2=Power Control	0 - 2	Write Only
Install Pos	0= Return Flow, 1= Supply Flow	0 - 1	Write Only
IP-Address	Valve IP on LAN		Read Only
DeltaT Limit	0 = Disabled, 1 = dT-Manager, 2 = dT-Manager Scaling	0 - 2	Write Only
SpDeltaT	Delta T Limiting Valve	2 – 100 F	Write Only
SpFlowDeltaT	Flow Saturation Value	0 – 1000 GPM	Write Only
SensorStatus	0 = OK, 1 = Not OK, 2 = OK Air bubbles	0 - 2	Read Only
Glycol Concentration %	Glycol concentration % reported by the Energy Valve only shown if activated	0-100%	Read Only

Tech.Doc - 06/20 - Subject to change. © Belimo Aircontrols (USA), Inc.

Actuator Adaptation

The actuator adaptation button calibrates the input signal range (2-10V) to the actuator angle of rotation range by driving the actuator to the mechanical end stops. Completion of the cycle, the actuator will follow the current input signal. By default, the actuator will run the adaptation cycle after the first power up. Belimo recommends performing a manual adaptation to the actuator if the actuator has been replaced. The manual adaptation can be activated by pressing the translucent "Adaptation" LED button for three seconds.



Belimo Data Analysis Tool

Data Analysis Tool is used to analyze imported data from the "Web View Data Logging". The Data Analysis Tool can be downloaded from the Energy Valve web page (www.energyvalve.com).

- View power and delta T curves for different flows for a coil.
- View and diagnose system behavior based on delta T, flow, and power data collected for 13 months.
- Help in the continuous commissioning of the Energy Valve. It does this by suggesting optimized delta T and flow saturation set points to be configured in the Energy Valve.

Compatibility:

The Data Analysis Tool runs with Microsoft Excel. There are two versions of the data analysis tool available. Please select the correct version to match the version of Excel you are running.

- Data analysis tool 2003 version; to be used with Microsoft Excel 2003 only.
- Data analysis tool 2007_2010 version; to be used with Microsoft Excel 2007 and 2010.

Constant Commissioning of the Energy Valve:

This tool can be used to constantly commission the Energy Valve.

Note: Keep a record of settings changes with date and time. This data can serve as a coil performance or maintenance record.

To use the Data Analysis Tool, the Energy Valve needs to collect data for a period that will represent full or close to full coil saturation. Use the following steps to import the data into the tool:

- Download the coil data (CSV files) from the Energy Valve's Web View to your computer.
- Import the .csv files in to the Data Analysis Tool. Multiple files can be imported at once.
- Select the Delta T Determination tab. Then, click the Calculate button to determine the optimized Delta T and Flow Saturation set points if the coil data shows close to saturation.
- Log onto the Energy Valve Web View. Enter the delta T Setpoint (Delta T Limit Value) and Flow Saturation (Flow Saturation Limit Value) set points in the Web View Setting page.

Belimo recommends performing this commissioning at least once annually to maximize system energy efficiency.

Downloading Coil Data from Web View

- Select time frame for exporting data
- Short Term data is captured every 30 seconds.
- Long Term data is captured for a period of 15 minutes and up to 2 hours.
- Data can be directly imported into data analysis tool. Files export in .csv format.

Data Logging

File Type

- Short term storage (31 Days uncompressed)
- Long term storage (13 Months compressed)

File Name

Default Datalog Configuration-2014-02-24.csv
 Default Datalog Configuration-2014-02-25.csv
 Default Datalog Configuration-2014-02-26.csv
 Default Datalog Configuration-2014-02-27.csv
 Default Datalog Configuration-2014-02-28.csv
 Default Datalog Configuration-2014-03-01.csv
 Default Datalog Configuration-2014-03-02.csv
 Default Datalog Configuration-2014-03-03.csv

Download

Erase Data Log

Delta T Determination

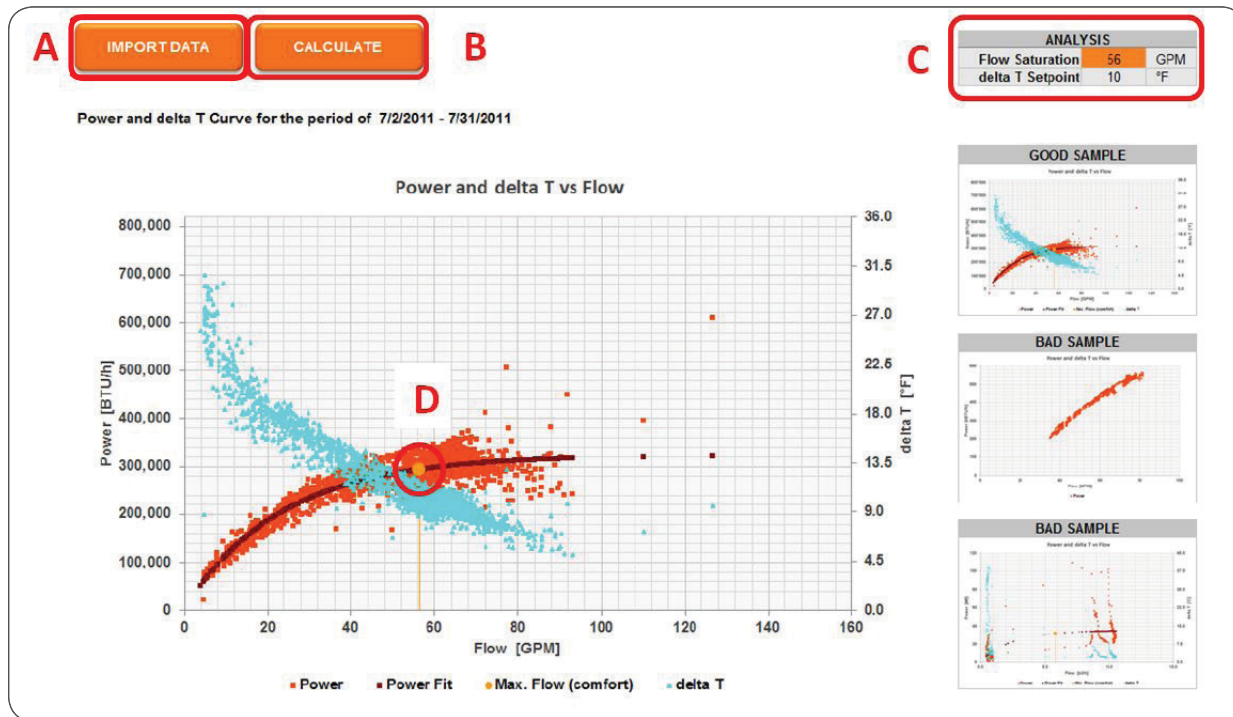

- Click to import Data Logging files generated by the Energy Valve Web View.
- Click to calculate the optimum delta T and flow saturation for the coil.
- Delta T Setpoint and Flow Saturation are calculated based on the provided data. These values are then entered into the Energy Valve Web View Settings area. The new settings will provide optimized delta T performance.
- Flow saturation point.

Problem	Field Observations	Possible Solution
Actuator will not move.	Actuator green LED is not on or flashing.	Verify the power supply and control signal are wired and operating correctly. If the actuator wiring is correct and the Green LED is not blinking the actuator has failed. Note: the LED is solid green while booting up.
	Actuator green LED is flashing but the valve will not move.	Valve may have debris. Depress the black gear release button on the side of the actuator and use the override handle to clear any debris that may have clogged the valve. If the valve does not move, then remove the actuator from valve and try to manually operate the valve stem.
Actuator does not modulate with the control signal as expected.	Valve throttles to either full open or closed.	Verify the hydronic circuit is filled, water is flowing, and isolation valves are opened. When Mode of Control is set to Flow or Power, any control signal greater than 0.5 or 2 VDC means there is a flow command. The flow or power logic will open the valve to satisfy the demand. Delta T Manager may be active.
Valve is yielding low flow but cannot be commanded to the full flow setting.	Valve is partially open but will not move to a full open position with a full signal command.	If the Delta T Manager is enabled it may be regulating the ΔT . Disable Delta T Manager until the chiller or boiler is operating correctly.
Flow is lower than expected.	Example: 50% flow signal is yielding 20% flow.	If equal percentage is the setting for the Control Signal Characteristic this is normal. For a correlation between flow and input signal, see the Equal Percentage Flow table on page 41.
Requested flow cannot be reached; actual flow is lower than commanded flow.	Valve is full open.	If the valve is fully open and flow feedback is 5% lower than flow set point this event is captured in the Status Summary in Web View. Increase the pump differential pressure to resolve low flow problems.
Flow measurements are not stable.	Air may be in the system.	Check for air in the system. Remove air from the system to solve the problem.
Flow Control, Power Control, and dT Manager Scaling are not working.	Flow calculation is 0 GPM.	See any flow error listed on the Status area of the Web View or use the ZTH US.
Temperature sensor does not work.	Web View Indication: -15°F > Temp. > 300°F -26°C > Temp. > 149°C	Remove remote sensor wires from the terminals and verify resistance with an ohm meter, replace if damaged. Below are typical PT 1000 readings: 176°F [80°C] = 1347 ohms 68°F [20°C] = 1078 ohms 50°F [10°C] = 1039 ohms
ZTH: Sensor status not OK	Web View status page: Flow Sensor Error Counter > 0	Check flow sensor to see if it is reading flow when valve is open. If it is not, contact Technical Support.
Device running slow when viewed in BACnet front end.	Device busy or slow.	Reduce the number of points being pulled in BACnet system and or reduce the polling rate.
Valve does not respond to analog control signal.	2-10 analog signal is modulated but the actuator does not respond.	Once Object SpRel has been written to via BACnet the valve will no longer respond to analog signal. The only way to restore the valve responding to the analog control signal is to power cycle the actuator.
Flow Sensor does not work properly.	For 2½" through 6" - Flow sensor reading is below 3mA or higher than 20.5mA. For ½" through 2" - Error byte communicates failure status.	Replace sensor.

Flow Reduction Chart

MAXIMUM FLOW BASED ON MINIMUM DIFFERENTIAL PRESSURE FOR ANSI 125 NPT MODELS

Size		8 psi	5 psi*	4 psi	3 psi	2 psi	1 psi
Inches	DN [mm]						
½	15	5.5 GPM	5.5 GPM	5.5 GPM	5.5 GPM	4.8 GPM	3.4 GPM
¾	20	10.3 GPM	10.3 GPM	10.3 GPM	9.9 GPM	8.1 GPM	5.7 GPM
1	25	18.2 GPM	18.2 GPM	18.2 GPM	17.2 GPM	14.1 GPM	9.9 GPM
1¼	32	28.5 GPM	28.5 GPM	28.5 GPM	28.5 GPM	23.3 GPM	16.5 GPM
1½	40	39.6 GPM	39.6 GPM	39.6 GPM	39.6 GPM	34.9 GPM	24.7 GPM
2	50	100 GPM**	76.1 GPM	74 GPM	64.1 GPM	52.3 GPM	37 GPM
2½	65	127 GPM	127 GPM	93 GPM	81 GPM	66 GPM	47 GPM
3	80	180 GPM	180 GPM	138 GPM	120 GPM	97 GPM	69 GPM
4	100	317 GPM	317 GPM	235 GPM	203 GPM	166 GPM	117 GPM
5	125	495 GPM	495 GPM	367 GPM	318 GPM	260 GPM	183 GPM
6	150	713 GPM	713 GPM	550 GPM	476 GPM	389 GPM	275 GPM

* Select valve based on a minimum of 5 PSI differential.

** Applies to 2" EPIV models P2200S-800 through P2200S-1000 only.

MAXIMUM FLOW BASED ON MINIMUM DIFFERENTIAL PRESSURE FOR ANSI 250 FLANGED MODELS

Size		7.5 psi***	5 psi	4 psi	3 psi	2 psi	1 psi
Inches	DN [mm]						
2½	65	127 GPM	109 GPM	98 GPM	85 GPM	69 GPM	49 GPM
3	80	180 GPM	153 GPM	137 GPM	118 GPM	97 GPM	68 GPM
4	100	317 GPM	280 GPM	251 GPM	217 GPM	177 GPM	125 GPM
5	125	495 GPM	436 GPM	390 GPM	337 GPM	275 GPM	195 GPM
6	150	713 GPM	593 GPM	531 GPM	460 GPM	375 GPM	265 GPM

*** Select valve based on a minimum of 7.5 PSI differential.

Input Signal Scaling

FLOW CONTROL: EQUAL PERCENTAGE FLOW RESPONSE TO INPUT SIGNAL (V)

0.5-10 VDC Signal	2-10 VDC Signal	Water Flow in % of V'max
0.5	2	0%
3.16	4.24	10%
5.25	6	20%
6.49	7.04	30%
7.29	7.72	40%
7.95	8.28	50%
8.48	8.72	60%
8.96	9.12	70%
9.34	9.44	80%
9.66	9.73	90%
10	10	100%

POWER CONTROL: LINEAR POWER RESPONSE OR FLOW CONTROL: LINEAR FLOW RESPONSE TO INPUT SIGNAL (V)

0.5-10 VDC Signal	2-10 VDC Signal	Power in % of P'max or Water Flow in % of V'max
0.5	2	0%
1.45	2.8	10%
2.40	3.60	20%
3.35	4.40	30%
4.30	5.20	40%
5.25	6	50%
6.20	6.80	60%
7.15	7.60	70%
8.10	8.40	80%
9.05	9.20	90%
10	10	100%

Energy Valve

BACnet



BACnet Protocol Implementation Conformance Statement

Date: February 24, 2017

Vendor ID: 423

Vendor Name: BELIMO Automation AG

Product Name: P.W..EV-BAC

Product Model Number: N/A

Application Software Version: 3.01-0000 Firmware Revision: 12.25 BACnet Protocol Revision: 1.12

Product Description:

The device is an electronic pressure independent characterized control valve (CCV) with adjustable flow rate, sensor-operated flow control and monitoring of power and energy. The set-point, configuration parameters and feedback values are communicated via BACnet/IP or BACnet MS/TP.

The commissioning of the device (BACnet Device Address, IP Address settings, Foreign Device settings, MS/TP) is done via the integrated web-server.

BACnet Standardized Device Profile (Annex L):

BACnet Application Specific Controller (B-ASC)

List all BACnet Interoperability Building Blocks Supported (Annex K): Data Sharing - ReadProperty-B (DS-RP-B)

Data Sharing - ReadPropertyMultiple-B (DS-RPM-B)

Data Sharing - ReadProperty-B (DS-RP-B)

Data Sharing - WriteProperty-B (DS-WP-B)

Data Sharing - COV-B (DS-COV-B)

Device Management - DynamicDeviceBinding-B (DM-DDB-B)

Device Management - DynamicObjectBinding-B (DM-DOB-B)

Device Management - DeviceCommunicationControl-B (DM-DCC-B)

Segmentation Capability: No

Standard Object Types Supported:

BACnet Protocol Implementation Conformance Statement Continued

Data Link Layer Options:

BACnet IP, (Annex J)

BACnet IP, (Annex J), Foreign Device

MS/TP master (Clause 9), baud rate(s): 115K,76.8K, 38.4K,19.2K,9.6K

Device Address Binding:

Is static device binding supported? (This is currently necessary for two-way communication with MS/TP slaves and certain other devices.)

Yes No

Networking Options:

BACnet/IP Broadcast Management Device (BBMD)

Character Sets Supported:

ISO 10646 (UTF-8)

¹ Only if object commandable

• The properties Object_Name and Location of the Device Object support up to 255 characters (all other character strings are read-only).

• The device does not support the CreateObject and DeleteObject service.

• The writable Present_Value of Value objects may be changed in different ways: web page, service tool and BACnet service.

The value stored in the Present_Value represents the last value written via BACnet and doesn't reflect the actual setting in use.

Service processing

• The device supports DeviceCommunicationControl service. No password is required.



Object Name	Object Type /Instance	Description	Values	Default	Capability
<i>Device_Name</i>	<i>Device [x]</i>				
SpSource	Multi-state Value [122]	Setpoint Source The actuator has the possibility to be controlled from an analog input and at the same time being intergrated in BACnet (for monitoring). Depending on this setting the setpoint by bus or analog is valid. Analog: Setpoint from analog signal 0.5...10V on wire 3. Bus: Setpoint from BACnet AO [1]	Analog Bus	Analog	Read/Write
Override	Multi-state Output [1]	Override Control	1- Auto 2- Close 3- Open 4- V'nom 5- V'max 6- MotStop 7- P'nom 8- P'max	Auto	Read/Write
RelPos	Analog Input [1]	Relative Postion in %	0...100	-	Read Only
GlycolConcentr	Analog Input [60]	Glycol Concentration in % . If measurement is locked will display a constant value -1	0...100	-	Read Only
AbsPos	Analog Input [2]	Absolute Position in °	0...90	-	Read Only
SpPosReached	Binary Input [1]	Setpoint Position reached	No Yes	-	Read Only
DeltaTMgrStatus	Multi-state Input [102]	Delta T Manager Status	1- Not Selected 2- Standby 3- Active 4- Scaling standby 5- Scaling Active	-	Read Only
RelFlow	Analog Input [10]	Relative Flow in %	0...100	-	Read Only
AbsFlow_SI1	Analog Input [11]	Absolute Flow in l/min	0...100,000	-	Read Only
AbsFlow_SI2	Analog Input [12]	Absolute Flow in m3/h	0...600	-	Read Only
AbsFlow_SI3	Analog Input [14]	Absolute Flow in l/s	0...100,000	-	Read Only
AbsFlow_SI4	Analog Input [15]	Absolute Flow in l/h	0...100,000	-	Read Only
AbsFlow_US	Analog Input [13]	Absolute Flow in gpm	0...100,000	-	Read Only
SpAbsFlow_Is	Analog Input [114]	Setpoint Absolute Flow in l/s	0...100,000	-	Read Only
SpAbsFlow_lmin	Analog Input [111]	Setpoint Absolute Flow in l/min	0...100,000	-	Read Only
SpAbsFlow_lh	Analog Input [115]	Setpoint Absolute Flow in l/h	0...600	-	Read Only
SpAbsFlow_m3h	Analog Input [112]	Setpoint Absolute Flow in m3/h	0...600	-	Read Only
SpAbsFlow_gpm	Analog Input [113]	Setpoint Absolute Flow in gpm	0...100,000	-	Read Only
SpAnalog_V	Analog Input [5]	Setpoint Analog in Volt	0...10.00	-	Read Only
T1_SI	Analog Input [20]	Temperature 1 (remote) in °C	-10...+120	-	Read Only
T1_US	Analog Input [25]	Temperature 1 (remote) in °F	14...248	-	Read Only
T2_SI	Analog Input [21]	Temperature 2 (embedded) in °C	-10...+120	-	Read Only
T2_US	Analog Input [26]	Temperature 2 (embedded) in °F	14...248	-	Read Only
DeltaT_K	Analog Input [22]	Delta Temperature in K	0...+500	-	Read Only
DeltaT_US	Analog Input [27]	Delta Temperature in °F	-500...+500	-	Read Only
RelPower	Analog Input [40]	Relative Power in %	0...300	-	Read Only
AbsPower_SI	Analog Input [30]	Power in kW	0...2.147e+9	-	Read Only
AbsPower_US1	Analog Input [35]	Power in kBTU/h	0...2.147e+9	-	Read Only

Tech.Doc - 06/20 - Subject to change. © Belimo Aircontrols (USA), Inc.

Energy Valve

BACnet Object Description List



Object Name	Object Type /Instance	Description	Values	Default	Capability
AbsPower_US2	Analog Input [45]	Power in RT	0...2.147e+9	-	Read Only
E_Cooling_SI	Analog Input [31]	Cooling Energy in kWh	0...2.147e+9	-	Read Only
E_Cooling_US1	Analog Input [36]	Cooling Energy in kBTU	0...2.147e+9	-	Read Only
E_Cooling_US2	Analog Input [46]	Cooling Energy in ton·h	0...2.147e+9	-	Read Only
E_Cooling_US3	Analog Input [33]	Cooling Energy in MJ	0...2.147e+9	-	Read Only
E_Heating_US3	Analog Input [34]	Heating Energy in MJ	0...2.147e+9	-	Read Only
E_Heating_SI	Analog Input [32]	Heating Energy in kWh	0...2.147e+9	-	Read Only
E_Heating_US1	Analog Input [37]	Heating Energy in kBTU	0...2.147e+9	-	Read Only
E_Heating_US2	Analog Input [47]	Heating Energy in ton·h	0...2.147e+9	-	Read Only
Vmax	Analog Value [100]	Maximum Flow Limit in %	0...100	100	Write Only
Vmax_SI	Analog Value [90]	Maximum Flow Limit in l/min	0...4000	-	Write Only
Vmax_US	Analog Value [91]	Maximum Flow Limit in gpm	0...1000	-	Write Only
Vnom_SI	Analog Value [101]	Nominal Volume Flow in l/min (read-only)	0...100,000	-	Read Only
Vnom_US	Analog Value [102]	Nominal Volume Flow in gpm (read-only)	0...100,000	-	Read Only
Pmax	Analog Value [105]	Maximum Power Limit in %	0...100	100	Write Only
Pmax_SI	Analog Value [95]	Maximum Power Limit in kW	0...5000	-	Write Only
Pmax_US	Analog Value [96]	Maximum Power Limit in kBTU/h	0...15,000	-	Write Only
Pnom_SI	Analog Value [106]	Nominal Power Limit in kW (read-only)	0...2.147e+9	-	Read Only
Pnom_US	Analog Value [107]	Nominal Power Limit in kBTU/h (read-only)	0...2.147e+9	-	Read Only
ControlMode	Multi-state Value [100]	Control Mode The value defines the interpretation of the setpoint.	1- PosCtrl 2- FlowCtrl 3- PowerCtrl	FlowCtrl	Read/Write
DeltaT_Limitation	Multi-state Value [101]	Delta T Limitation	1- Disabled 2- dT-Manager 3- dT-Mgr scaling	Disabled	Read/Write
SpDeltaT_K	Analog Value [103]	Setpoint DeltaT in K	256...311	4	Write Only
SpDeltaT_US	Analog Value [104]	Setpoint DeltaT in °F	2...100	7	Write Only
SpFlow_DeltaT_SI	Analog Value [108]	Setpoint Flow at DeltaT in l/min (Flow saturation value)	0...4000	0	Write Only
SpFlow_DeltaT_US	Analog Value [109]	Setpoint Flow at DeltaT in gpm (Flow saturation value)	0...1000	0	Write Only
ErrorState	Analog Input [100]	Error State	see table below	-	Read Only
RstErrCount	Binary Value [100]	Reset Error Counters	None Reset	None	Read/Write
SummaryStatus	BI [101]	Summary Status Summarizes all status from MI 103 - 107	OK Not OK	-	R
StatusSensor	MI [103]	Status Sensor Indicates informations within the flow sensor and both temperature sensors	OK Flow Sensor not OK T1 not OK T2 not OK	-	R
StatusFlow	MI [104]	Status Flow Setpoint cannot be reached within 3 min during flow control Flow is measured but position of valve is closed Reverse flow is detected	OK Reverse flow detected Flow not reached Flow in closed position	-	R
StatusMedia	MI [105]	Status Media Airbubbles in the hydronic system	OK Airbubbles Freeze warning	-	R

Tech.Doc - 06/20 - Subject to change. © Belimo Aircontrols (USA), Inc.

Object Name	Object Type /Instance	Description	Values	Default	Capability
StatusActuator	MI [106]	Status Actuator Mechanical overload due to blocked valve, etc. Gear disengaged button pressed	OK Actuator cannot move Gear disengaged	-	R
StatusPower	MI [107]	Status Power Setpoint cannot be reached within 3 min during power control	OK Power not reached	-	R
SpRel	Analog Output [1]	Setpoint Relative in % The set point is related either to the position, the flow (Vmax) or the power (Pmax). See ControlMode for more information.	0...100	0	Read/Write

Error State Translation

Bit 0:	(1)	Error Sensor T1
Bit 1:	(2)	Error Sensor T2
Bit 2:	(4)	Error Flow Sensor
Bit 3:	(8)	Actuator cannot move
Bit 4:	(16)	Flow with closed valve
Bit 5:	(32)	Air bubbles
Bit 6:	(64)	Flow not reached
Bit 7:	(128)	Power not realized
Bit 8:	(256)	Gear disengaged
Bit 9:	(512)	Reverse Flow Detected

Example: "Flow not reached" + "Gear disengaged" = 64 + 256 = 320

Energy Valve -Modbus Description

Modbus General Notes

General information	Protocol:	Modbus RTU / RS-485
	Number of nodes:	Max. 32 (without repeater)
	Transmission formats:	1-8-N-2, 1-8-N-1, 1-8-E-1, 1-8-O-1, <i>Default: 1-8-N-2</i>
	Baud rate:	9,600, 19,200, 38,400, 76,800, <i>Default: 38,400 Baud 115,200 Baud</i>
	Terminating resistor:	120 Ω (to be done with external resistor)
	Parameterization:	through the integrated web server
Register implementation	All data is arranged in a table and addressed by 1..n (register) or 0..n-1 (address). No distinction is made between data types (Discrete Inputs, Coils, Input Registers and Holding Registers). As a consequence, all data can be accessed with the two commands for Holding Register. The commands for Discrete Inputs and Input Registers can be used as an alternative.	
Standard commands	Read Holding Registers [3] Write Single Register [6] Read Discrete Inputs [2] Read Input Registers [4] Write Multiple Registers [16]	

Command "Read Discrete Inputs"	The command reads one or more bits and can alternatively be used for Register No. 105 (Malfunction and Service information). Example: The start address to be used is 1664 104 (Register Address) * 16 (Bit) = 1664						
Interpret values in the registers	All values in the register are unsigned integer with exception of Register No. 17/19/22. Signed integers are represented as two's complement. Example unsigned integer: Read (Function 03, 1 Register) Value Register No. 12 = $0001'1010'1100'1000_2 = 6,856_{10}$ Actual Value = Value * Scaling factor * Unit = $6,856 * 0.01 * \text{m}^3/\text{h} = 68.56 \text{ m}^3/\text{h}$ Example signed integer Read (Function 03, 1 Register) Value Register No. 17 = $1111'1101'1111'0010_2 = -526_{10}$ Actual Value = Value * Scaling factor * Unit = $-526 * 0.01 * \text{°C} = -5.26 \text{ °C}$						
32-Bit Values in two registers	Values that exceed 65,535 are stored in two consecutive Registers and have to be interpreted as "little endian" / LSW (Least Significant Word) first. Example: Register No. 10 (AbsFlow LowByte) = $14,551_{10} = 0011'1000'1101'0111_2$ Register No. 11 (AbsFlow HighByte) = $19_{10} = 0000'0000'0001'0011_2$ → AbsFlow = $0000'0000'0001'0011'0011'1000'1101'0111_2 = 1,259,735_{10}$ = 1259.735 l/h						
	<table border="1"> <tr> <td>AbsFlow High Byte</td> <td>AbsFlow Low Byte</td> </tr> <tr> <td>19</td> <td>14,551</td> </tr> <tr> <td>0000'0000'0001'0011</td> <td>0011'1000'1101'0111</td> </tr> </table>	AbsFlow High Byte	AbsFlow Low Byte	19	14,551	0000'0000'0001'0011	0011'1000'1101'0111
AbsFlow High Byte	AbsFlow Low Byte						
19	14,551						
0000'0000'0001'0011	0011'1000'1101'0111						
	<p>Math formula:</p> <p>AbsFlow = (AbsFlow HighByte * 65,536) + AbsFlow LowByte</p> <p>AbsFlow = (19 * 65,536) + 14,551 = 1,259,735 = 1259.735 l/h</p>						

Modbus Overview

Number	Address	Register	R/W
1	0	Setpoint [%]	R/W
2	1	Override control	R/W
3	2	-	R
4	3	Actuator type	R
5	4	Relative position [%]	R
6	5	Absolute position [°]	R
7	6	Relative Flow [%]	R
8	7	Absolute flow [UnitSel]	LData
9	8		HData
10	9	Absolute flow [l/s]	LData
11	10		HData
12	11	Absolute flow [gpm]	LData
13	12		HData

Modbus Overview Continuation

Number	Address	Register		R/W
14	13	Setpoint Absolute Flow [UnitSel]	LData	R
15	14		HData	
16	15	Setpoint Analog [V]		R
17	16	Temperature 1 [°C]		R
18	17	Temperature 1 [°F]		R
19	18	Temperature 2 [°C]		R
20	19	Temperature 2 [°F]		R
21	20	Delta Temperature [K]		R
22	21	Delta Temperature [°F]		R
23	22	Glycol Concentration [%]		R
24	23	Relative power [%]		R
25	24	Absolute Power [UnitSel]	LData	R
26	25		HData	
27	26	Absolute Power [kW]	LData	R
28	27		HData	
29	28	Absolute Power [kBtu/h]	LData	R
30	29		HData	
31	30	Energy Cooling [UnitSel]	LData	R
32	31		HData	
33	32	Energy Cooling [kWh]	LData	R
34	33		HData	
35	34	Energy Cooling [kBtu]	LData	R
36	35		HData	
37	36	Energy Heating [UnitSel]	LData	R
38	37		HData	
39	38	Energy Heating [kWh]	LData	R
40	39		HData	
41	40	Energy Heating [kBtu]	LData	R
42	41		HData	
101	100	Series number 1st part		R
102	101	Series number 2nd part		
103	102	Series number 4th part		
104	103	Firmware version		R
105	104	Malfunction & Service information		R
106	105	Vmax [%]		R/W
107	106	Absolute Vmax [l/s]	LData	R/W
108	107		HData	

Modbus Overview Continuation

Number	Address	Register	R/W
109	108	Absolute Vmax [gpm]	LData
110	109		HData
111	110	Absolute Vnom [UnitSel]	R
112	111		HData
113	112	Absolute Vnom [l/s]	R
114	113		HData
115	114	Absolute Vnom [gpm]	R
116	115		HData
117	116	Pmax [%]	R/W
118	117	Absolute Pmax [kW]	R/W
119	118		HData
120	119	Absolute Pmax [kBTU/h]	R/W
121	120		HData
122	121	Absolute Pnom [UnitSel]	R
123	122		HData
124	123	Absolute Pnom [kW]	R
125	124		HData
126	125	Absolute Pnom [kBTU/h]	R
127	126		HData
128	127	-	R
129	128	-	R
130	129	-	R
131	130	DeltaT Limitation [K]	R/W
132	131	DeltaT Manager Status	R
133	132	Setpoint DeltaT [K]	R/W
134	133	Setpoint DeltaT [°F]	R/W
135	134	Setpoint Flow at DeltaT [l/s]	R/W
136	135		HData
137	136	Setpoint Flow at DeltaT [gpm]	R/W
138	137		HData
139	138	-	R
140	139	-	R
141	140	Control Mode	R/W
142	141	Unit Selection Flow	R/W
143	142	Unit Selection Power	R/W
144	143	Unit Selection Energy	R/W
145	144	Setpoint Source	R/W

Tech.Doc - 06/20 - Subject to change. © Belimo Aircontrols (USA), Inc.

Modbus Registers/Address

Modbus Object Name	Register Number	Register Address	Description	Values	Default	Capability	Scale
Setpoint [%]	1	0	Setpoint Relative in % The setpoint is related either to the position, the flow (vMax) or the power (Pmax). See Control mode for more information.	0...1000	0	Read/Write	0.01
Setpoint Source	145	144	The actuator has the possibility to be controlled from an analog input even when integrated through BACnet. Depending on this setting the setpoint by bus or analog will be followed. Analog: Setpoint from analog signal 0...10V on wire 3 Bus: Setpoint from BACnet, register Number 1	0- Analog, 1-Bus	0	Read/Write	
Override	2	1	Override Control	1- Auto	Auto	Read/Write	
				2- Close			
				3- Open			
				4- V' nom			
				5- V' max			
				6- Motor Stop			
				7- P'nom			
				8- P'max			
Relative Position [%]	5	4	Relative Position in %	0...100	-	Read Only	0.01
Absolute Position [°]	6	5	Absolute Position in °	0...90	-	Read Only	0.01
DeltaT_Mgr_Status	132	131	Delta T Manager Status	0- Not Selected	0- Not Selected	Read Only	
				1- Standby			
				2- Active			
				3- Scaling Standby			
				4- Scaling Active			
Relative Flow [%]	7	6	Relative Flow in %	0...100	0	Read Only	0.01
Absolute Flow [UnitSel]	8/9	7/8	Absolute Flow Unit select related to unit in Register 142	0...100,000		Read Only	
Absolute Flow [l/s]	10/11	9/10	Absolute Flow in l/s	0...100,000	-	Read Only	0.001
Absolute Flow [gpm]	12/13	11/12	Absolute Flow in gpm	0...100,000	-	Read Only	0.001
Setpoint Absolute Flow [UnitSel]	14/15	13/14	Setpoint Absolute Flow Unit select related to unit in Register 142		-	Read Only	0.001

Tech.Doc - 06/20 - Subject to change. © Belimo Aircontrols (USA), Inc.

Modbus Object Name	Register Number	Register Address	Description	Values	Default	Capability	Scale
Set point Analog [V]	16	15	Setpoint Analog in Volt	0.000...10.00V	-	Read Only	
Temperature 1 [°C]	17	16	Temperature 1 (remote) in °C	-10...+120	-	Read Only	0.01
Temperature 1 [°F]	18	17	Temperature 1 (remote) in °F	14...248	-	Read Only	0.01
Temperature 2 [°C]	19	18	Temperature 2 (embedded) in °C	-10...+120	-	Read Only	0.01
Temperature 2 [°F]	20	19	Temperature 2 (embedded) in °F	14...248	-	Read Only	0.01
Delta Temperature °C	21	20	Delta Temperature in °C	-500...+500	-	Read Only	0.01
Delta Temperature °F	22	21	Delta Temperature in °F	-500...+500	-	Read Only	0.01
Glycol Concentration [%]	23	22	Glycol Concentration in %	0...100	-	Read Only	0.01
Relative Power [%]	24	23	Relative Power in %	0...100	-	Read Only	0.01
Absolute Power [UnitSel]	25/26	24/25	Absolute Power for Unit Selected in Power Register 143		-	Read Only	0.001
Absolute Power [kW]	27/28	26/27	Power in kW	0...2.147e+9	-	Read Only	0.001
Absolute Power [kBTU/h]	29/30	28/29	Power in kBTU/h	0...2.147e+9	-	Read Only	0.001
Energy Cooling [UnitSel]	31/32	30/31	Cooling Energy unit which is selected in Register 144		-	Read Only	1
Energy Cooling [kWh]	33/34	32/33	Cooling Energy in kWh	0...2.147e+9	-	Read Only	1
Energy Cooling [kBTU]	35/36	34/35	Cooling Energy in kBTU	0...2.147e+9	-	Read Only	1
Energy Heating [UnitSel]	37/38	36/37	Heating Energy unit which is selected in Register 144		-	Read Only	1
Energy Heating [kWh]	39/40	38/39	Heating Energy in kWh	0...2.147e+9	-	Read Only	1
Energy Heating [kBTU]	41/42	40/41	Heating Energy in MJ	0...2.147e+9	-	Read Only	1
Vmax [%]	106	105	Maximum Flow Limit in %	0...100	100	Read/Write	0.01
Vmax [l/s]	107/108	106/107	Maximum Flow Limit in l/s	0...4000	-	Read/Write	0.001
Vmax [gpm]	109/110	108/109	Maximum Flow Limit in gpm	0...1000	-	Read/Write	0.001
Vnom [UnitSel]	111/112	110/111	Nominal volume which is selected in Register 142		-	Read Only	0.001
Vnom [l/s]	113/114	112/113	Nominal Volume in l/min	0...100,000	-	Read Only	0.001
Vnom [gpm]	115/116	114/115	Nominal Volume in gpm	0...100,000	-	Read Only	0.001

Modbus Object Name	Register Number	Register Address	Description	Values	Default	Capability	Scale
Pmax [%]	117	116	Maximum Power Limit in %	0...100	100	Read/Write	0.01
Pmax [kW]	118/119	117/118	Maximum Power Limit in kW	0...5000	-	Read/Write	0.001
Pmax [kBTU/h]	120/121	119/120	Maximum Power Limit in kBTU/h	0...15,000	-	Read/Write	0.1
Pnom [UnitSel]	122/123	121/122	Nominal Power Unit which is selected in Register 143		-	Read Only	0.001
Pnom [kW]	124/125	123/124	Nominal Power in kW	0...2.147e+9	-	Read Only	0.001
Pnom [kBTU/h]	126/127	125/126	Nominal Power in kBTU/h	0...2.147e+9	-	Read Only	0.001
ControlMode	141	140	The value defines the interpretation of the setpoint	0- PosCtrl	Flow-Ctrl	Read/Write	1
				1- FlowCtrl			
				2- PowerCtrl			
DeltaT_ Limitation	131	130	Delta T Limitation	0- Disabled (off)	Dis-abled	Read/Write	1
				1- dT- Manager			
				2- dT Manager Scaling			
Set point DeltaT [K]	133	132	Setpoint Delta T in K	0...+500	4	Read/Write	0.01
Set point DeltaT [°F]	134	133	Setpoint Delta T in °F	2...100	10	Read/Write	0.01
Set point Flow_ DeltaT [l/s]	135/136	134/135	Setpoint Flow at Delta T in l/s (Flow saturation value)	0...4000	0	Read/Write	0.001
Set point Flow_ DeltaT [gpm]	137/138	136/137	Setpoint Flow at Delta T in gpm (Flow saturation value)	0...1000	0	Read/Write	0.001
Unit Select Flow	142	141	Selection of flow Unit Defines Registers 8/9, 14/15, 111/112	0- m3/s	gpm	Read/Write	
				1- m3/h			
				2- l/s			
				3- l/min			
				4- l/h			
				5- gpm			
Unit Select Power	143	142	Selection of Power unit defines unit Register No. 25/26, 122/123	0- W	kBTU/h	Read/Write	
				1- kW			
				2- BTU/h			
				3- kBTU/h			
				4- Tons			
Unit Select Energy	144	143	Selection of Energy unit defines unit Register No. 31/32, 37/38	0- J	kBTU	Read/Write	
				1- kWh			
				2- MWh			
				3- kBTU			
				4- tonh			
				5- MJ			
6- GJ							
ErrorState	105	104	Error State				

Tech.Doc - 06/20 - Subject to change. © Belimo Aircontrols (USA), Inc.

Energy Valve

Terms and Conditions of Sale and Warranty



I. General

1.1. The following Terms and Conditions of Sale and Warranty ("Terms") apply to the sale of products described in this Product Guide and products sold by Seller as an original equipment manufacturer ("OEM") which may not be included in this Product Guide ("Product" or "Products"). As used herein, "Seller" or "Belimo" refers to Belimo Aircontrols (USA), Inc., or Belimo Aircontrols (CAN), Inc., or Belimo Automation AG, or Belimo Brasil - Comércio de Automação Ltda. as applicable, and "Client" refers to the individual or business entity that purchases the Products directly from Seller. These Terms shall apply unless the Seller and Client mutually agree to different terms and memorialize such agreement in writing signed by both Client and Seller or (ii) unless Seller changes these Terms and publishes the Terms on its Website to be found at: www.belimo.us, in which case the most recent Terms published on the Website will prevail. In case Seller's delivery includes software and/or application software and accompanying documentation, the terms of the license agreement for such software and/or application software are applicable in addition to these Terms. However, in case of conflicts between the terms and conditions of the license agreement and the Terms, the terms and conditions of the license agreement shall prevail.

II. Price

2.1. The Seller's price for Products (the "Price") is net, F.O.B. Point of Origin, and is calculated in US currency for sales made by Belimo Aircontrols (USA), Inc., and calculated in Canadian currency for sales made by Belimo Aircontrols (CAN) Inc., and Brazilian currency for sales made by Belimo Automation AG or Belimo Brasil - Comércio de Automação Ltda. to Clients in Brazil.

2.2. The Price, unless otherwise agreed upon, does not include freight and packaging (wooden crates, pallets, etc.), the costs of which will be charged to Client at cost for each shipment and shall be payable with payment of the Price.

2.3. Orders for Products where the total order has a net value of less than US \$300 (CAN \$300) will be subject to a US \$20 (CAN \$20) handling fee (the "Handling Fee"). The Handling Fee will not be charged for orders of Products with a net value equal to or greater than US \$300 (CAN \$300) or for Products ordered through Seller's e-commerce ordering system at: www.belimo.us.

2.4. Seller reserves the right to make partial deliveries of orders of Products, each of which deliveries may be invoiced separately by Seller.

2.5. The Price does not include charges for wiring diagrams, installation, and commissioning, which will be charged to Client separately and will be payable on demand.

III. Payment

3.1. Invoices are payable in US currency for sales made by Belimo Aircontrols (USA), Inc., and in Canadian currency for sales made by Belimo Aircontrols (CAN); Inc., and in Brazilian currency for sales made by Belimo Automation AG on behalf of Brazil or Belimo Brasil - Comércio de Automação Ltda. Payments on invoices are due no later than 30 days from the date of invoice, without any deductions.

3.2. If Client maintains an outstanding balance for 45 days or more after the date of invoice, Client may be subject to restricted shipments of Products. A Client may also be required to pay for all future deliveries of Products on a cash-on-delivery only basis.

IV. Title and Risk

4.1. Title to Products will pass to Client from the Seller based upon the agreed Incoterms as stated on the Order Confirmation. The Seller retains the right to a return of the Product when payment is not received.

V. Damage or Loss in Transit

5.1. Seller assumes no liability for damage or loss of shipment of Products, which risk shall at all times remain with the carrier. All shipments must be unpacked and examined by Client immediately upon receipt. Any external evidence of loss or damage must be noted on the freight bill accompanying the shipment of Products or carrier's receipt and signed by the carrier's agent at the time of delivery. Failure to do so will result in the carrier's refusal to honor any claim relating to damage of Products. Client must also notify Seller within 5 days of such damage by providing Seller with a copy of the freight bill or damage report so that Seller can file a claim for loss or damage in transit with the carrier. If the damage does not become apparent until the shipment is unpacked, Client must make a request for inspection

by the carrier's agent and file with the carrier within 15 days after receipt of product and notify Seller of the same.

VI. Delivery

6.1. Seller undertakes to make every attempt to adhere to its stated delivery parameters and to make a timely delivery of the Products but does not guarantee any delivery specifications. Each contract entered into for the purchase of Products is not cancelable nor is Seller liable for any direct or indirect losses that may arise, for any reason whatsoever, due to Seller's failure to meet any stated or assumed delivery schedules.

VII. Inventory Overstock

7.1. If Client has an overstock of Product inventory, such Products received by Client cannot be returned unless and until: (i) Client alerts Seller that it intends to return some overstock of Products, (ii) Seller agrees to accept such return, (iii) Client obtains a Return Material Authorization ("RMA") number from Seller for such return of such Products, and (iv) Client follows all return instructions provided by the Seller. The RMA number must be clearly written on the outside of all packaging for any returned overstock of Products.

7.2. Only such Products returned in original packaging and shipped to Seller at Client's cost may be accepted for return under this Section. Client is also responsible for payment of a restocking charge for all returned overstocked Products in an amount no less than 20% of the invoice value of the Products ("Restocking Charges"). Any piping package or custom order returns carry a minimum restocking charge of 75% of the invoice value. Returns that result from Seller errors and not overstocking will be credited in full and will not be subject to Restocking Charges.

7.3. Any Product received damaged or showing evidence of having been installed will be refused or assessed a higher restocking charge.

7.4. If Client requests product to be returned to Client, the Client will be responsible for return shipping charges. See specific product literature for exclusions or exceptions.

7.5. Any products that are designed to a Client's unique specifications (e.g. retrofit) are not returnable.

VIII. Handling, Installation and Use of Products

8.1. Products are only intended for installation and commissioning by trained technicians.

8.2. The installation and exchange of Products may only be carried out by trained technicians. Products may only be handled by trained technicians and only in accordance with the most current valid data and installation sheets.

IX. Limited Warranty

A. 5-year Limited Warranty

9.1. Products that are designated by Seller as carrying a 5-year warranty to a location in the United States, Canada, or Latin America shall carry a 5-year warranty. The 5-year warranty is unconditional for the first two years from the date of sale of the Products to Client, subject to the Limitation On Warranty in Section 9C. After the first two years from the date of sale, the warranty coverage shall not apply to damage to Products not resulting from normal wear and tear (e.g. negligence, misuse, or failure to maintain). Product specific terms of warranty with regard to warranty period or conditions of warranty may apply to certain specified Products as stated in the documentation for those Products.

B. 2-year Conditional Warranty

9.2. Products that are designated by Seller as carrying a 2-year warranty to a location in the United States, Canada, or Latin America shall carry a 2-year warranty. The 2-year warranty is conditional from the date of sale of the Products to Client, and the warranty coverage shall not apply to damage to Products not resulting from normal wear and tear (e.g. negligence, misuse, or failure to maintain). Product specific terms of warranty with regard to warranty period or conditions of warranty may apply to certain specified Products as stated in the documentation for those Products.

C. Limitation On Warranty; Warranty Disclaimer

9.3. Seller's warranties hereunder shall be null and void in the event of any: (a) modification or unauthorized repairs of Products by Client; (b) unauthorized incorporation or integration of Products into or with Client's equipment; (c) use of Products in an unauthorized manner; or (d) damage to Products not caused by Seller.

9.4. These Terms constitute the entire understanding and agreement

between Seller and Client regarding the warranties that cover Products and supersedes all previous understandings, agreements, communications and representations. All Seller warranties are extended only to Client and are non-transferrable. All Seller warranties shall extend only to HVAC use of the Products. If Products are used in non-HVAC applications (e.g., aircraft, industrial processes, etc.), Seller's warranties will not cover such Products. Client will be solely responsible for any damage to or malfunction of Products or for any damage resulting from such use of Products.

9.5. Both the conditional and unconditional warranties hereunder cover the Products only, and do NOT cover labor associated with the troubleshooting, removal or replacement of such Products.

9.6. EXCEPT FOR THE EXPRESS WARRANTIES SPECIFIED IN SECTION IX, SELLER MAKES NO OTHER WARRANTIES, EITHER EXPRESS OR IMPLIED, AND DISCLAIMS ALL OTHER WARRANTIES, INCLUDING BUT NOT LIMITED TO THE IMPLIED WARRANTY OF FITNESS FOR A PARTICULAR PURPOSE AND IMPLIED WARRANTY OF MERCHANTABILITY.

D. Remedies

9.7. If a defect arises in the Product and an RMA is issued as provided in Section 9.8, Seller will, at its option and to the extent permitted by law, either (1) repair the Product at no charge, using new or refurbished replacement parts or (2) replace the Product with a new Product. In the event of such a defect, to the extent permitted by law, these are Client's sole and exclusive remedies.

9.8. Client cannot return Products to Seller unless: (i) Client notifies Seller that it intends to return such Products, (ii) Seller agrees to accept the return of such Products, (iii) Client obtains a RMA number from Seller for the return of such Products, and (iv) Client follows all return instructions provided by the Seller. Client shall promptly notify Seller of Products' alleged defect and provide Seller with other evidence and documentation reasonably requested by Seller. The RMA number must be clearly written on the outside of all packaging for any returned Products. Only Products returned to the proper location as instructed by Seller and identified with an RMA number will be considered for credit.

9.9. Returns that result from Seller's breach of these Terms will be credited in full and will not be subject to Restocking Charges.

9.10. Seller-authorized support technicians are available for troubleshooting before any shipments to Seller. The contact information for Belimo customer service is listed on the back page of Belimo's Product Guide and Price List ("PGPL") or may be found at www.belimo.us.

9.11. If Seller determines that a problem cannot be resolved without Product replacement, an RMA number will be issued by Seller for return of the Products. Prior to returning any Products under a warranty, Client must obtain an RMA number from Seller, along with shipping instructions for the return. The RMA number must be clearly written on the outside of the box containing the returned Products. Only Products returned to the proper location and identified with an RMA number will be accepted by the Seller.

9.12. All returned Products should be packaged appropriately to prevent further damage. Seller reserves the right to refuse any returned Product if improperly packaged or labeled (e.g. without an RMA number on the outside of packaging). Products returned without proper RMA documentation will void Seller's warranty. Seller is not responsible for charges that Client may incur as a result of the removal or replacement of Products.

9.13. Repaired or replacement Products are shipped from Seller via ground shipment. Other shipping methods are available at the sole expense of the Client.

9.14. Repaired, replaced or exchanged Products will carry a warranty for a period of time equal to the greater of: (i) the remainder of the original 5-year warranty or 2-year warranty that was applicable to the repaired, replaced or exchanged Products, or (ii) six months, effective from the date the repaired, exchanged or replaced Products are shipped by Seller (the "Replacement Warranty Period").

9.15. If Seller determines that Product under warranty is to be replaced, Seller may elect to send a replacement in advance of receiving the returned item. For valve products 2½" in diameter or greater, a purchase order is required. An invoice will be issued and shall be due and payable if the returned Products are not received by Seller within 60 days from the date that the replacement Products are shipped. Additional charges may apply if the nature of the problem has been misrepresented by Client.

9.16. New Products ordered in an attempt to circumvent the warranty

process may NOT be reimbursed if, upon receipt of returned Products, it is determined that the defect in the returned Products is actually field related, or the Products have been returned for cosmetic reasons only.

X. Liability Disclaimer

10.1. IN NO EVENT SHALL SELLER HAVE ANY LIABILITY TO CLIENT OR ANY THIRD PARTY FOR ANY (a) LOST PROFITS OR COSTS OF PROCUREMENT OF SUBSTITUTE GOODS OR SERVICES, OR FOR ANY INDIRECT, INCIDENTAL, SPECIAL OR CONSEQUENTIAL DAMAGES, OR (b) ANY DAMAGES WHATSOEVER RESULTING FROM THE PERFORMANCE OR A TEMPORARY OR PERMANENT LOSS OF USE OF PRODUCTS, HOWEVER CAUSED UNDER ANY THEORY OF LIABILITY AND WHETHER BASED IN CONTRACT, TORT (INCLUDING NEGLIGENCE), STATUTE OR OTHERWISE. THE FOREGOING LIMITATIONS SHALL APPLY EVEN IF SELLER HAS BEEN ADVISED OF THE POSSIBILITY OF SUCH DAMAGES AND NOTWITHSTANDING THE FAILURE OF ESSENTIAL PURPOSE OF ANY LIMITED REMEDY STATED HEREIN. SELLERS MAXIMUM AGGREGATE LIABILITY UNDER, ARISING FROM OR IN CONNECTION WITH THE SALE OF ITS PRODUCTS TO CLIENT, SHALL BE LIMITED TO THE AMOUNT PAID BY CLIENT FOR THE PRODUCT DEEMED RESPONSIBLE FOR THE LOSS OR DAMAGE.

10.2. Client releases Seller in full from any possible third party claims resulting in connection with the circumstances listed above. This also applies to claims in connection with products liability.

10.3. If Client becomes aware that any third party has made or appears likely to make any claim regarding Products (including, without limitation, regarding Product defects or rights infringed by Products), then Client shall immediately inform Seller and afford to Seller all assistance that Seller may require to enforce its rights and defend such claim.

XI. Proper Law and Jurisdiction

11.1. All sales of Products under these Terms described herein shall be governed by the laws of the State of Connecticut, without regard to its conflicts of law principles, and Seller and Client agree to submit to the exclusive jurisdiction of the federal and state courts located in the State of Connecticut with respect to any dispute arising from the subject matter hereof. The Seller and Client hereby waive all rights to a jury trial in connection with any claims relating to the subject matter hereof. All causes of action arising out of or connected to the sales of Products under these Terms shall be resolved individually, with no right by Seller or Client to participate in a representative capacity, or as a member of any class action.

XII. Privacy and Data

12.1 Seller places great value on the implementation of lawful data processing to protect Client's personal data. Seller is obliged to process Client's personal data in accordance with applicable law. Seller is dependent on the services of a third party for the provision of its services. Seller has obligated the third party to process Client's data only in connection with the services agreed with Seller, to ensure the same level of data protection as Seller, and to not pass on Client's data to other third parties without Client's consent. When processing Client's data and transferring Client's data to third parties, Seller will use reasonable commercial efforts to provide an appropriate level of data protection and that appropriate organizational and technical measures are implemented to protect Client's personal data. More detailed information on Seller's data protection guidelines is available from the following Internet address: www.belimo.com/privacy.

XIII. California Proposition 65



13.1 WARNING: Some Belimo Products can expose you to chemicals which are known to the State of California to cause cancer, birth defects, or other reproductive harm. Please refer to the Product specific Technical Data sheet at www.belimo.us for details.

For more information see www.p65warnings.ca.gov

Energy Valve

Glossary of Terms

ΔT

Measured differential temperature between water supply and return.

Analog

A linear signal from one device to another. It used to move or read values. It is used by a controller to modulate an actuator. Typical analog signal range is 2-10 VDC, 0-10 VDC, or 4-20 mA.

BACnet

A standard world-wide communication protocol that is used in building automation. BACnet uses two common communication mechanisms, BACnet IP which communicates over Ethernet networks. BACnet MS/TP communicates over 2 or 3-wire RS485 networks.

BMS (Building Management System)

A computer-based control system installed in buildings to control and monitor the building's mechanical and electrical equipment.

CCV (Characterized Control Valve)

A Belimo patented ball valve with characterizing disc that provides equal percentage flow characteristic with high rangeability, zero leakage, and high close-off.

DDC (Direct Digital Control)

A controller with software to operate control valves, dampers and other devices.

Delta T Limit Value

A setting used by the Delta T Manager to limit coil overflow.

Delta T Manager

A patented flow limiting logic applied to the Energy Valve Control Modes.

dT Manager

An option in the Delta T Manager logic that produces a fixed dT setpoint.

dT Manager Scaling

An option in the Delta T Manager logic that produces a variably scaled dT setpoint.

delta T (ΔT)

The difference in the supply and return temperatures of a coil.

dT setpoint

The set point used by the Delta T Manager logic. When used with dT Manager it is a fixed setting. When used with dT Manager Scaling it becomes a calculated variable over a scaled range.

Flow Saturation Limit Value / Flow Saturation

A setting used with dT Manager Scaling to reset the Delta T Limiting Value and create a variable, dT setpoint.

Ghost Energy

Leaky control valves can create ghost heating and cooling demand and excess ventilation, which comes with a need to dehumidify or preheat. Also, there is ghost pumping for the additional chilled water and heating water flows along with ghost heating and cooling. A 1% leakage creates a 5 to 10% loss of energy.

MP-Bus (MP)

A Belimo communication protocol. The ZTH US tool uses this protocol to view and change actuator settings.

P'max

The maximum thermal power setting.

P'nom

The maximum thermal power of the heat exchanger.

V'max

The maximum valve flow setting.

V'nom

The maximum valve flow.

Belimo Americas

USA, Latin America, and the Caribbean: www.belimo.us

Canada: www.belimo.ca, Brazil: www.belimo.com.br

Belimo Worldwide: www.belimo.com

