

# TFLB120 Damper Actuator Technical Data Sheet

## On/Off, Spring Return, AC 100...240 V, Low Noise



| Technical Data                     |   |
|------------------------------------|---|
| Power Supply                       | 100...240 VAC, -15% / +10%, 50/60 Hz  |
| Power consumption in operation     | 2.5 W   |
| Power consumption in rest position | 1.3 W   |
| Transformer sizing                 | 5 VA  |
| Shaft Diameter                     | 1/4...1/2" round, centers on 1/2"   |
| Electrical Connection              | 18 GA appliance cable, 3 ft [1 m], with 1/2" conduit connector                            |
| Overload Protection                | electronic throughout 0...95° rotation  |
| Electrical Protection              | actuators are double insulated  |
| Angle of rotation                  | Max. 95°, adjustable with mechanical stop   |
| Torque motor                       | 22 in-lb [2.5 Nm]   |
| Direction of motion motor          | selectable by ccw/cw mounting   |
| Direction of motion fail-safe      | reversible with cw/ccw mounting   |
| Position indication                | Mechanical  |
| Running Time (Motor)               | 75 s  |
| Running time fail-safe             | <75 s   |
| Ambient humidity                   | max. 95% r.H., non-condensing   |
| Ambient temperature                | -22...122°F [-30...50°C]  |
| Storage temperature                | -40...176°F [-40...80°C]  |
| Degree of Protection               | IP42, NEMA 2, UL Enclosure Type 2   |
| Housing material                   | UL94-5VA  |
| Agency Listing                     | cULus acc. to UL60730-1A/-2-14, CAN/CSA E60730-1:02, CE acc. to 2014/30/EU and 2014/35/EU |
| Noise level, motor                 | <40 dB(A)   |
| Noise level, fail-safe             | <40 dB(A)   |
| Servicing                          | maintenance-free  |
| Quality Standard                   | ISO 9001  |
| Weight                             | 1.6 lb [0.73 kg]  |

†Rated Impulse Voltage 4kV, Type of action 1.AA, Control Pollution Degree 3.

**Torque min. 22 in-lb, for control of air dampers.**

### Application

For On/Off, fail-safe control of dampers in HVAC systems. Actuator sizing should be done in accordance with the damper manufacturer's specifications. Control is On/Off from an auxiliary contact, or a manual switch. The actuator is mounted directly to a damper shaft from 1/4" up to 1/2" in diameter by means of its universal clamp, 1/2" shaft centered at delivery. A crank arm and several mounting brackets are available for applications where the actuator cannot be direct coupled to the damper shaft.

### Operation

The TF series actuators provide true spring return operation for reliable fail-safe application and positive close off on air tight dampers. The spring return system provides consistent torque to the damper with, and without, power applied to the actuator. The TF series provides 95° of rotation and is provided with a graduated position indicator showing 0° to 90°. The actuator may be stalled anywhere in its normal rotation without the need of mechanical end switches. Power consumption is reduced in holding mode. The actuator is double insulated so an electrical ground connection is not necessary.

**Safety Note:** Screw a conduit fitting into the actuator's bushing. Jacket the actuator's input and output wiring with suitable flexible conduit. Properly terminate the conduit in a suitable junction box.

### Dimensions (Inches[mm])

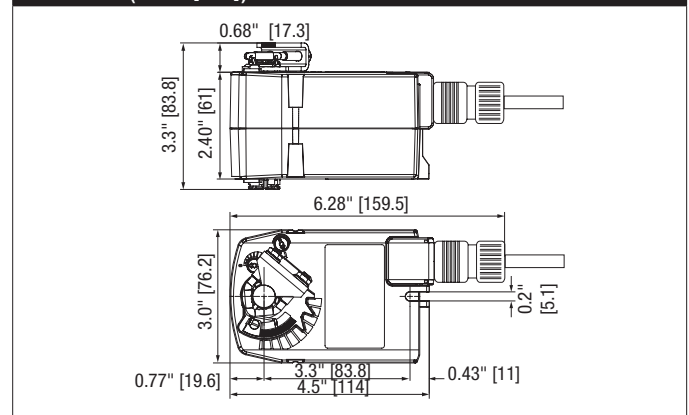

| Accessories   |   |
|---------------|---|
| AV6-20        | Shaft extension   |
| IND-TF        | TF position indicator.                                      |
| K8 US         | Standard TFB(X) clamp (1/4" to 1/2").                       |
| KG10A         | Ball joint  |
| KG8           | Ball joint  |
| KH8           | Damper crank arm  |
| KH-TF US      | TFB(X) crankarm with 5/16" slot.                            |
| KH-TF-1 US    | TFB(X) crankarm with 1/4" slot.                             |
| SB-TF         | Screw fastening kit   |
| SH10          | Push rod for KG10A ball joint (36" L, 3/8" diameter).       |
| SH8           | Push rod for KG6 & KG8 ball joints (36" L, 5/16" diameter). |
| TF-P          | Anti-rotation bracket TF/NKQ/AM/NM/LM.                      |
| TOOL-06       | 8 mm and 10 mm wrench.                                      |
| ZDB-TF        | Angle of rotation limiter                                   |
| ZG-113        | TFB(X) right angle bracket 4-1/2x5-1/2x2-1/2" (HxWxD).      |
| ZG-DC1        | Damper clip for damper blade, 3.5" width.                   |
| ZG-DC2        | Damper clip for damper blade, 6" width.                     |
| ZG-LMSA-1     | Shaft extension for 3/8" diameter shafts (4" L).            |
| ZG-LMSA-1/2-5 | Shaft extension for 1/2" diameter shafts (5" L).            |
| ZG-TF112      | TFB(X) crankarm adaptor kit (includes ZG-113).              |
| ZG-TF2        | TFB(X) crankarm adaptor kit (T bracket included).           |
| ZS-100        | Weather shield - galvaneal 13x8x6" (LxWxD).                 |
| ZS-101        | Base plate for ZS-100.                                      |
| ZS-150        | Weather shield - PC w/ foam seal 16x8-3/8x4" (LxWxD).       |
| P475          | Shaft mount, non-Mercury aux. switch for 1/2" dia. shafts.  |
| P475-1        | Shaft mount, non-Mercury aux. switch for 1" dia. shafts.    |
| PS-100        | Low voltage and control signal simulator.                   |
| TF-CC US      | Cable conduit connector, 1/2".                              |

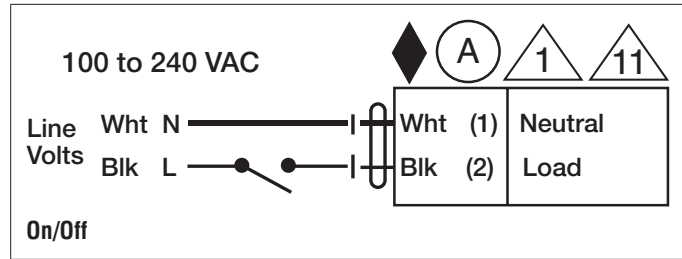

### Typical Specification

On/Off spring return damper actuators shall be direct coupled type which require no crank arm and linkage and be capable of direct mounting to a shaft up to a 1/2" diameter and center a 1/2" shaft. The actuators must be designed so that they may be used for either clockwise or counter clockwise fail-safe operation. Actuators shall be protected from overload at all angles of rotation. If required, one SPDT auxiliary switch shall be provided having the capability of being adjustable. Actuators with auxiliary switch must be constructed to meet the requirements for Double Insulation so an electrical ground is not required to meet agency listings. Actuators shall be cULus listed, have a 5 year warranty, and be manufactured under ISO 9001 International Quality Control Standards. Actuators shall be as manufactured by Belimo.

### Wiring Diagrams

- WARNING! LIVE ELECTRICAL COMPONENTS!**  
During installation, testing, servicing and troubleshooting of this product, it may be necessary to work with live electrical components. Have a qualified licensed electrician or other individual who has been properly trained in handling live electrical components perform these tasks. Failure to follow all electrical safety precautions when exposed to live electrical components could result in death or serious injury.
- Meets cULus requirements without the need of an electrical ground connection.
- Actuators with appliance cables are numbered.
- Provide overload protection and disconnect as required.
- Actuators may be connected in parallel if not mechanically linked. Power consumption and input impedance must be observed.