

# NFB24-MFT

## Modulating, Spring Return, 24 V, Multi-Function Technology®



### Technical Data

Power Supply	24 VAC, ±20%, 50/60 Hz, 24 VDC, -10% / +20%
Power consumption in operation	6.5 W
Power consumption in rest position	3 W
Transformer sizing	9 VA (class 2 power source)
Shaft Diameter	1/2...1.05" round, centers on 1/2" and 3/4" with insert, 1.05" without insert
Electrical Connection	18 GA appliance cable, 3 ft [1 m], with 1/2" conduit connector
Overload Protection	electronic throughout 0...95° rotation
Electrical Protection	actuators are double insulated
Operating Range	2...10 V (default), 4...20 mA w/ ZG-R01 (500 Ω, 1/4 W resistor), variable (VDC, PWM, on/off, floating point)
Operating range Y variable	Start point 0.5...30 V End point 2.5...32 V
Input Impedance	100 kΩ for 2...10 V (0.1 mA), 500 Ω for 4...20 mA, 1500 Ω for PWM, On/Off and Floating point
Position Feedback	2...10 V, Max. 0.5 mA, VDC variable
Angle of rotation	95°, adjustable with mechanical end stop, 35...95°
Torque motor	90 in-lb [10 Nm]
Direction of motion motor	selectable with switch 0/1
Direction of motion fail-safe	reversible with cw/ccw mounting
Position indication	Mechanical
Manual override	5 mm hex crank (3/16" Allen), supplied
Running Time (Motor)	default 150 s, variable 40...150 s
Running time fail-safe	<20 s @ -4...122°F [-20...50°C], <60 s @ -22°F [-30°C]
Angle of rotation adaptation	off (default)
Override control	MIN (minimum position) = 0% MID (intermediate position) = 50% MAX (maximum position) = 100%
Ambient humidity	max. 95% r.H., non-condensing
Ambient temperature	-22...122°F [-30...50°C]
Storage temperature	-40...176°F [-40...80°C]
Degree of Protection	IP54, NEMA 2, UL Enclosure Type 2
Housing material	Galvanized steel and plastic housing
Agency Listing	cULus acc. to UL60730-1A/-2-14, CAN/CSA E60730-1:02, CE acc. to 2014/30/EU
Noise level, motor	40 dB(A)
Noise level, fail-safe	62 dB(A)
Servicing	maintenance-free
Quality Standard	ISO 9001
Weight	5.0 lb [2.3 kg]

\*Variable when configured with MFT options.

†Rated Impulse Voltage 800V, Type of action 1.AA, Control Pollution Degree 3

**Torque min. 90 in-lb, Control DC 2...10 V (DEFAULT), Feedback DC 2...10 V (DEFAULT)**

### Application

For fail-safe, modulating control of dampers in HVAC systems. Actuator sizing should be done in accordance with the damper manufacturer's specifications. A feedback signal is provided for position indication.

### Default/Configuration

Default parameters for 2 to 10 VDC applications of the NF.-MFT actuator are assigned during manufacturing. If required, custom versions of the actuator can be ordered. The parameters are variable and can be changed by three means: Factory pre-set or custom configuration, set by the customer using PC-Tool software or the handheld ZTH US.

### Operation

The NF.24-MFT actuator provides 95° of rotation and is provided with a graduated position indicator showing 0° to 95°. The actuator will synchronize the 0° mechanical stop or the physical damper or valve mechanical stop and use this point for its zero position during normal control operations. A unique manual override allows the setting of any actuator position within its 95° of rotation with no power applied. This mechanism can be released physically by the use of a crank supplied with the actuator. When power is applied the manual override is released and the actuator drives toward the fail-safe position. The actuator uses a brushless DC motor which is controlled by an Application Specific Integrated Circuit (ASIC) and a microprocessor. The microprocessor provides the intelligence to the ASIC to provide a constant rotation rate and to know the actuators's exact position. The ASIC monitors and controls the brushless DC motor's rotation and provides a Digital Rotation Sensing (DRS) function to prevent damage to the actuator in a stall condition. The position feedback signal is generated without the need for mechanical feedback potentiometers using DRS. The actuator may be stalled anywhere in its normal rotation without the need of mechanical end switches. The NF.24-MFT is mounted directly to control shafts up to 1.05" diameter by means of its universal clamp and anti-rotation bracket. A crank arm and several mounting brackets are available for damper applications where the actuator cannot be direct coupled to the damper shaft. The spring return system provides minimum specified torque to the application during a power interruption. The NF.24-MFT actuator is shipped at 5° (5° from full fail-safe) to provide automatic compression against damper gaskets for tight shut-off.

### Dimensions (Inches[mm])

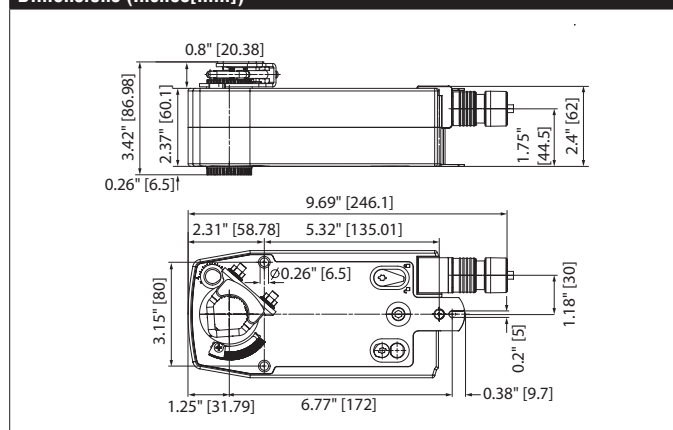

Accessories	
AF-P	Anti-rotation bracket AF/NF.
AV8-25	Shaft extension
IND-AFB	End stop indicator
K7-2	Shaft clamp reversible
KG10A	Ball joint
KG8	Ball joint
KH10	Damper crank arm
KH8	Damper crank arm
KH-AFB	Actuator arm
SH10	Push rod for KG10A ball joint (36" L, 3/8" diameter).
SH8	Push rod for KG6 & KG8 ball joints (36" L, 5/16" diameter).
TOOL-06	8 mm and 10 mm wrench.
ZG-100	Univ. right angle bracket 17"x11-1/8"x6" (HxWxbase).
ZG-101	Univ. right angle bracket 13x11x7-7/16" (HxWxbase).
ZG-109	Right angle bracket for ZS-260.
ZG-110	Stand-off bracket for ZS-260.
ZG-118	AFB(X)/NFB(X) U bracket 5-7/8x5-1/2x2-19/32" (HxWxD).
ZG-120	Jackshaft mounting bracket.
ZG-AFB	Mounting kit for linkage operation
ZG-AFB118	AFB(X)/NFB(X) crankarm adaptor kit.
ZG-DC1	Damper clip for damper blade, 3.5" width.
ZG-DC2	Damper clip for damper blade, 6" width.
ZG-JSA-1	1" diameter jackshaft adaptor (11" L).
ZG-JSA-2	1-5/16" diameter jackshaft adaptor (12" L).
ZG-JSA-3	1.05" diameter jackshaft adaptor (12" L).
ZS-100	Weather shield - galvanneal 13x8x6" (LxWxD).
ZS-101	Base plate for ZS-100.
ZS-150	Weather shield - PC w/ foam seal 16x8-3/8x4" (LxWxD).
ZS-260	Explosion proof housing.
ZS-300	NEMA 4X, 304 stainless steel enclosure.
ZS-300-5	NEMA 4X, 316L stainless steel enclosure.
ZS-300-C1	1/2" shaft adaptor, standard with ZS-300(-5).
ZS-300-C2	3/4" shaft adaptor for ZS-300(-5).
ZS-300-C3	1" shaft adaptor for ZS-300(-5).
Z-SF	Base plate extension
IRM-100	Input rescaling module for modulating actuators.
MFT-P	Belimo PC-Tool
P475	Shaft mount, non-Mercury aux. switch for 1/2" dia. shafts.
P475-1	Shaft mount, non-Mercury aux. switch for 1" dia. shafts.
PS-100	Low voltage and control signal simulator.
PTA-250	Pulse width modulation interface for modulating actuators.
SGA24	Positioners suitable for use with the modulating damper actuators LM..A-SR, NM..A-SR, SM..A-SR and GM..A-SR
SGF24	Positioners suitable for use with the modulating damper actuators LM..A-SR, NM..A-SR, SM..A-SR and GM..A-SR
TF-CC US	Cable conduit connector, 1/2".
UK24BAC	Gateway MP to BACnet MS/TP
UK24LON	Gateway MP to LonWorks
UK24MOD	Gateway MP to Modbus RTU
ZG-R01	4 to 20 mA adaptor, 500Ω, 1/4 W resistor w 6" pigtail wires.
ZG-R02	50% voltage divider kit (resistors with wires).
ZG-SGF	Mounting plate for SGF.
ZG-X40	120 to 24 VAC, 40 VA transformer.
ZK2-GEN	Connection cable
ZTH US	Handheld programming tool w/ ZK1-GEN, ZK2-GEN, ZK6-GEN.

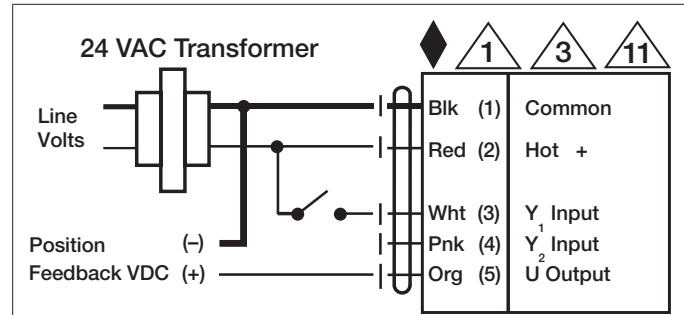
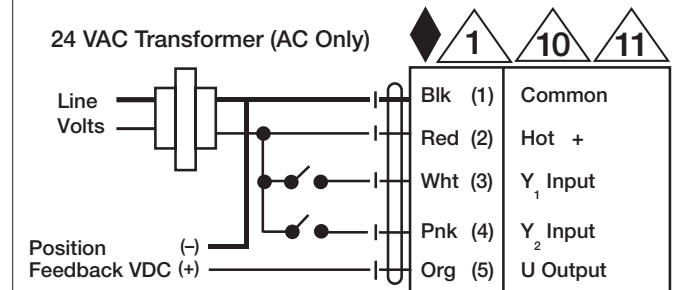
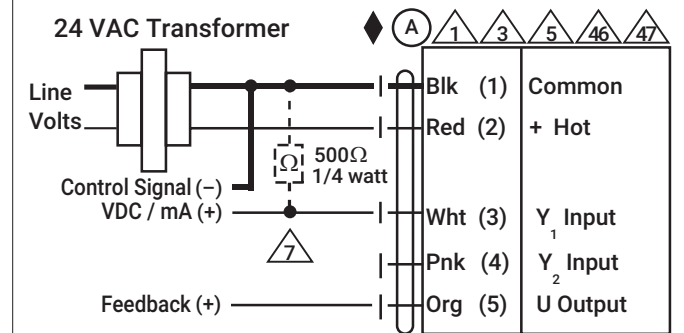
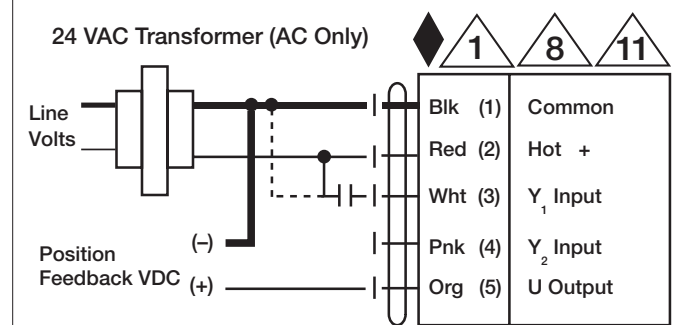
**On/Off**

**Floating Point**

**VDC/mA Control**

**PWM Control**

# NFB24-MFT

## Modulating, Spring Return, 24 V, Multi-Function Technology®

### Typical Specification

Spring return control damper actuators shall be direct coupled type which require no crank arm and linkage and be capable of direct mounting to a jackshaft up to a 1.05" diameter. The actuator must provide modulating damper control in response to a 2 to 10 VDC or, with the addition of a 500Ω resistor, a 4 to 20 mA control input from an electronic controller or positioner. The actuators must be designed so that they may be used for either clockwise or counter clockwise fail-safe operation. Actuators shall use a brushless DC motor controlled by a microprocessor and be protected from overload at all angles of rotation. Run time shall be constant, and independent of torque. A 2 to 10 VDC feedback signal shall be provided for position feedback. Actuators shall be cULus listed and have a 5 year warranty, and be manufactured under ISO 9001 International Quality Control Standards. Actuators shall be as manufactured by Belimo.

### Wiring Diagrams

**⚠ WARNING! LIVE ELECTRICAL COMPONENTS!**  
 During installation, testing, servicing and troubleshooting of this product, it may be necessary to work with live electrical components. Have a qualified licensed electrician or other individual who has been properly trained in handling live electrical components perform these tasks. Failure to follow all electrical safety precautions when exposed to live electrical components could result in death or serious injury.

◆ Meets cULus requirements without the need of an electrical ground connection.

Ⓐ Actuators with appliance cables are numbered.

① Provide overload protection and disconnect as required.

③ Actuators may also be powered by 24 VDC.

⑤ Only connect common to negative (-) leg of control circuits.

⑦ A 500 Ω resistor (ZG-R01) converts the 4 to 20 mA control signal to 2 to 10 VDC.

⑧ Control signal may be pulsed from either the Hot (Source) or Common (Sink) 24 VAC line.

⑩ For triac sink the Common connection from the actuator must be connected to the Hot connection of the controller. Position feedback cannot be used with a triac sink controller; the actuator internal common reference is not compatible.

⑪ Actuators may be connected in parallel if not mechanically linked. Power consumption and input impedance must be observed.

⑫ IN4004 or IN4007 diode. (IN4007 supplied, Belimo part number 40155).

