

FSTF24 US

On/Off, Spring Return Fail-Safe, 24 VAC



Technical Data	
Power Supply	24 VAC ± 20%, 24 VDC -10% + 20%
Power Consumption Running	2 W, 3 VA
Power Consumption Holding	1.5 W, 2 VA
Transformer Sizing	5 VA (class 2 power source)
Shaft Diameter	1/4" to 1/2" round, centers on 1/2"
Electrical Connection	3 ft., 18 GA appliance cable, 1/2" conduit connector
Overload Protection	electronic throughout 0° to 95° rotation
Electrical Protection	actuators are double insulated
Angle of Rotation	95°
Torque	18 in-lbs [2 Nm] minimum
Direction of Rotation	can be selected by CCW/CW mounting
Position Indication	visual indicator, 0° to 95° (0° is full spring return position)
Manual Override	No
Running Time (Motor)	<75 seconds @ 250°F [121°C]
Running Time (Fail-Safe)	< 25 seconds @ 32°F to 122°F [0°C to 50°C]
Humidity	5 to 95% RH non-condensing
Ambient Temperature Range	32°F to +122°F [0°C to +50°C]
Storage Temperature Range	-40°F to +176°F [-40°C to +80°C]
Housing	NEMA 2, IP42, UL enclosure type 2
Housing Material	UL94-5VA
Agency Listings†	cULus acc. to UL60730-1A/-2-14, CAN/CSA E60730-1:02, Listed to UL 2043 - suitable for use in air plenums per Section 300.22(C) of the NEC and Section 602 of the IMC
Noise Level (Motor)	<45 dB (A)
Noise Level (Fail-Safe)	<62 dB (A)
Servicing	maintenance free
Quality Standard	ISO 9001
Weight	1.26 lbs. (0.57 kg.)

Part no.	Clamp side spring return
FSTF120 US	CW
FSTF120.1 US	CW (bulk pack)
FSTF120.1 CCW	CCW (bulk pack)
FSTF120-S US CW	CW
FSTF120-S.1 US	CW (bulk pack)
FSTF120-S.1 CCW	CCW (bulk pack)

† UL File XAPX.E108966

Torque 18 in-lb, 250°F for 30 min, for fire and smoke dampers

Application

The type FSTF spring-return actuator is intended for the operation of smoke and combination fire and smoke dampers in ventilation and air-conditioning systems. The actuator will meet requirements of UL555 and UL555S when tested as an assembly with the damper. Square footage of damper operated will depend on make and model per damper manufacturer UL testing.

Operation

Mounting of the actuator to the damper axle shaft or jackshaft is via a cold-weld clamp. Teeth in the clamp and V-bolt dig into the metal of both solid and hollow shafts maintaining a perfect connection. The specially designed clamp will not crush hollow shafts. The bottom end of the actuator is held by an anti-rotation strap or by a stud provided by the damper manufacturer. The actuator is mounted in its fail safe position with the damper blade(s) typically closed. Upon applying power, the actuator drives the damper to the open position. The internal spring is tensioned at the same time. If the power supply is interrupted, the spring moves the damper back to its fail-safe position.

Dimensions (Inches[mm])

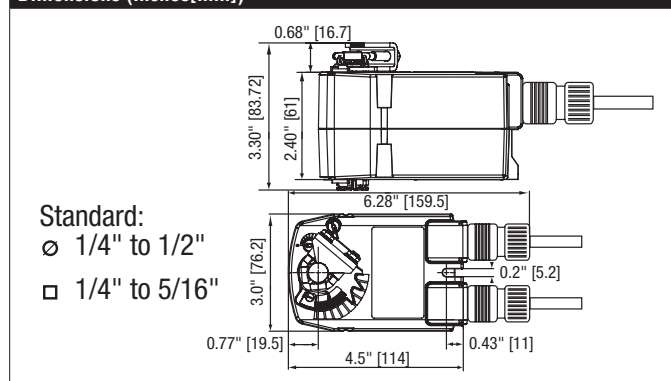

Safety Notes

Screw a conduit fitting into the actuator's bushing. Jacket the actuator's input and output wiring with suitable flexible conduit. Properly terminate the conduit in a suitable junction box.

Retrofit Safety Note

Use of the FSTF for replacement of other makes of actuators is limited in damper area. The FSLF is preferred for direct coupled applications. The FSTF may be applied for linkage applications on dampers 1.5 sq.ft. and smaller at velocities under 2000 fpm.

Accessories	
KH-TF US	Crankarm for Shafts to 1/2"
KH-TF-1 US	Crankarm for Shafts with 1/4" slot
KH-TF-1.1 US	Crankarm for Shafts with 1/4" slot
TF-P	Anti-Rotation Bracket
TOOL-06	8 mm and 10 mm Wrench
ZDB-TF	Angle of Rotation Limiter for TF
ZG-TF2	Crankarm Adaptor Kit (includes mounting hardware)
ZG-TF3	TF mounting tubes and hardware kit
ZG-TF112	Crankarm Adaptor Kit (includes ZG-113 and KH-TF)
ZS-100	Weather Shield - Galvaneal
ZS-150	Weather Shield - Polycarbonate
BAE165 US	165°F electric thermal sensor. SPST, NC

Typical Specification

All smoke and combination fire and smoke dampers shall be provided with Belimo FSTF, FSLF, FSNF, or FSAF actuators. All substitutions must be approved before submission of bid. Damper and actuator shall have UL 555S Listing for 250°F &/or 350°F. Actuator shall have been tested to UL 2043 per requirements of IMC 602.2 and NEC 300.22 (c). Where position indication is required -S models with auxiliary switches or damper blade switches will be provided per code requirements.

Wiring Diagrams

- Provide overload protection and disconnect as required.
- Actuators may also be powered by 24 VDC.
- Actuators may be powered in parallel. Power consumption must be observed.
- Ground present on some models.
- Meets cULus requirements without the need of an electrical ground connection.

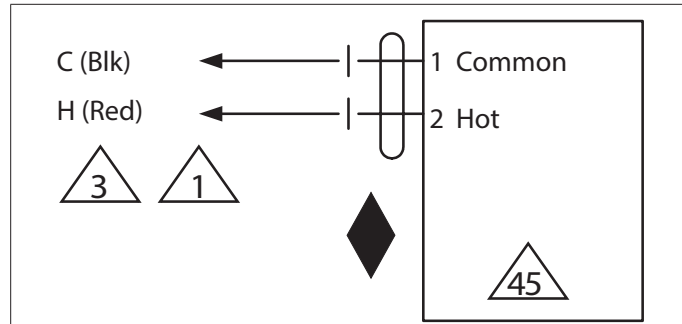

24 VAC/DC

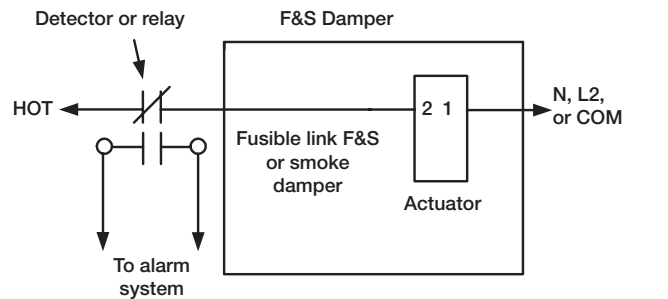

Typical smoke or fusible link damper wiring

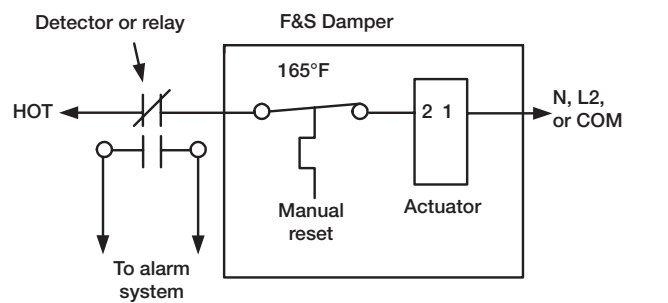

Typical containment damper control wiring

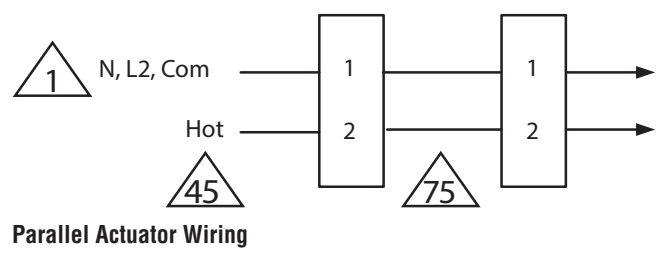

Parallel Actuator Wiring

FSTF24-S US

On/Off, Spring Return, 24 VAC, Auxiliary Switch



Technical Data

Power Supply	24 VAC \pm 20%, 24 VDC -10% + 20%
Power Consumption Running	2 W, 3 VA
Power Consumption Holding	1.5 W, 2 VA
Transformer Sizing	5 VA (class 2 power source)
Shaft Diameter	1/4" to 1/2" round, centers on 1/2"
Electrical Connection	(2) 3 ft, 18 GA appliance cables with 1/2" conduit connectors
Overload Protection	electronic throughout 0° to 95° rotation
Electrical Protection	actuators are double insulated
Angle of Rotation	95°
Torque	18 in-lbs [2 Nm] minimum
Direction of Rotation	can be selected by CCW/CW mounting
Position Indication	visual indicator, 0° to 95° (0° is full spring return position)
Manual Override	No
Running Time (Motor)	<75 seconds @ 250°F [121°C]
Running Time (Fail-Safe)	< 25 seconds @ 32°F to 122°F [0°C to 50°C]
Humidity	5 to 95% RH non-condensing
Ambient Temperature Range	32°F to +122°F [0°C to +50°C]
Storage Temperature Range	-40°F to +176°F [-40°C to +80°C]
Housing	NEMA 2, IP42, UL enclosure type 2
Housing Material	UL94-5VA
Agency Listings†	cULus acc. to UL60730-1A/-2-14, CAN/CSA E60730-1:02, Listed to UL 2043 - suitable for use in air plenums per Section 300.22(C) of the NEC and Section 602 of the IMC
Noise Level (Motor)	<45 dB (A)
Noise Level (Fail-Safe)	<62 dB (A)
Servicing	maintenance free
Quality Standard	ISO 9001
Weight	1.5 lbs. (0.68 kg.)
Auxiliary Switch	2 x SPST 3A resistive (0.5A inductive) @ 120 VAC, one fixed at 10° and one fixed at 80°

Part no.	Clamp side spring return
FSTF120 US	CW
FSTF120.1 US	CW (bulk pack)
FSTF120.1 CCW	CCW (bulk pack)
FSTF120-S US CW	CW
FSTF120-S.1 US	CW (bulk pack)
FSTF120-S.1 CCW	CCW (bulk pack)

† UL File XAPX.E108966

Torque 18 in-lb, 250°F for 30 min, for fire and smoke dampers

Application

The type FSTF spring-return actuator is intended for the operation of smoke and combination fire and smoke dampers in ventilation and air-conditioning systems. The actuator will meet requirements of UL555 and UL555S when tested as an assembly with the damper. Square footage of damper operated will depend on make and model per damper manufacturer UL testing.

Operation

Mounting of the actuator to the damper axle shaft or jackshaft is via a cold-weld clamp. Teeth in the clamp and V-bolt dig into the metal of both solid and hollow shafts maintaining a perfect connection. The specially designed clamp will not crush hollow shafts. The bottom end of the actuator is held by an anti-rotation strap or by a stud provided by the damper manufacturer. The actuator is mounted in its fail safe position with the damper blade(s) typically closed. Upon applying power, the actuator drives the damper to the open position. The internal spring is tensioned at the same time. If the power supply is interrupted, the spring moves the damper back to its fail-safe position.

Dimensions (Inches[mm])

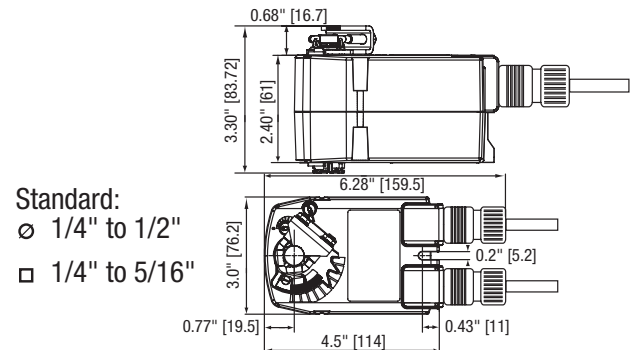

Standard:
 ∅ 1/4" to 1/2"
 □ 1/4" to 5/16"

Safety Notes

Screw a conduit fitting into the actuator's bushing. Jacket the actuator's input and output wiring with suitable flexible conduit. Properly terminate the conduit in a suitable junction box.

Retrofit Safety Note

Use of the FSTF for replacement of other makes of actuators is limited in damper area. The FSLF is preferred for direct coupled applications. The FSTF may be applied for linkage applications on dampers 1.5 sq.ft. and smaller at velocities under 2000 fpm.

Accessories	
KH-TF US	Crankarm for Shafts to 1/2"
KH-TF-1 US	Crankarm for Shafts with 1/4" slot
KH-TF-1.1 US	Crankarm for Shafts with 1/4" slot
TF-P	Anti-Rotation Bracket
TOOL-06	8 mm and 10 mm Wrench
ZDB-TF	Angle of Rotation Limiter for TF
ZG-TF2	Crankarm Adaptor Kit (includes mounting hardware)
ZG-TF3	TF mounting tubes and hardware kit
ZG-TF112	Crankarm Adaptor Kit (includes ZG-113 and KH-TF)
ZS-100	Weather Shield - Galvaneal
ZS-150	Weather Shield - Polycarbonate
BAE165 US	165°F electric thermal sensor. SPST, NC

Typical Specification

All smoke and combination fire and smoke dampers shall be provided with Belimo FSTF, FSLF, FSNF, or FSAF actuators. All substitutions must be approved before submission of bid. Damper and actuator shall have UL 555S Listing for 250°F &/or 350°F. Actuator shall have been tested to UL 2043 per requirements of IMC 602.2 and NEC 300.22 (c). Where position indication is required -S models with auxiliary switches or damper blade switches will be provided per code requirements.

Wiring Diagrams

- Provide overload protection and disconnect as required.
- Actuators may also be powered by 24 VDC.
- Actuators may be powered in parallel. Power consumption must be observed.
- S4 makes to S6 when actuator is powered open.
- Auxiliary switches are for end position indication or interlock control.
- Double insulated.
- Ground present on some models.
- Meets cULus requirements without the need of an electrical ground connection.

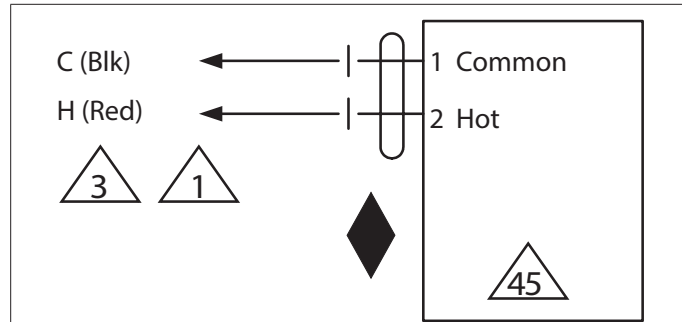

24 VAC/DC

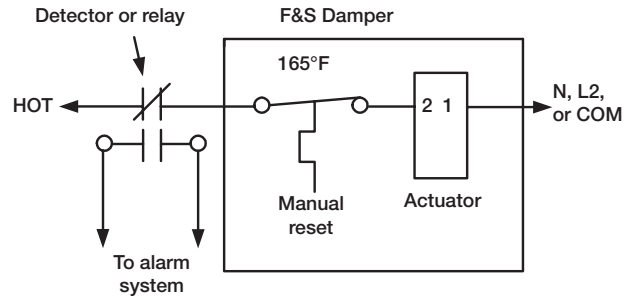

Typical containment damper control wiring

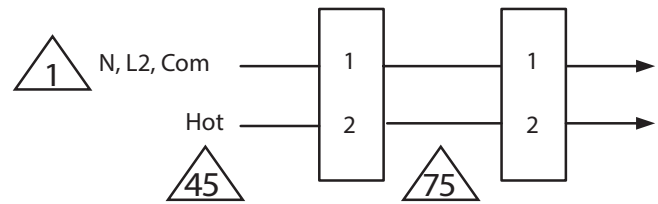

Parallel Actuator Wiring

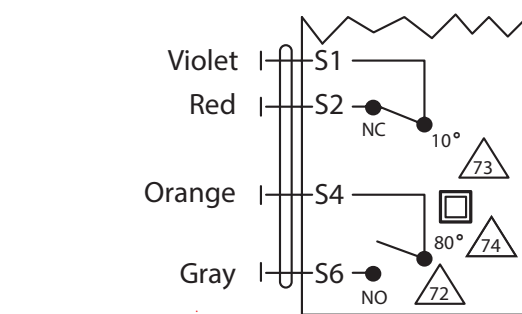

Auxiliary Switch



Technical Data		FSTF120(-S) US
Power supply	nominal	120 VAC, 60 Hz
	tolerance	108 to 132 VAC, 60 Hz
Power consumption	running	2 W, 3.5 VA
	holding	1.5 W, 2.5 VA
	max. inrush current	2.1 A
Transformer sizing		5 VA (class 2 power source)
Electrical connection (-S models have 2 cables)		3 ft, 18 GA appliance cable
		1/2" conduit connector
Overload protection		electronic throughout 0 to 95° rotation
Electrical protection		actuators are double insulated
Angle of rotation		max 95°, adjust. with mechanical stop
Torque		min. 18 in-lb [2 Nm]
Direction of rotation		reversible with cw/ccw mounting
Position indication		visual indicator, 0° to 95°
		(0° spring return position)
Running time	motor	< 75 sec (0 to 18 in-lb)
	spring	< 25 sec @32°F to 122°F [0°C to 50°C]
Humidity		5 to 95% RH non-condensing
Ambient temperature		32°F to 122°F [0°C to 50°C]
Operating temperature		Up to 250°F for 1/2 hour per UL555S test
Housing		NEMA type 2 / IP42, UL enclosure type 2
Housing material		UL94-5VA. UL2043 Listed for plenum use
Agency listings†		cULus acc. to UL60730-1A/-2-14, CAN/CSA E60730-1:02, CE acc. to 2004/108/EC (and 2006/95/EC for -S versions). UL2043 smoke rated
Noise level (max)	running	< 50 db (A)
	spring return	62 db (A)
	holding	inaudible
Servicing		maintenance free
Quality standard		ISO 9001
Weight	FSTF120 US	1.26 lbs (0.57 kg)
	FSTF120-S US	1.5 lbs (0.68 kg)

† Rated Impulse Voltage 4kV, Type of action 1.AA (1.AA.B for -S version), Control Pollution Degree 3.

FSTF120-S US

Auxiliary switch	2 x SPST 3A (0.5A) @ 120 VAC, UL approved One fixed at 10° and one fixed at 80°
------------------	--

Torque min. 18 in-lb, for control of fire and smoke dampers

Application

The type FSTF spring-return actuator is intended for the operation of smoke and combination fire and smoke dampers in ventilation and air-conditioning systems. The actuator will meet requirements of UL555 and UL555S when tested as an assembly with the damper Square footage of damper operated will depend on make and model and the temperature required.

Operation

Mounting of the actuator to the damper axle shaft or jackshaft is via a cold-weld clamp. Teeth in the clamp and V-bolt dig into the metal of both solid and hollow shafts maintaining a perfect connection. The specially designed clamp will not crush hollow shafts. The bottom end of the actuator is held by an anti-rotation strap or by a stud provided by the damper manufacturer.

The actuator is mounted in its fail safe position with the damper blade(s) typically closed. Upon applying power, the actuator drives the damper to the open position. The internal spring is tensioned at the same time. If the power supply is interrupted, the spring moves the damper back to its fail-safe position.

SAFETY NOTE

Screw a conduit fitting into the actuator's bushing. Jacket the actuator's input and output wiring with suitable flexible conduit. Properly terminate the conduit in a suitable junction box.

Dimensions (Inches [mm])

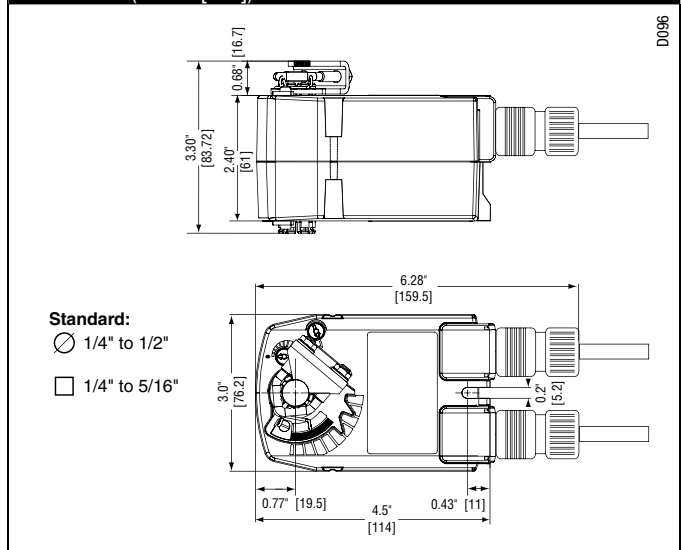

FSTF120(-S) US

On/Off, Spring Return, 120 VAC



Accessories

Tool-06	8mm and 10 mm wrench
KH-TF	Crank arm for up to 1/2" round shaft
ZG-TF2	Crank arm adaptor kit for FSTF
ZG-TF112	Mounting bracket, kit for FSTF
ZS-100	Weather shield (metal)
ZS-150	Weather shield (polycarbonate)

NOTE: When using FSTF120 US and FSTF120-S US actuators, only use accessories listed on this page or those provided by damper manufacturers.

For actuator wiring information and diagrams, refer to Belimo Wiring Guide.

Typical Specification

On/Off fire and smoke spring return damper actuators shall be direct coupled type which require no crank arm and linkage and be capable of direct mounting to a shaft up to a 1/2" diameter and center a 1/2" shaft. The actuators must be designed so that they may be used for either clockwise or counterclockwise fail-safe operation. Actuators shall be protected from overload at all angles of rotation. If required, two SPDT auxiliary switches shall be provided. Actuators shall be cULus listed and have a 5 year warranty, and be manufactured under ISO 9001 International Quality Control Standards. Actuators shall be as manufactured by Belimo.

Wiring Diagrams

✂ INSTALLATION NOTES

1 Provide overload protection and disconnect as required.

2 **CAUTION Equipment Damage!**
Actuators may be connected in parallel. Power consumption must be observed.

4 Two SPST auxiliary switches for position indication. NC switch opens at 10° and NO switch closes at 80°

📄 APPLICATION NOTES

◆ Meets cULus requirements without the need of an electrical ground connection.

⚠ WARNING Live Electrical Components!

During installation, testing, servicing and troubleshooting of this product, it may be necessary to work with live electrical components. Have a qualified licensed electrician or other individual who has been properly trained in handling live electrical components perform these tasks. Failure to follow all electrical safety precautions when exposed to live electrical components could result in death or serious injury.

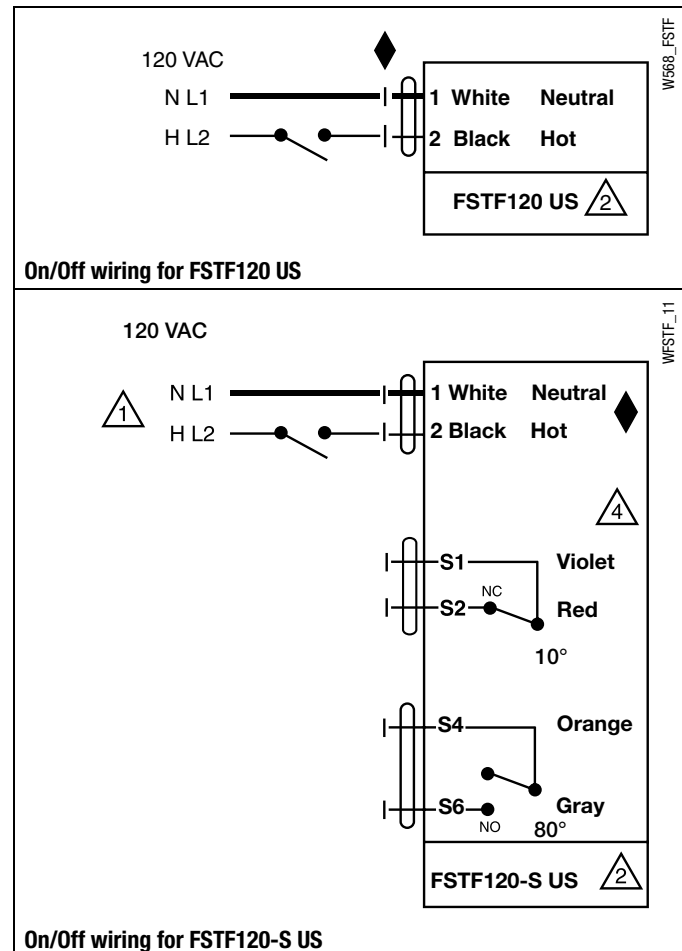

M40024 - 05/11 - Subject to change. © Belimo Aircontrols (USA), Inc.

FSTF230 US

On/Off, Spring Return Fail-Safe, 230 VAC



Technical Data

Power Supply	230 VAC \pm 10%, 50/60 Hz
Power Consumption Running	5 VA
Power Consumption Holding	4.5 VA
Shaft Diameter	1/4" to 1/2" round, centers on 1/2"
Electrical Connection	3 ft., 18 GA appliance cable, 1/2" conduit connector
Overload Protection	electronic throughout 0° to 95° rotation
Electrical Protection	actuators are double insulated
Angle of Rotation	95°
Torque	18 in-lbs [2 Nm] minimum
Direction of Rotation	can be selected by CCW/CW mounting
Position Indication	visual indicator, 0° to 95° (0° is full spring return position)
Manual Override	No
Running Time (Motor)	<75 seconds @ 250°F [121°C]
Running Time (Fail-Safe)	< 25 seconds @ 32°F to 122°F [0°C to 50°C]
Humidity	5 to 95% RH non-condensing
Ambient Temperature Range	32°F to +122°F [0°C to +50°C]
Storage Temperature Range	-40°F to +176°F [-40°C to +180°C]
Housing	NEMA 2, IP42, UL enclosure type 2
Housing Material	UL94-5VA
Agency Listings†	cULus acc. to UL60730-1A/-2-14, CAN/CSA E60730-1:02, Listed to UL 2043 - suitable for use in air plenums per Section 300.22(C) of the NEC and Section 602 of the IMC
Noise Level (Motor)	<45 dB (A)
Noise Level (Fail-Safe)	<62 dB (A)
Servicing	maintenance free
Quality Standard	ISO 9001
Weight	1.26 lbs. (0.57 kg.)

Part no.	Clamp side spring return
FSTF120 US	CW
FSTF120.1 US	CW (bulk pack)
FSTF120.1 CCW	CCW (bulk pack)
FSTF120-S US CW	CW
FSTF120-S.1 US	CW (bulk pack)
FSTF120-S.1 CCW	CCW (bulk pack)

† UL File XAPX.E108966

Torque 18 in-lb, 250°F for 30 min, for fire and smoke dampers

Application

The type FSTF spring-return actuator is intended for the operation of smoke and combination fire and smoke dampers in ventilation and air-conditioning systems. The actuator will meet requirements of UL555 and UL555S when tested as an assembly with the damper. Square footage of damper operated will depend on make and model per damper manufacturer UL testing.

Operation

Mounting of the actuator to the damper axle shaft or jackshaft is via a cold-weld clamp. Teeth in the clamp and V-bolt dig into the metal of both solid and hollow shafts maintaining a perfect connection. The specially designed clamp will not crush hollow shafts. The bottom end of the actuator is held by an anti-rotation strap or by a stud provided by the damper manufacturer. The actuator is mounted in its fail safe position with the damper blade(s) typically closed. Upon applying power, the actuator drives the damper to the open position. The internal spring is tensioned at the same time. If the power supply is interrupted, the spring moves the damper back to its fail-safe position.

Dimensions (Inches[mm])

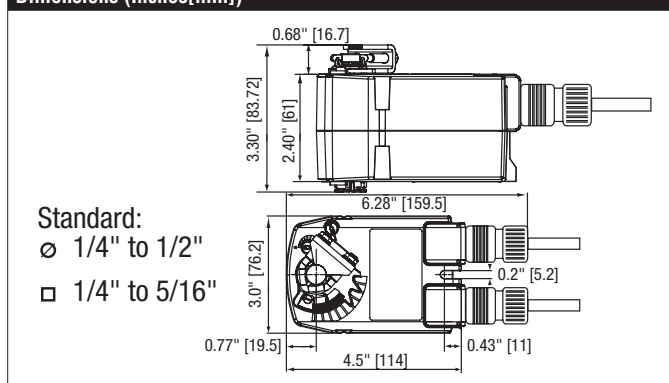

Standard:
 ∅ 1/4" to 1/2"
 □ 1/4" to 5/16"

Safety Notes

Screw a conduit fitting into the actuator's bushing. Jacket the actuator's input and output wiring with suitable flexible conduit. Properly terminate the conduit in a suitable junction box.

Retrofit Safety Note

Use of the FSTF for replacement of other makes of actuators is limited in damper area. The FSLF is preferred for direct coupled applications. The FSTF may be applied for linkage applications on dampers 1.5 sq.ft. and smaller at velocities under 2000 fpm.

Accessories	
KH-TF US	Crankarm for Shafts to 1/2"
KH-TF-1 US	Crankarm for Shafts with 1/4" slot
KH-TF-1.1 US	Crankarm for Shafts with 1/4" slot
TF-P	Anti-Rotation Bracket
TOOL-06	8 mm and 10 mm Wrench
ZDB-TF	Angle of Rotation Limiter for TF
ZG-TF2	Crankarm Adaptor Kit (includes mounting hardware)
ZG-TF3	TF mounting tubes and hardware kit
ZG-TF112	Crankarm Adaptor Kit (includes ZG-113 and KH-TF)
ZS-100	Weather Shield - Galvaneal
ZS-150	Weather Shield - Polycarbonate
BAE165 US	165°F electric thermal sensor. SPST, NC

Typical Specification

All smoke and combination fire and smoke dampers shall be provided with Belimo FSTF, FSLF, FSNF, or FSAF actuators. All substitutions must be approved before submission of bid. Damper and actuator shall have UL 555S Listing for 250°F &/or 350°F. Actuator shall have been tested to UL 2043 per requirements of IMC 602.2 and NEC 300.22 (c). Where position indication is required -S models with auxiliary switches or damper blade switches will be provided per code requirements.

Wiring Diagrams

- Provide overload protection and disconnect as required.
- Actuators may be powered in parallel. Power consumption must be observed.
- Ground present on some models.
- Meets cULus requirements without the need of an electrical ground connection.

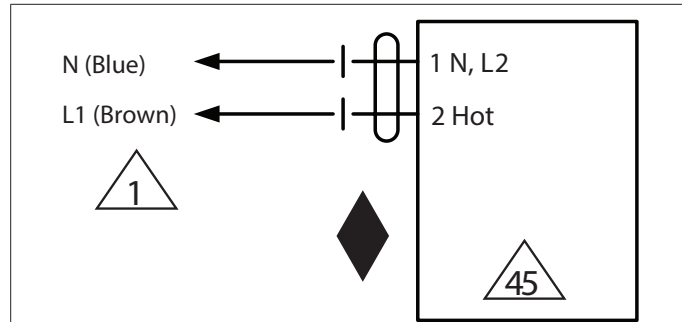

230 VAC

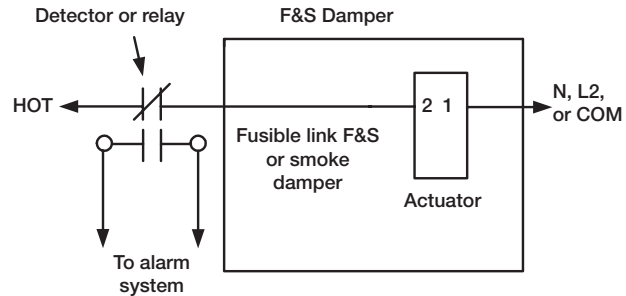

Typical smoke or fusible link damper wiring

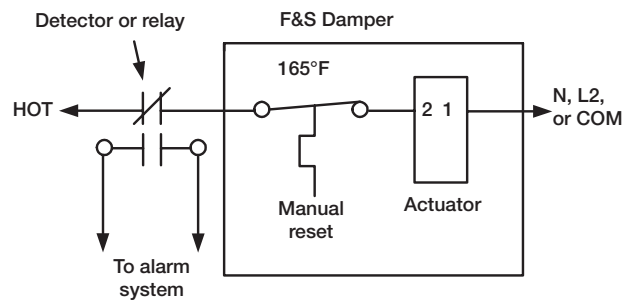

Typical containment damper control wiring

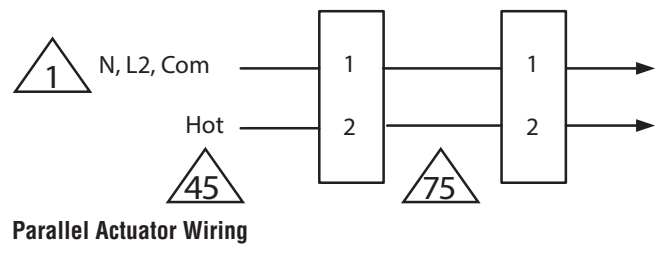

Parallel Actuator Wiring

FSTF230-S US

On/Off, Spring Return, 230 VAC, Auxiliary Switch



Technical Data	
Power Supply	230 VAC ± 10%, 50/60 Hz
Power Consumption Running	5 VA
Power Consumption Holding	4.5 VA
Shaft Diameter	1/4" to 1/2" round, centers on 1/2"
Electrical Connection	(2) 3 ft, 18 GA appliance cables with 1/2" conduit connectors
Overload Protection	electronic throughout 0° to 95° rotation
Electrical Protection	actuators are double insulated
Angle of Rotation	95°
Torque	18 in-lbs [2 Nm] minimum
Direction of Rotation	can be selected by CCW/CW mounting
Position Indication	visual indicator, 0° to 95° (0° is full spring return position)
Manual Override	No
Running Time (Motor)	<75 seconds @ 250°F [121°C]
Running Time (Fail-Safe)	< 25 seconds @ 32°F to 122°F [0°C to 50°C]
Humidity	5 to 95% RH non-condensing
Ambient Temperature Range	32°F to +122°F [0°C to +50°C]
Storage Temperature Range	-40°F to +176°F [-40°C to +80°C]
Housing	NEMA 2, IP42, UL enclosure type 2
Housing Material	UL94-5VA
Agency Listings†	cULus acc. to UL60730-1A/-2-14, CAN/CSA E60730-1:02, Listed to UL 2043 - suitable for use in air plenums per Section 300.22(C) of the NEC and Section 602 of the IMC
Noise Level (Motor)	<45 dB (A)
Noise Level (Fail-Safe)	<62 dB (A)
Servicing	maintenance free
Quality Standard	ISO 9001
Weight	1.5 lbs. (0.68 kg.)
Auxiliary Switch	2 x SPST 3A resistive (0.5A inductive) @ 120 VAC, one fixed at 10° and one fixed at 80°

Part no.	Clamp side spring return
FSTF120 US	CW
FSTF120.1 US	CW (bulk pack)
FSTF120.1 CCW	CCW (bulk pack)
FSTF120-S US CW	CW
FSTF120-S.1 US	CW (bulk pack)
FSTF120-S.1 CCW	CCW (bulk pack)

† UL File XAPX.E108966

Torque 18 in-lb, 250°F for 30 min, for fire and smoke dampers

Application

The type FSTF spring-return actuator is intended for the operation of smoke and combination fire and smoke dampers in ventilation and air-conditioning systems. The actuator will meet requirements of UL555 and UL555S when tested as an assembly with the damper. Square footage of damper operated will depend on make and model per damper manufacturer UL testing.

Operation

Mounting of the actuator to the damper axle shaft or jackshaft is via a cold-weld clamp. Teeth in the clamp and V-bolt dig into the metal of both solid and hollow shafts maintaining a perfect connection. The specially designed clamp will not crush hollow shafts. The bottom end of the actuator is held by an anti-rotation strap or by a stud provided by the damper manufacturer. The actuator is mounted in its fail safe position with the damper blade(s) typically closed. Upon applying power, the actuator drives the damper to the open position. The internal spring is tensioned at the same time. If the power supply is interrupted, the spring moves the damper back to its fail-safe position.

Dimensions (Inches[mm])

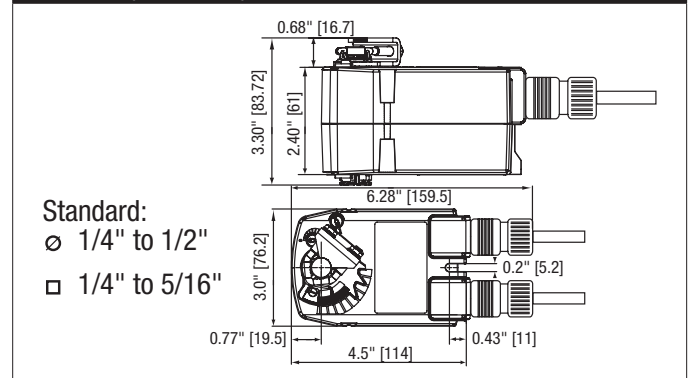

Standard:
 ∅ 1/4" to 1/2"
 □ 1/4" to 5/16"

Safety Notes

Screw a conduit fitting into the actuator's bushing. Jacket the actuator's input and output wiring with suitable flexible conduit. Properly terminate the conduit in a suitable junction box.

Retrofit Safety Note

Use of the FSTF for replacement of other makes of actuators is limited in damper area. The FSLF is preferred for direct coupled applications. The FSTF may be applied for linkage applications on dampers 1.5 sq.ft. and smaller at velocities under 2000 fpm.

Accessories	
KH-TF US	Crankarm for Shafts to 1/2"
KH-TF-1 US	Crankarm for Shafts with 1/4" slot
KH-TF-1.1 US	Crankarm for Shafts with 1/4" slot
TF-P	Anti-Rotation Bracket
TOOL-06	8 mm and 10 mm Wrench
ZDB-TF	Angle of Rotation Limiter for TF
ZG-TF2	Crankarm Adaptor Kit (includes mounting hardware)
ZG-TF3	TF mounting tubes and hardware kit
ZG-TF112	Crankarm Adaptor Kit (includes ZG-113 and KH-TF)
ZS-100	Weather Shield - Galvaneal
ZS-150	Weather Shield - Polycarbonate
BAE165 US	165°F electric thermal sensor. SPST, NC

Typical Specification

All smoke and combination fire and smoke dampers shall be provided with Belimo FSTF, FSLF, FSNF, or FSAF actuators. All substitutions must be approved before submission of bid. Damper and actuator shall have UL 555S Listing for 250°F &/or 350°F. Actuator shall have been tested to UL 2043 per requirements of IMC 602.2 and NEC 300.22 (c). Where position indication is required -S models with auxiliary switches or damper blade switches will be provided per code requirements.

Wiring Diagrams

- Provide overload protection and disconnect as required.
- Actuators may be powered in parallel. Power consumption must be observed.
- S4 makes to S6 when actuator is powered open.
- Auxiliary switches are for end position indication or interlock control.
- Double insulated.
- Ground present on some models.
- Meets cULus requirements without the need of an electrical ground connection.

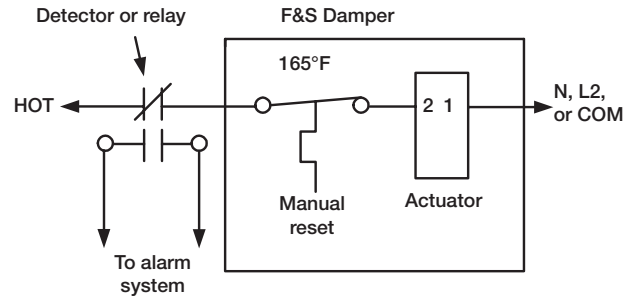
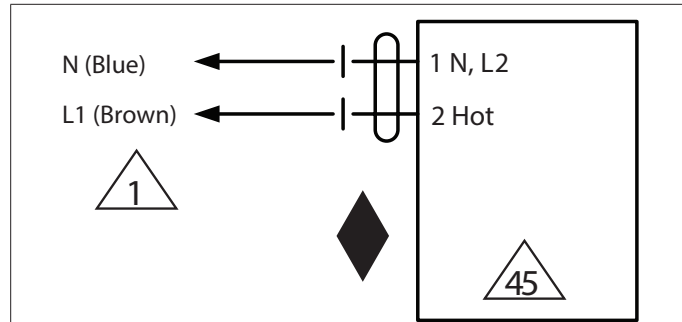

Typical containment damper control wiring

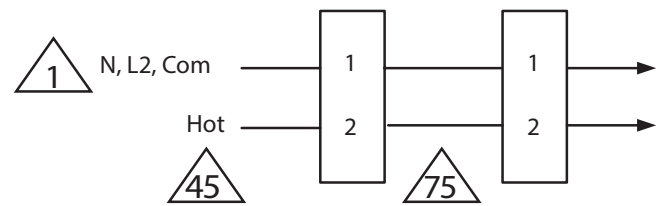

Parallel Actuator Wiring

