

Fire and smoke spring return actuators FSLF120 (-S) US, FSLF24 (-S) US



Fire and smoke actuator, 30 in-lb, [3.5 Nm], spring return, 350°F [177°C] for half hour, 15 sec. operation.



Technical Data	FSLF120(-S) US	FSLF24(-S) US
Nominal voltage	120 VAC 50/60 Hz	24 VAC 50/60 Hz
Nominal voltage range	108 - 132 VAC	21.6 - 26.4 VAC
Power consumption	Running: 24 VAC: 50/60 Hz: 5.0 VA 120 VAC, 60 Hz: 18 VA (120 VAC, 50 Hz: 20 VA) Holding: 24 VAC, 50/60 Hz: 3.5 VA 120 VAC, 60 Hz: 6.5 VA (120 VAC, 50 Hz: 12 VA)	
Transformer sizing 24 VAC	Safety note: Connect via safety isolating transformer, Class 2 supply.	
Electrical connection	18 ga, 3 color coded leads (120 V) 3 ft 18 ga, 2 color coded leads (24 V) 3 ft 3 ft, 18 ga, appliance cable (Aux switches)	
Overload protection	Electronic throughout 0 to 95° rotation Auto-restart after temporary overload	
Electrical protection motor	FSLF120 US grounded enclosure	
Electrical protection	Double insulated <input type="checkbox"/>	
Auxiliary switches		
Angle of rotation	95°	
Torque	30 in-lb [3.5 Nm] minimum from 32°F to 350°F [0°C to 177°C]	
Direction of rotation	Spring return can be selected by CCW/CW mounting	
Position indication	Visual indicator, 0° to 95°	
Running time	Motor: < 15 sec at rated voltage and torque 32°F to +122°F [0°C to +50°C] Spring: < 15 sec at ambient	
Control	Microprocessor	
Auxiliary switches FSLF120-S US/24-S US	2 x SPST 0.5 A inductive @ 120/250 V, 1 mA @ 5 VDC, 3 A resistive @ 120/250 V, UL listed, 10° and 85°	
Humidity	5 to 95% RH noncondensing	
Ambient temperature		
- Normal operation	32°F to +122°F [0°C to +50°C]	
- Safety operation	3 On/Off cycles after 30 minutes at ambient temperature of 350°F [177°C]	
Storage temperature	-40°F to +176°F [-40°C to +80°C]	
Housing	NEMA type 1, zinc coated steel	
Type of action	Type 1.B Software class A	
Shaft	3/8"-1/2" md (7/16" sq) 1/2"-3/4" rnd w/K6-1	
Gears	Permanently lubricated	
Agency listings	cULus listed to UL 60730-1 and CAN/CSA 22.2 No 4.	
Servicing	Maintenance free	
Quality standard	ISO 9001	
Weight 24, 120, (-S) [kg]	3.4 lbs [1.7], 4 lb [1.8], +3 lb [+1.4]	

Application:

The type FSLF spring-return actuator is intended for the operation of smoke and combination fire and smoke dampers in ventilation and air-conditioning systems. The actuator will meet requirements of UL555 and UL555S when tested as an assembly with the damper and will meet requirements of UBC for 15 second opening and closing.

Square footage of damper operated will depend on make and model and the temperature required.

Operation

Mounting of the actuator to the damper axle shaft or jackshaft is via a cold-weld clamp. Teeth in the clamp and V-bolt dig into the metal of both solid and hollow shafts maintaining a perfect connection. The specially designed clamp will not crush hollow shafts. The bottom end of the actuator is held by an anti-rotation strap or by a stud provided by the damper manufacturer.

The actuator is mounted in its fail safe position with the damper blade(s) closed. Upon applying power, the actuator drives the damper to the open position. The internal spring is tensioned at the same time. If the power supply is interrupted, the spring moves the damper back to its fail-safe position.

Safety note:

The actuator contains no components which the user can replace or repair.



Wiring Diagram

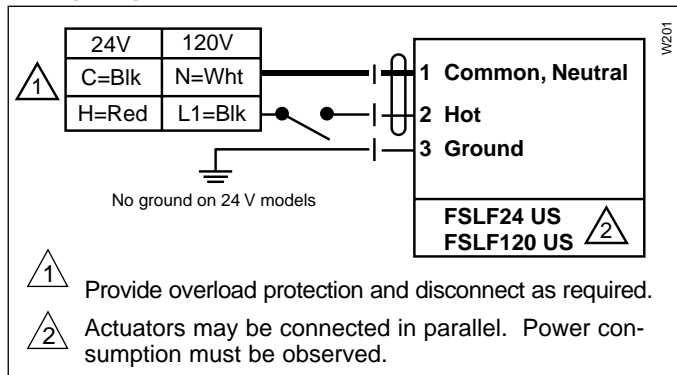

Dimensions (All ratings in brackets are metric.)

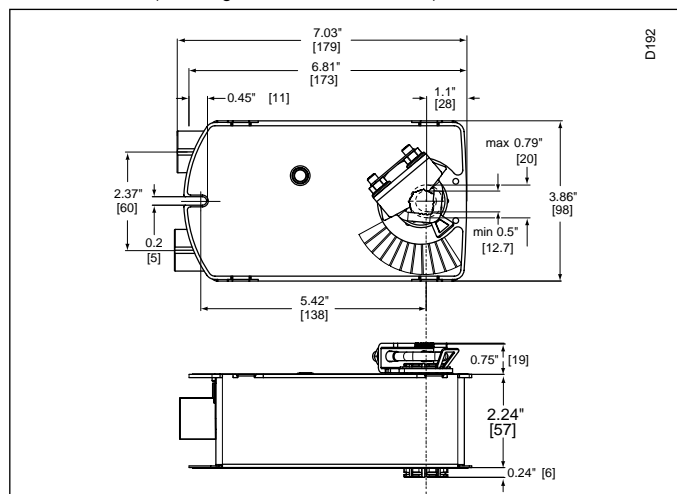

Multi-section Damper Assemblies – Typical Applications

The typical fire and smoke damper requires from 5-15 in-lb of torque per square foot at 250°F - 350°F under dynamic load

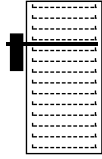

Single section for one FSLF actuator

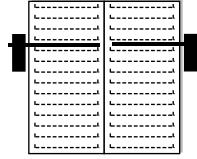

Two section for two FSLF actuators

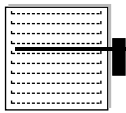

Maximum area one actuator

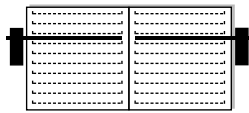

Maximum area for two actuators

(2000 fpm velocity). The FSLF is a single section damper actuator. For the multi section dampers, use the FSNF series.

This is a direct coupled actuator. If linkages are needed use the FSNF series. Square shaft adaptors are available: 22153-00002, 22153-00003, 22513-00004 for the 8mm, 10mm, and 12mm, form fit respectively.

Safety note:

1/2" Threaded Connector

Screw a conduit fitting into the actuator's metal bushing. Jacket the actuator's input wiring with suitable flexible conduit. Properly terminate the conduit in a suitable junction box.

3/8" Flex Connector (-FC models)

Mount the flexible conduit into the actuator's metal bushing by means of the provided screw with a torque of 1.2 Nm. Jacket the actuator's input wiring with suitable flexible conduit. Properly terminate the conduit in a suitable junction box.

Parallel actuator wiring

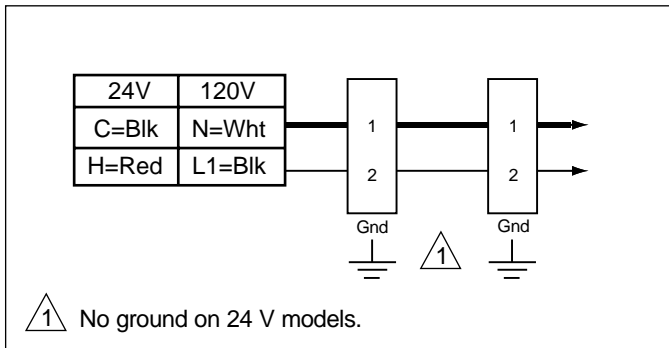

Auxiliary switch wiring for FSLF24-S US, FSLF120-S US

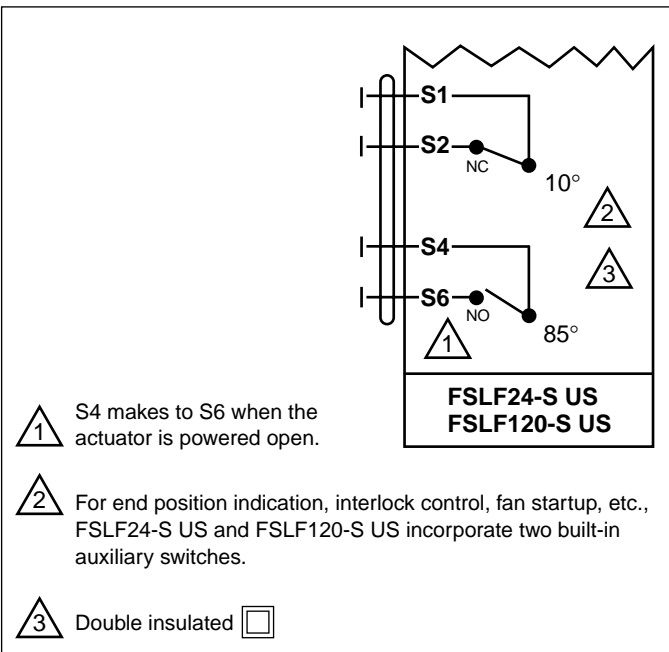

Typical Specification

Smoke Control and Combination Fire and Smoke Control Damper Actuators

All smoke and combination fire and smoke dampers shall be provided with Belimo FSLF, FSNF, or FSAF actuators. No substitutions allowed.

Damper and actuator shall have UL555S Listing for 250°F (350°F) and shall comply with UBC if required by local codes.

Where proof of closure switches are required, blade switches, actuator auxiliary switches, or proximity switches are allowed.

Replacement Applications

The number one "equal or better" requirement for use as a replacement for obsolete defective motors is the UL555S listing of the Belimo actuator with the damper for the application. The local authority having jurisdiction sets the requirements.

Contact Belimo for a list of damper manufacturers with UL555S listing with Belimo FSAF, FSNF, & FSLF actuators.

Caution must be used when replacing failed motors with new Belimo actuators. Many old motors did not have internal springs and depended on external springs on the side of the damper or wrapped around the damper shaft to close the damper.

In some cases, the damper must be replaced because the damper would have to undergo major modifications to replace an actuator.

Most codes require that "equal or better" actuators be used to replace defectives.