

EV200S-761 Technical Data Sheet

Stainless Steel Ball and Stem, Female NPT Ends

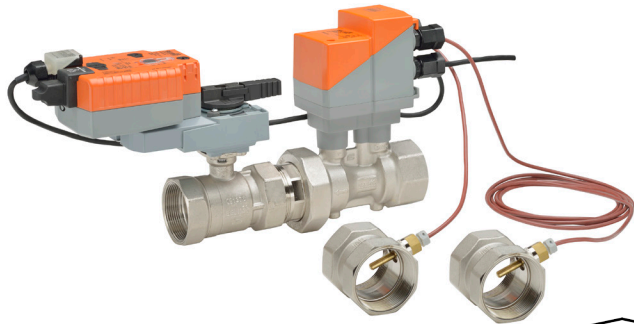

Technical Data

Fluid	chilled or hot water, up to 60% glycol max (open loop/steam not allowed)
Flow characteristic	equal percentage or linear
GPM Range	22.8-76.1
Valve Size [mm]	2" [50]
Pipe connection	NPT female ends
Housing	Nickel-plated brass body
Flow measuring pipe	brass body nickel-plated
Ball	stainless steel
Stem	stainless steel
Stem seal	EPDM (lubricated)
Seat	PTFE
O-ring	EPDM
Characterized disc	TEFZEL®
Body Pressure Rating	360 psi
Differential Pressure Range	5...50 psi or 1...50 psi see flow reductions chart in tech doc
Close-off pressure Δps	200 psi
Inlet Length to Meet Specified Measurement Accuracy	5X nominal pipe size (NPS)
Ambient humidity	max. 95% r.H., non-condensing
Measuring accuracy flow	±2%*
Control accuracy	±5%
Flow Measurement Repeatability	±0.5%
Sensor Technology	ultrasonic with glycol and temperature compensation
Temperature Sensors	Pt1000 insertion sensors
Temperature Measurement Tolerance	According to Pt1000 DIN EN60751 Class B
Resolution of Temperature Sensor	0.18°F [0.1°C]
Rated impulse voltage supply	actuator/sensor: 0.8 kV (in accordance with EN60730-1) kV
Rangeability Sv	100:1
Degree of Protection	NEMA 1, UL Enclosure Type 1
Weight	13.23 lb [6.0 kg]
Remote Temperature Sensor Length	Standard: 2 ft. 7.5 in. [0.8m], 9.8 ft. [3m]
Fluid Temp Range (water)	14...250°F [-10...120°C]
Leakage rate	0%
Glycol Measurement Accuracy	±5%

*All flow tolerances are at 68°F (20°C) & water.

Application

Water-side control of heating and cooling systems for AHUs and water coils. Equal Percentage/ Linear: heating and cooling applications.

Operation

The Energy Valve is an energy metering pressure independent control valve that measures, documents and optimises water coil performance.

Product Features

The Energy Valve measures energy using its built-in electronic flow sensor and supply and return temperature sensors. Controls power with its power control logic providing linear heat transfer regardless of temperature and pressure variations. Manages low delta-T with its built in Delta-T manager. Measures glycol with advanced algorithms in its built in flow sensor. An IoT device utilising cloud-based technology to optimise performance.

Suitable Actuators

	Non-Spring	Electronic fail-safe
EV200S-761	ARB(X)	(AKRB(X))

Dimensions (Inches [mm])

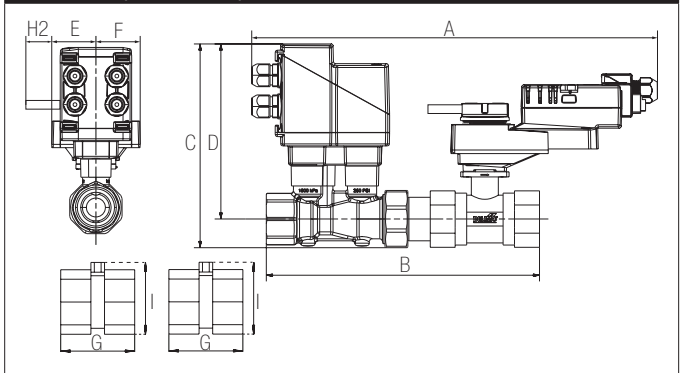

A	B	C	D	E	F	G	H2	I
17.1" [435]	11.2" [284]	8.3" [211]	7.0" [179]	1.7" [44]		3.1" [80]	0.8" [20]	4.1" [105]

Safety Notes

WARNING: This product can expose you to lead which is known to the State of California to cause cancer and reproductive harm. For more information go to www.p65warnings.ca.gov

AKRX24-EV Technical Data Sheet

Modulating, Electronic Fail-Safe, 24 V, Shared Logic Technology®



5-year warranty



Technical Data	
Power Supply	24 VAC, ±20%, 50/60 Hz, 24 VDC, ±10%
Power consumption in operation	14 W (0.5" to 2"), 16 W (2.5" to 6")
Transformer sizing	23 VA (0.5...2"), 26 VA (2.5...6") (class 2 power source)
Electrical Connection	18 GA plenum cable and RJ45 socket (ethernet)
Overload Protection	electronic throughout 0...90° rotation
Operating Range	2...10 V (default), 4...20 mA w/ ZG-R01 (500 Ω, 1/4 W resistor), VDC variable
Input Impedance	100 kΩ (0.1 mA), 500 Ω
Position Feedback	default 2...10 V, VDC variable
Angle of rotation	90°
Direction of motion motor	reversible with web view
Direction of motion fail-safe	reversible with switch
Position indication	Mechanically, pluggable
Manual override	external push button
Running Time (Motor)	90 s
Running time fail-safe	<35 s
Ambient humidity	max. 95% r.H., non-condensing
Ambient temperature	-22...122°F [-30...50°C] (ultrasonic sensor), 14...122°F [-10...50°C] (electro-magnetic sensor)
Storage temperature	-40...176°F [-40...80°C]
Degree of Protection	IP54, NEMA 1, UL Enclosure Type 1
Housing material	UL94-5VA
Agency Listing	cULus acc. to UL60730-1A/-2-14, CAN/CSA E60730-1:02, CE acc. to 2014/30/EU and 2014/35/EU
Noise level, motor	45 dB(A)
Noise level, fail-safe	45 dB(A)
Servicing	maintenance-free
Quality Standard	ISO 9001
Weight	1.94 lb [1.5 kg]
Communication	BACnet IP BACnet MS/TP Modbus RTU Modbus TCP MP-Bus

The Energy Valve is based on Belimo patent and patent pending technology, US-Patent 6,039,304: ball valve with modified characteristics, US-Patent Pending: 2011/0153089: HVAC actuator comprising a network interface, data store and a processor, US-Patent Pending: 2009/009115: control of sensor less and brushless DC-Motor.

The Energy Valve incorporates additional technology - powered by Optimum Energy TM.

Date created, 04/24/2020 - Subject to change. © Belimo Aircontrols (USA), Inc.

Wiring Diagrams

✂ INSTALLATION NOTES

- A Actuators with appliance cables are numbered.
- 2 Actuators may be connected in parallel. Power consumption and input impedance must be observed.
- 3 Actuators may also be powered by 24 VDC.
- 18 Actuators with plenum cable do not have numbers; use color codes instead.
- Meets cULus requirements without the need of an electrical ground connection.

⚠ WARNING! LIVE ELECTRICAL COMPONENTS!
 During installation, testing, servicing and troubleshooting of this product, it may be necessary to work with live electrical components. Have a qualified licensed electrician or other individual who has been properly trained in handling live electrical components perform these tasks. Failure to follow all electrical safety precautions when exposed to live electrical components could result in death or serious injury.

