

B209 Technical Data Sheet

Stainless Steel Ball and Stem

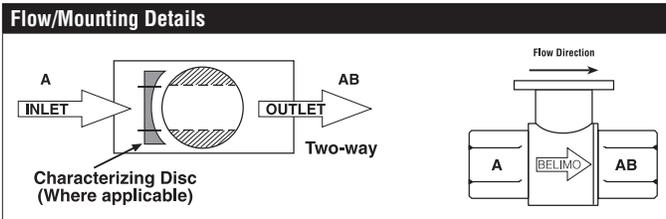

Technical Data	
Fluid	chilled, hot water, up to 60% glycol
Flow characteristic	equal percentage
Controllable flow range	75°
Valve Size [mm]	0.5" [15]
Pipe connection	NPT female ends
Housing	Nickel-plated brass body
Ball	stainless steel
Stem	stainless steel
Stem seal	EPDM (lubricated)
Seat	PTFE
O-ring	EPDM (lubricated)
Characterised disc	TEFZEL®
Body Pressure Rating	600 psi
Close-off pressure Δps	200 psi
Cv	0.8
Weight	0.44 lb [0.20 kg]
Fluid Temp Range (water)	0...250°F [-18...120°C]
Leakage rate	0% for A – AB
Maintenance	maintenance-free



Application

This valve is typically used in air handling units on heating or cooling coils, and fan coil unit heating or cooling coils. Some other common applications include Unit Ventilators, VAV box re-heat coils and bypass loops. This valve is suitable for use in a hydronic system with variable flow.

Suitable Actuators

	Non-Spring	Spring
B209	TR, LRB(X), NR	TFRB(X), LF

Dimensions (Inches [mm])

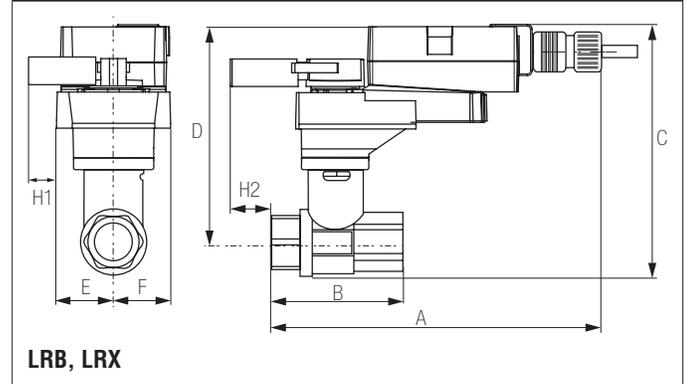

A	B	C	D	E	F	H1	H2
9.4" [239]	2.4" [60]	5.2" [132]	4.6" [117]	1.3" [33]		1.2" [30]	1.1" [28]

Safety Notes

WARNING: For Belimo products sold in California: these products do or may contain chemicals which are known to the State of California to cause cancer and or birth defects or other reproductive harms. For more information see www.p65warnings.ca.gov.

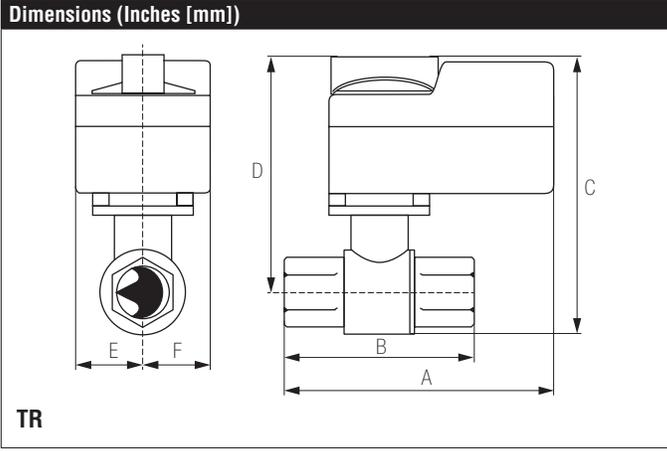

A	B	C	D	E	F
3.7" [95]	2.4" [60]	4.8" [122]	4.2" [107]	1.3" [33]	

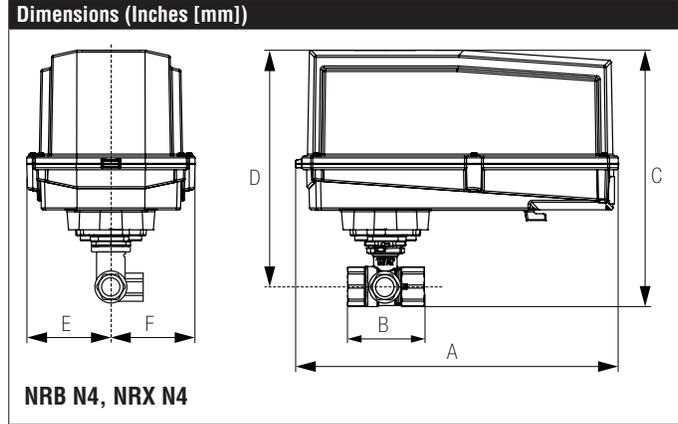

A	B	C	D	E	F
11.4" [289]	2.4" [60]	7.7" [196]	7.0" [179]	3.1" [80]	

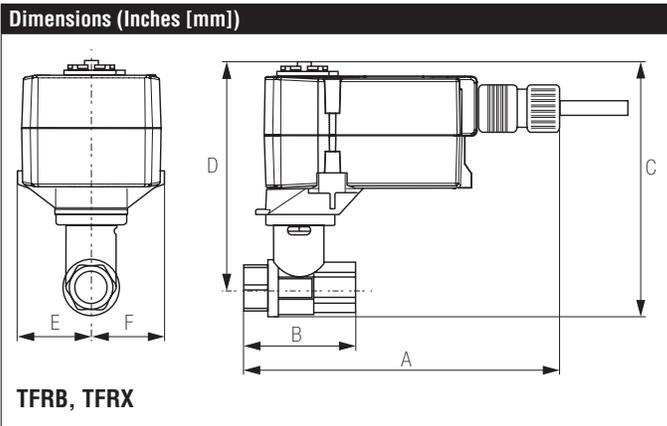

A	B	C	D	E	F
6.6" [167]	2.4" [60]	4.9" [124]	4.3" [110]	1.5" [39]	

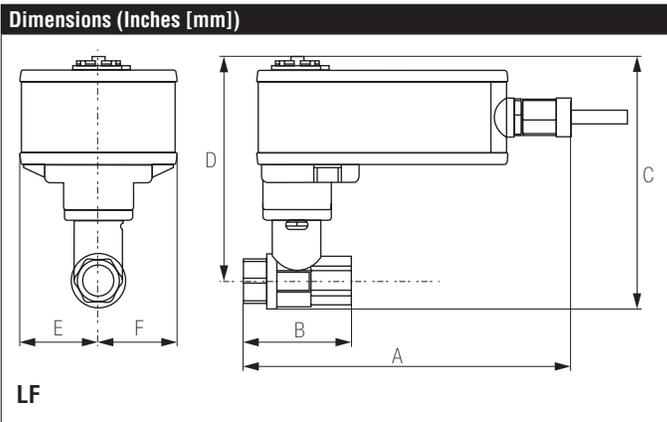

A	B	C	D	E	F
7.9" [200]	2.4" [60]	5.7" [146]	5.1" [129]	1.8" [46]	



Models

TR24-3-T US	
TR24-3 US	TR24-3-T US with 3 ft plenum rated cable
TR24-3/300 US	TR24-3-T US with 10 ft plenum rated cable
TR24-3/500 US	TR24-3-T US with 16 ft plenum rated cable

Technical Data

Control	On/Off, Floating Point
Nominal voltage	24 VAC 50/60 Hz
Nominal voltage range	19.2...28.8 VAC
Power consumption	1 W
Transformer sizing	1VA (class 2 power source)
Electrical connection	screw terminals accessible after removal of small cover (3 ft, 10 ft, 16 ft cables optional)
Input impedance	.36 kΩ
Angle of rotation	90°
Position indication	integrated into handle
Manual override	push down handle
Running time	90 seconds @ 60 hz, 108 seconds @ 50 hz
Humidity	5 to 95% non-condensing
Ambient temperature	-22°F to 122°F (-30°C to 50°C)
Storage temperature	-40°F to 176°F (-40°C to 80°C)
Housing	NEMA 1/IP40
Housing rating	UL94-5V(B)
Agency listing†	cULus acc. to UL60730-1A/-2-14, CAN/GSA E60730-1, CSA C22.2 No. 24-93, CE acc. to 89/336/EEC
Noise level	Max. 35 db (A)
Quality standard	ISO 9001

† Rated impulse voltage 330V, Control pollution degree 2, Type of action 1

Dimensions with 2-Way Valve

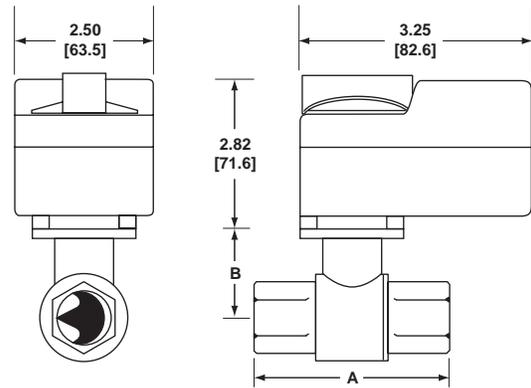

D069

Valve Body	Valve Nominal Size		Dimensions (Inches [mm])	
	Inches	DN [mm]	A	B
B207(B)-B211(B)	½"	15	2.41" [61.1]	1.39" [35.2]
B212(B)-B215(B)	½"	15	2.38" [60.4]	1.72" [43.7]
B217(B)-B220(B)	¾"	20	2.73" [69.3]	1.81" [45.9]

Dimensions with 3-Way Valve

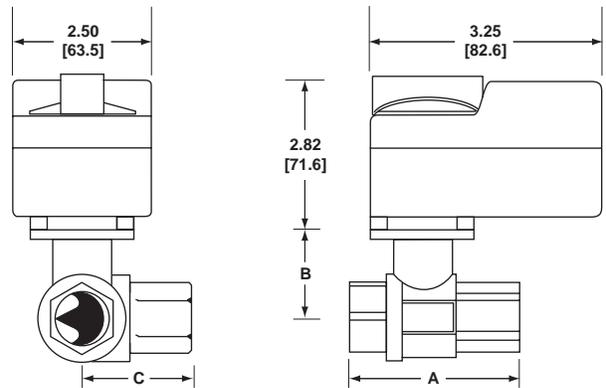

D072

Valve Body	Valve Nominal Size		Dimensions (Inches [mm])		
	Inches	DN [mm]	A	B	C
B307(B)-B311(B)	½"	15	2.41" [61.1]	1.39" [35.2]	1.20" [30.6]
B312(B)-B315(B)	½"	15	2.38" [60.4]	1.72" [43.7]	1.26" [32.1]
B317(B)-B320(B)	¾"	20	2.73" [69.3]	1.81" [45.9]	1.45" [36.8]

Wiring Diagrams

✂ INSTALLATION NOTES

- 2 The common connection from the actuator must be connected to the Hot connection of the controller.
- 3 Actuators with plenum rated cable do not have numbers on wires; use color codes instead.
- 4 The actuator Hot must be connected to the control board Hot.

⚠ WARNING Live Electrical Components!
 During installation, testing, servicing and troubleshooting of this product, it may be necessary to work with live electrical components. Have a qualified licensed electrician or other individual who has been properly trained in handling live electrical components perform these tasks. Failure to follow all electrical safety precautions when exposed to live electrical components could result in death or serious injury.

NOTE: TR24-3(-T) US cannot be wired in parallel with themselves or any other actuator.

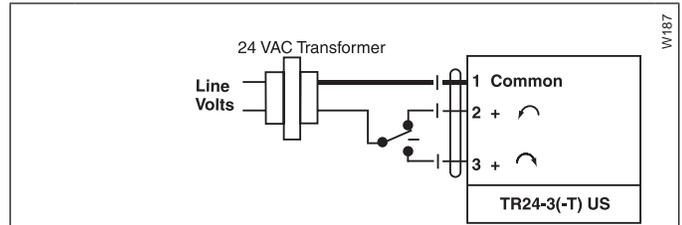

Floating Control

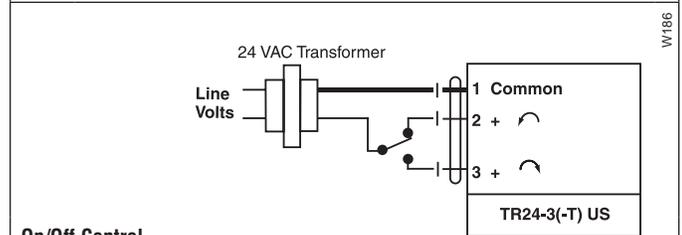

On/Off Control

You may not use one wire control.

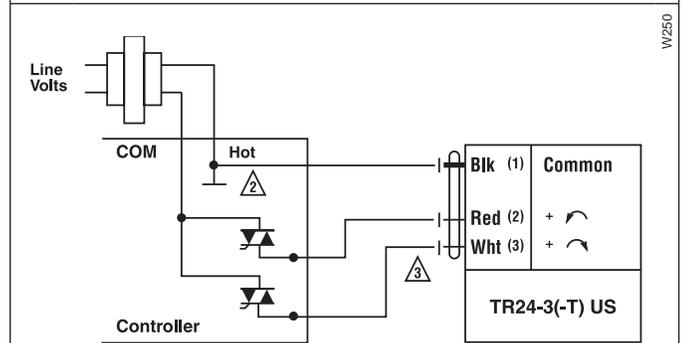

Triac Sink

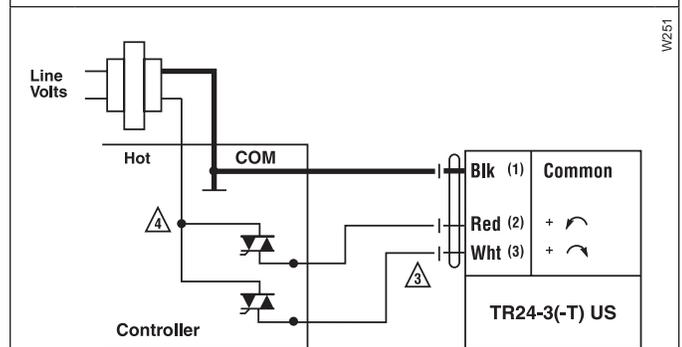

Triac Source