

AMX24-3 Technical Data Sheet

On/Off, Floating Point, Non-Spring Return, 24 V



Technical Data	
Power Supply	24 VAC, ±20%, 50/60 Hz, 24 VDC, ±10%
Power consumption in operation	2.5 W
Power consumption in rest position	0.5 W
Transformer sizing	5.5 VA (class 2 power source)
Shaft Diameter	1/2...1.05" round, centers on 1/2" and 3/4" with insert, 1.05" without insert
Electrical Connection	18 GA plenum cable, 3 ft [1 m], with 1/2" conduit connector, degree of protection NEMA 2 / IP54
Overload Protection	electronic throughout 0...95° rotation
Input Impedance	600 Ω
Angle of rotation	Max. 95°, adjustable with mechanical stop
Torque motor	180 in-lb [20 Nm]
Direction of motion motor	selectable with switch 0/1
Position indication	Mechanically, 30...65 mm stroke
Manual override	external push button
Running Time (Motor)	90 s, constant, independent of load
Ambient humidity	max. 95% r.H., non-condensing
Ambient temperature	-22...122°F [-30...50°C]
Storage temperature	-40...176°F [-40...80°C]
Degree of Protection	IP54, NEMA 2, UL Enclosure Type 2
Housing material	UL94-5VA
Agency Listing	cULus acc. to UL60730-1A/-2-14, CAN/CSA E60730-1:02, CE acc. to 2014/30/EU and 2014/35/EU
Noise level, motor	45 dB(A)
Servicing	maintenance-free
Quality Standard	ISO 9001
Weight	1.4 lb [0.64 kg]

†Rated Impulse Voltage 800V, Type action 1.B, Control Pollution Degree 3.

Torque min. 180 in-lb, for control of damper surfaces up to 45 sq. ft.

Application

For on/off and floating point control of dampers in HVAC systems. Actuator sizing should be done in accordance with the damper manufacturer's specifications.

The actuator is mounted directly to a damper shaft up to 1.05" in diameter by means of its universal clamp, self-centered default. A crank arm and several mounting brackets are available for applications where the actuator cannot be direct coupled to the damper shaft.

Operation

The actuator is not provided with and does not require any limit switches, but is electronically protected against overload. The anti-rotation strap supplied with the actuator will prevent lateral movement. The actuator provides 95° of rotation and a visual indicator indicates position of the actuator. When reaching the damper or actuator end position, the actuator automatically stops. The gears can be manually disengaged with a button on the actuator cover. The actuators use a sensorless brushless DC motor, which is controlled by an Application Specific Integrated Circuit (ASIC). The ASIC monitors and controls the actuator's rotation and provides a digital rotation sensing (DRS) function to prevent damage to the actuator in a stall condition. Power consumption is reduced in holding mode. The -S version is provided with 1 built-in auxiliary switch. This SPDT switch is provided for safety interfacing or signaling, for example, for fan start-up. The switching function is adjustable 0 to 95°. The auxiliary switch is double insulated so an electrical ground connection is not necessary. Add-on auxiliary switches or feedback potentiometers are easily fastened directly onto the actuator body for signaling and switching functions.

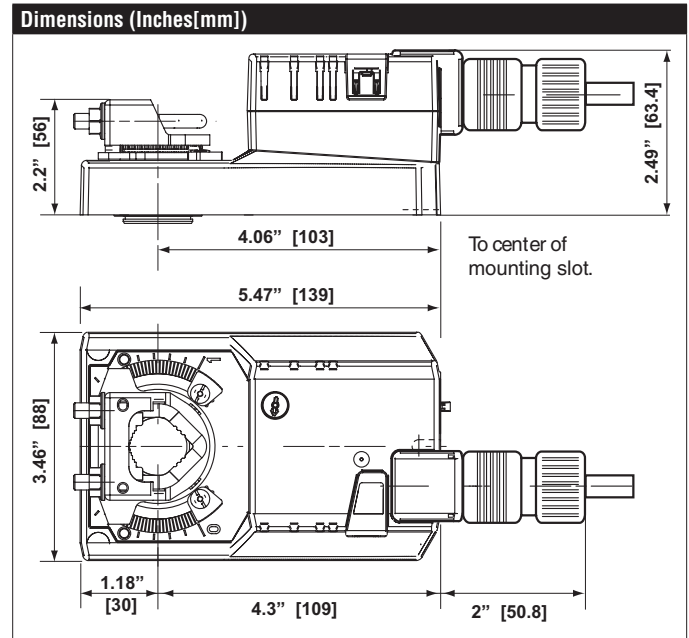

Date created, 02/10/2020 - Subject to change. © Belimo Aircontrols (USA), Inc.

Typical Specification

Floating point, on/off control damper actuators shall be electronic direct-coupled type, which require no crank arm and linkage and be capable of direct mounting to a shaft up to 1.05" diameter. Actuators shall have brushless DC motor technology and be protected from overload at all angles of rotation. Actuators shall have reversing switch and manual override on the cover. If required, actuators shall be provided with one adjustable SPDT auxiliary switch. Actuators with auxiliary switches must be constructed to meet the requirements for double insulation so an electrical ground is not required to meet agency listings. If required, actuators will be provided with a screw terminal strip for electrical connections (AMX24-3-T). Run time shall be constant and independent of torque. Actuators shall be cULus listed, have a 5-year warranty, and be manufactured under ISO 9001 International Quality Control Standards. Actuators shall be as manufactured by Belimo.

Wiring Diagrams

- Actuators with appliance cables are numbered.
- Provide overload protection and disconnect as required.
- Actuators may also be powered by 24 VDC.
- Actuators Hot wire must be connected to the control board common. Only connect common to neg. (-) leg of control circuits. Terminal models (-T) have no-feedback.
- Actuators may be connected in parallel if not mechanically linked. Power consumption and input impedance must be observed.

