

AMB24-MFT Technical Data Sheet

Modulating, Non-Spring Return, 24 V, Multi-Function Technology®



Technical Data

Power Supply	24 VAC, ±20%, 50/60 Hz, 24 VDC, ±10%
Power consumption in operation	3.5 W
Power consumption in rest position	1.3 W
Transformer sizing	6 VA (class 2 power source)
Shaft Diameter	1/2...1.05" round, centers on 1/2" and 3/4" with insert, 1.05" without insert
Electrical Connection	18 GA plenum cable, 3 ft [1 m], with 1/2" conduit connector, degree of protection NEMA 2 / IP54
Overload Protection	electronic throughout 0...95° rotation
Operating Range	2...10 V (default), 4...20 mA w/ ZG-R01 (500 Ω, 1/4 W resistor), variable (VDC, PWM, on/off, floating point)
Operating range Y variable	Start point 0.5...30 V End point 2.5...32 V
Input Impedance	100 kΩ for 2...10 V (0.1 mA), 500 Ω for 4...20 mA, 1500 Ω for PWM, On/Off and Floating point
Position Feedback	2...10 V, Max. 0.5 mA, VDC variable
Angle of rotation	Max. 95°, adjustable with mechanical stop
Torque motor	180 in-lb [20 Nm]
Direction of motion motor	selectable with switch 0/1
Position indication	Mechanically, 30...65 mm stroke
Manual override	external push button
Running Time (Motor)	default 150 s, variable 90...350 s
Ambient humidity	max. 95% r.H., non-condensing
Ambient temperature	-22...122°F [-30...50°C]
Storage temperature	-40...176°F [-40...80°C]
Degree of Protection	IP54, NEMA 2, UL Enclosure Type 2
Housing material	UL94-5VA
Agency Listing	cULus acc. to UL60730-1A/-2-14, CAN/CSA E60730-1:02, CE acc. to 2014/30/EU and 2014/35/EU
Noise level, motor	45 dB(A)
Servicing	maintenance-free
Quality Standard	ISO 9001
Weight	2.5 lb [1.2 kg]

†Rated Impulse Voltage 800V, Type action 1, Control Pollution Degree 3.

Torque min. 180 in-lb, for control of damper surfaces up to 45 sq. ft.

Application

For proportional modulation of dampers in HVAC systems. Actuator sizing should be done in accordance with the damper manufacturer's specifications.

The actuator is mounted directly to a damper shaft up to 1.05" in diameter by means of its universal clamp. A crank arm and several mounting brackets are available for applications where the actuator cannot be direct coupled to the damper shaft.

The default parameters for 2 to 10 VDC applications of the ...MFT actuator are assigned during manufacturing. If necessary, custom versions of the actuators can be ordered. The parameters can be changed by two means: pre-set and custom configurations from Belimo or on-site configurations using the Belimo PC-Tool software.

Operation

The actuator is not provided with and does not require any limit switches, but is electronically protected against overload. The anti-rotation strap supplied with the actuator will prevent lateral movement.

The actuator provides 95° of rotation and a visual indicator indicates position of the actuator. When reaching the damper or actuator end position, the actuator automatically stops. The gears can be manually disengaged with a button on the actuator cover.

The actuators use a brushless DC motor, which is controlled by an Application Specific Integrated Circuit (ASIC). The ASIC monitors and controls the actuator's rotation and provides a digital rotation sensing (DRS) function to prevent damage to the actuator in a stall condition. Power consumption is reduced in holding mode.

Add-on auxiliary switches or feedback potentiometers are easily fastened directly onto the actuator body for signaling and switching functions.

For low ambient temperatures, the optional supplemental (-H) Heater add-on is available.

Dimensions (Inches[mm])

∅ 1/2" to 1.05" [12.7 to 26.67]

□ 2/5" to 1.05" [10 to 26.67]

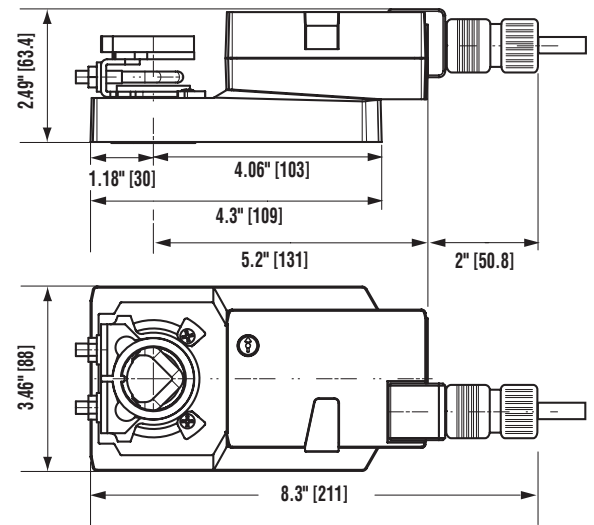

KG8	Ball joint
KG10A	Ball joint
SH8	Push rod for KG6 & KG8 ball joints (36" L, 5/16" diameter).
SH10A	Push rod for KG10A ball joint (36" L, 3/8" diameter).
ZG-DC1	Damper clip for damper blade, 3.5" width.
ZG-DC2	Damper clip for damper blade, 6" width.
ZS-100	Weather shield - polyurea 12x8x6" (LxWxD)
Accessories	
ZS-101	Base plate for ZS-100.
ZS-150	Weather shield - PC w/ foam seal 16x8-3/8x4" (LxWxD).
AV8-25	Shaft extension
TF-P	Anti-rotation bracket TF/NKQ/AM/NM/LM.
ZG-100	Univ. right angle bracket 17"x11-1/8"x6" (HxWxbase).
ZG-101	Univ. right angle bracket 13x11x7-7/16" (HxWxbase).
TOOL-06	8 mm and 10 mm wrench.
Z-SPA	Adapter
PS-100	Low voltage and control signal simulator.
AH-25	Actuator arm
K-AM25	Standard NKQ/AM/NM clamp (1/2" to 1.05").
K-SA	Shaft clamp reversible
ZG-109	Right angle bracket for ZS-260.
ZG-110	Stand-off bracket for ZS-260.
ZG-112	LF right angle bracket 4-1/2x5-1/2x2-1/2" (HxWxD).
ZG-JSA-1	1" diameter jackshaft adaptor (11" L).
ZG-JSA-2	1-5/16" diameter jackshaft adaptor (12" L).
ZG-JSA-3	1.05" diameter jackshaft adaptor (12" L).
ZG-NMA	Mounting kit for linkage operation
ZS-260	Explosion proof housing.
ZS-300	NEMA 4X, 304 stainless steel enclosure.
ZS-300-5	NEMA 4X, 316L stainless steel enclosure.
ZS-300-C1	1/2" shaft adaptor, standard with ZS-300(-5).
ZS-300-C2	3/4" shaft adaptor for ZS-300(-5).
ZS-300-C3	1" shaft adaptor for ZS-300(-5).
Z-SMA	Base plate extension
ZTH US	Handheld programming tool w/ ZK1-GEN, ZK2-GEN, ZK6-GEN.
UK24LON	Gateway MP to LonWorks
UK24BAC	Gateway MP to BACnet MS/TP
UK24MOD	Gateway MP to Modbus RTU
ZG-SGF	Mounting plate for SGF.
ZG-SGF	Mounting plate for SGF.
S1A	Auxiliary switch for damper actuators and rotary actuators
S2A	Auxiliary switch for damper actuators and rotary actuators
P475	Shaft mount, non-Mercury aux. switch for 1/2" dia. shafts.
P475-1	Shaft mount, non-Mercury aux. switch for 1" dia. shafts.
P140A GR	Feedback potentiometer for damper actuators and rotary actuators
P500A GR	Feedback potentiometer for damper actuators and rotary actuators
P1000A GR	Feedback potentiometer for damper actuators and rotary actuators
P2800A GR	Feedback potentiometer for damper actuators and rotary actuators
P5000A GR	Feedback potentiometer for damper actuators and rotary actuators
P10000A GR	Feedback potentiometer for damper actuators and rotary actuators
NSV24 US	Battery back-up module for non-spring return actuators.
NSV-BAT	12V 1.2AH battery (two required for NSV24 US).
ZG-X40	120 to 24 VAC, 40 VA transformer.
TF-CC US	Cable conduit connector, 1/2".
43442-00001	Cable gland (for NEMA 4 models).
ZK1-GEN	Connection cable
ZK2-GEN	Connection cable
SGA24	Positioners suitable for use with the modulating damper actuators LM..A-SR, NM..A-SR, SM..A-SR and GM..A-SR
SGF24	Positioners suitable for use with the modulating damper actuators LM..A-SR, NM..A-SR, SM..A-SR and GM..A-SR
IRM-100	Input rescaling module for modulating actuators.
ZG-R01	4 to 20 mA adaptor, 500Ω, 1/4 W resistor w 6" pigtail wires.

AMB24-MFT Technical Data Sheet

Modulating, Non-Spring Return, 24 V, Multi-Function Technology®

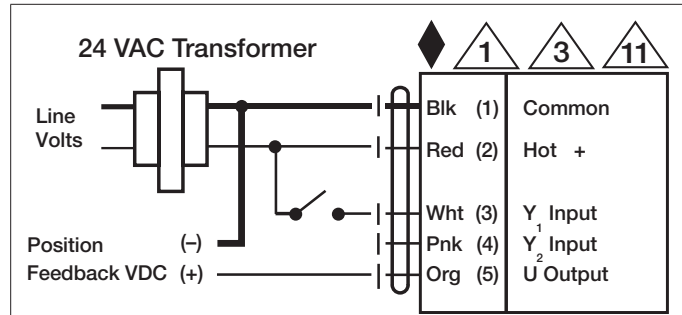

On/Off

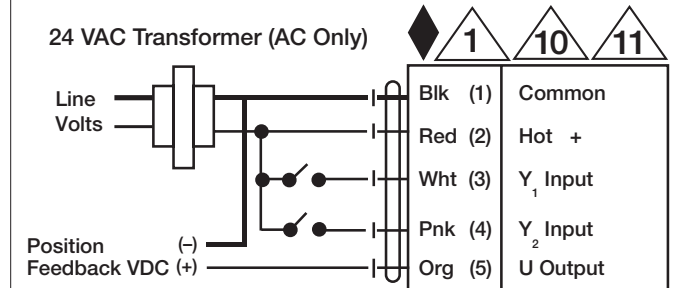

Floating Point

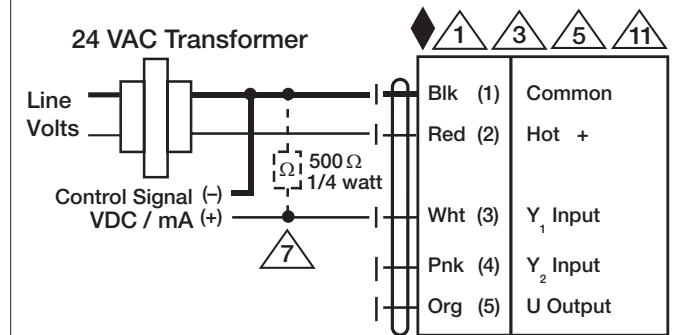

VDC/mA Control

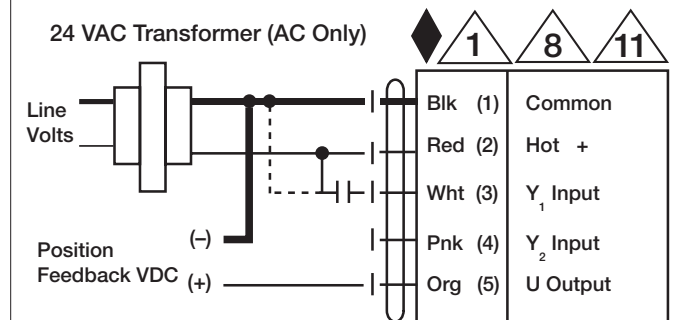

PWM Control

Date created, 02/10/2020 - Subject to change. © Belimo Aircontrols (USA), Inc.

AMB24-MFT Technical Data Sheet

Modulating, Non-Spring Return, 24 V, Multi-Function Technology®



Typical Specification

Modulating control damper actuators shall be electronic direct-coupled type, which require no crank arm and linkage and be capable of direct mounting to a shaft up to 3/4" diameter. Actuators must provide proportional damper control in response to a 2 to 10 VDC or, with the addition of a 500 Ω resistor, a 4 to 20 mA control input from an electronic controller or positioner. Actuators shall have brushless DC motor technology and be protected from overload at all angles of rotation. Run time shall be constant and independent of torque. A 2 to 10 VDC feedback signal shall be provided for position indication. Actuators shall be cULus listed, NEMA 4X, have a 5-year warranty, and be manufactured under ISO 9001 International Quality Control Standards. Actuators shall be as manufactured by Belimo.

Wiring Diagrams

- (A) Actuators with appliance cables are numbered.
- 1 Provide overload protection and disconnect as required.
- 3 Actuators may also be powered by 24 VDC.
- 5 Only connect common to negative (-) leg of control circuits.
- 7 A 500 Ω resistor (ZG-R01) converts the 4 to 20 mA control signal to 2 to 10 VDC.
- 8 Control signal may be pulsed from either the Hot (Source) or Common (Sink) 24 VAC line.
- 10 For triac sink the Common connection from the actuator must be connected to the Hot connection of the controller. Position feedback cannot be used with a triac sink controller; the actuator internal common reference is not compatible.
- 11 Actuators may be connected in parallel if not mechanically linked. Power consumption and input impedance must be observed.
- 12 IN4004 or IN4007 diode. (IN4007 supplied, Belimo part number 40155).

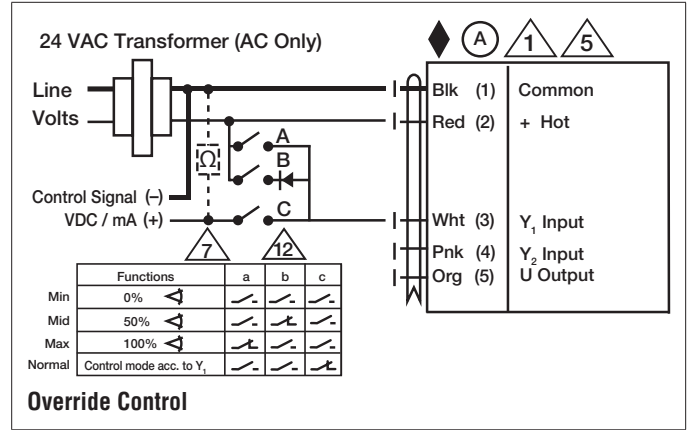

Date created, 02/10/2020 - Subject to change. © Belimo Aircontrols (USA), Inc.