

AHB24-SR-100 Technical Data Sheet

Modulating, Non-Spring Return, Linear, 24 V, for DC 2...10 V or 4...20 mA



Technical Data

Power Supply	24 VAC, ±20%, 50/60 Hz, 24 VDC, ±20%
Power consumption in operation	2.5 W
Power consumption in rest position	0.5 W
Transformer sizing	4.5 VA (class 2 power source)
Electrical Connection	18 GA plenum cable, 3 ft [1 m], with 1/2" conduit connector
Overload Protection	electronic throughout full stroke
Operating Range	2...10 V, 4...20 mA w/ ZG-R01 (500 Ω, 1/4 W resistor)
Input Impedance	100 kΩ for 2...10 V (0.1 mA), 500 Ω for 4...20 mA
Position Feedback	2...10 V, Max. 0.5 mA
Stroke	4" [100 mm]
Actuating force motor	100 lbf [450 N]
Direction of motion motor	reversible with switch
Manual override	external push button
Running Time (Motor)	150 s 100 mm
Ambient humidity	max. 95% r.H., non-condensing
Ambient temperature	-22...122°F [-30...50°C]
Storage temperature	-40...176°F [-40...80°C]
Degree of Protection	IP54, NEMA 2, UL Enclosure Type 2
Housing material	UL94-5VA
Agency Listing	cULus acc. to UL60730-1A/-2-14, CAN/CSA E60730-1:02, CE acc. to 2014/30/EU and 2014/35/EU
Noise level, motor	35 dB(A)
Servicing	maintenance-free
Quality Standard	ISO 9001
Weight	2.9 lb [1.2 kg]

†Rated Impulse Voltage 800V, Type of Action 1, Control Pollution Degree 2.

Linear force min. 101 lbf for control of damper surfaces up to 32 sq. ft.

Application

For proportional modulation of dampers in HVAC systems. Actuator sizing should be done in accordance with the damper manufacturer's specifications. The actuator operates in response to a 2 to 10 VDC, or with the addition of a 500 Ω resistor, a 4 to 20 mA control input from an electronic controller or positioner.

A 2 to 10 VDC feedback signal is provided for position indication or master-slave applications.

Operation

The actuator is not provided with and does not require any limit switches, but is electronically protected against overload. The anti-rotation strap supplied with the actuator will prevent lateral movement. The actuator provides 4" [100 mm] of linear stroke. The stroke of the gear rack can be adjusted on both sides in increments of 0.8 in [20 mm] by means of the mechanical end stops. When reaching the damper or actuator end position, the actuator automatically stops. The gears can be manually disengaged with a button on the actuator cover. The actuators use a sensorless brushless DC motor, which is controlled by an Application Specific Integrated Circuit (ASIC). The ASIC monitors and controls the actuator's rotation and provides a digital rotation sensing (DRS) function to prevent damage to the actuator in a stall condition. Power consumption is reduced in holding mode.

Dimensions (Inches[mm])

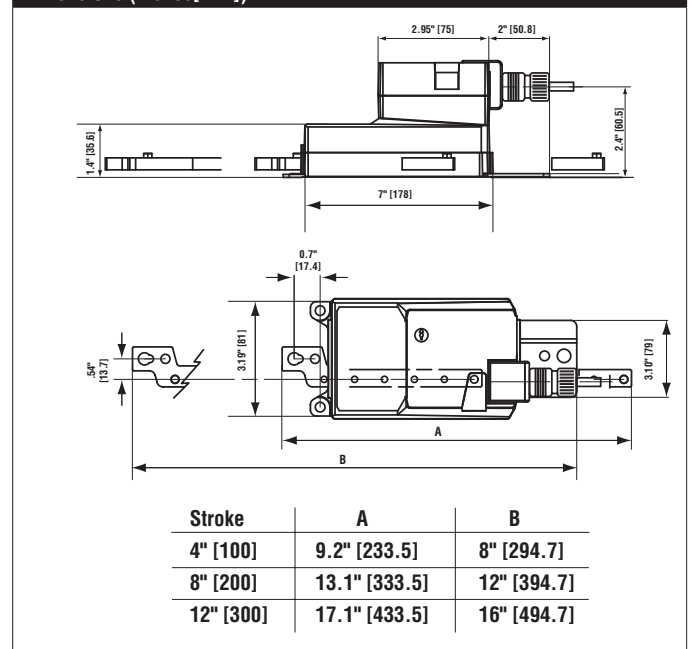

Accessories	
KG10A	Ball joint
KG8	Ball joint
SH8	Push rod for KG6 & KG8 ball joints (36" L, 5/16" diameter).
Z-DS1	Rotary support
Z-KSC	3/8"-16 shaft clevis for AHK/AH.
ZG-119	Bracket for AHK/AH/LH linear actuators.
IRM-100	Input rescaling module for modulating actuators.
PS-100	Low voltage and control signal simulator.
PTA-250	Pulse width modulation interface for modulating actuators.
SGA24	Positioners suitable for use with the modulating damper actuators LM..A-SR, NM..A-SR, SM..A-SR and GM..A-SR
SGF24	Positioners suitable for use with the modulating damper actuators LM..A-SR, NM..A-SR, SM..A-SR and GM..A-SR
TF-CC US	Cable conduit connector, 1/2".
ZG-R01	4 to 20 mA adaptor, 500Ω, 1/4 W resistor w 6" pigtail wires.
ZG-R02	50% voltage divider kit (resistors with wires).
ZG-SGF	Mounting plate for SGF.
ZG-X40	120 to 24 VAC, 40 VA transformer.
NSV24 US	Battery back-up module for non-spring return actuators.
NSV-BAT	12V 1.2AH battery (two required for NSV24 US).

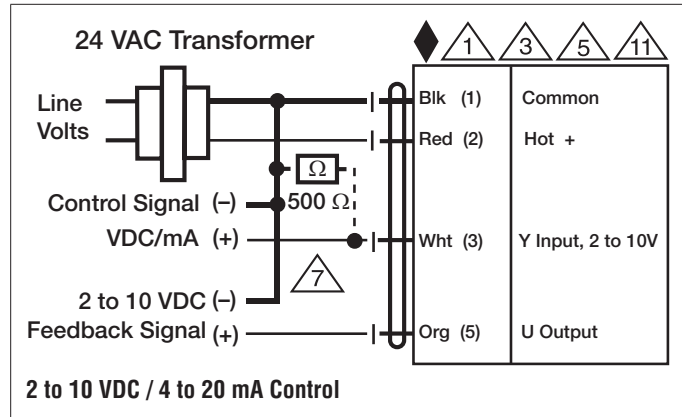

Typical Specification

Proportional control damper actuators shall be electronic direct-coupled type, which require no crank arm and linkage and be capable of direct mounting to a shaft up to 1.05" diameter. Actuators must provide proportional damper control in response to a 2 to 10 VDC or, with the addition of a 500 Ω resistor, a 4 to 20 mA control input from an electronic controller or positioner. Actuators shall have brushless DC motor technology and be protected from overload at all angles of rotation. Actuators shall have reversing switch and manual override on the cover. If required, actuator will be provided with screw terminal strip for electrical connections (AMX24-SR-T and NMX24-SR-T). Run time shall be constant and independent of torque. A 2 to 10 VDC feedback signal shall be provided for position indication. Actuators shall be cULus listed, have a 5-year warranty, and be manufactured under ISO 9001 International Quality Control Standards. Actuators shall be as manufactured by Belimo.

Wiring Diagrams

- 1 Provide overload protection and disconnect as required.
- 3 Actuators may also be powered by 24 VDC.
- 5 Only connect common to negative (-) leg of control circuits.
- 7 A 500 Ω resistor (ZG-R01) converts the 4 to 20 mA control signal to 2 to 10 VDC.
- 11 Actuators may be connected in parallel if not mechanically linked. Power consumption and input impedance must be observed.