

AHB24-3-200 Technical Data Sheet

On/Off, Non-Spring Return, Linear, 24 V



Technical Data	
Power Supply	24 VAC, ±20%, 50/60 Hz, 24 VDC, ±20%
Power consumption in operation	2 W
Power consumption in rest position	0.5 W
Transformer sizing	4.5 VA (class 2 power source)
Electrical Connection	18 GA plenum cable, 3 ft [1 m], with 1/2" conduit connector
Overload Protection	electronic throughout full stroke
Input Impedance	600 Ω
Stroke	8" [200 mm]
Actuating force motor	100 lbf [450 N]
Direction of motion motor	reversible with switch
Manual override	external push button
Running Time (Motor)	150 s 100 mm
Ambient humidity	max. 95% r.H., non-condensing
Ambient temperature	-22...122°F [-30...50°C]
Storage temperature	-40...176°F [-40...80°C]
Degree of Protection	IP54, NEMA 2, UL Enclosure Type 2
Housing material	UL94-5VA
Agency Listing	cULus acc. to UL60730-1A/-2-14, CAN/CSA E60730-1:02, CE acc. to 2014/30/EU and 2014/35/EU
Noise level, motor	35 dB(A)
Servicing	maintenance-free
Quality Standard	ISO 9001
Weight	2.9 lb [1.3 kg]

†Rated Impulse Voltage 800V, Type of Action 1, Control Pollution Degree 2.

Linear force min. 101 lbf for control of damper surfaces up to 32 sq. ft.

Application

For on/off and floating point control of dampers in HVAC systems. Actuator sizing should be done in accordance with the damper manufacturer's specifications.

Operation

The actuator is not provided with and does not require any limit switches, but is electronically protected against overload. The anti-rotation strap supplied with the actuator will prevent lateral movement. The actuator provides 8" [200 mm] of linear stroke. The stroke of the gear rack can be adjusted on both sides in increments of 0.8 in [20 mm] by means of the mechanical end stops. When reaching the damper or actuator end position, the actuator automatically stops. The gears can be manually disengaged with a button on the actuator cover. The actuators use a sensorless brushless DC motor, which is controlled by an Application Specific Integrated Circuit (ASIC). The ASIC monitors and controls the actuator's rotation and provides a digital rotation sensing (DRS) function to prevent damage to the actuator in a stall condition. Power consumption is reduced in holding mode.

Dimensions (Inches[mm])

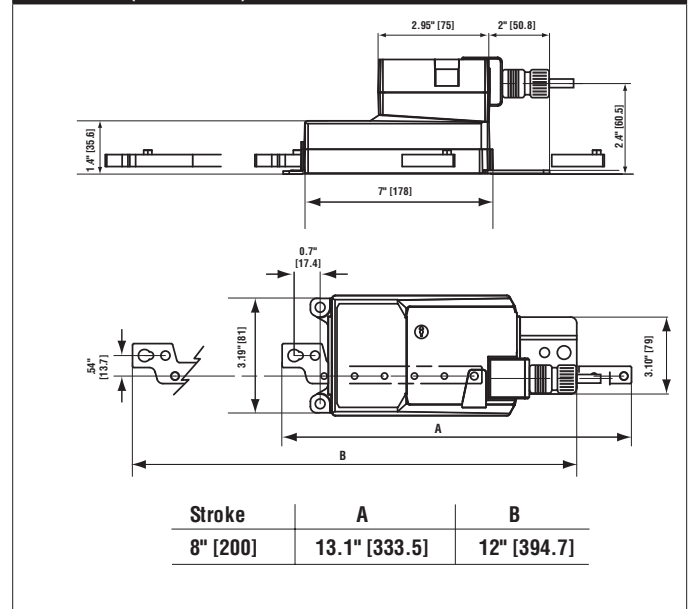

Accessories	
KG10A	Ball joint
KG8	Ball joint
SH8	Push rod for KG6 & KG8 ball joints (36" L, 5/16" diameter).
Z-DS1	Rotary support
Z-KSC	3/8"-16 shaft clevis for AHK/AH.
ZG-119	Bracket for AHK/AH/LH linear actuators.
PS-100	Low voltage and control signal simulator.
NSV24 US	Battery back-up module for non-spring return actuators.
NSV-BAT	12V 1.2AH battery (two required for NSV24 US).
ZG-X40	120 to 24 VAC, 40 VA transformer.
TF-CC US	Cable conduit connector, 1/2".

Typical Specification

Floating point, on/off control damper actuators shall be electronic type, with integrated linear stroking arm. Actuators shall have brushless DC motor technology and be protected from overload at all positions of linear stroke. Actuators shall have reversing switch and manual override on the cover. Run time shall be constant and independent of torque. Actuators shall be cUL listed, have a 5-year warranty, and be manufactured under ISO 9001 International Quality Control Standards. Actuators shall be as manufactured by Belimo.

Wiring Diagrams

- Actuators with appliance cables are numbered.
- Provide overload protection and disconnect as required.
- Actuators may also be powered by 24 VDC.
- Actuators Hot wire must be connected to the control board common. Only connect common to neg. (-) leg of control circuits. Terminal models (-T) have no-feedback.
- Actuators may be connected in parallel if not mechanically linked. Power consumption and input impedance must be observed.

