



Fold here



0% Financing Available

2020 | [casafurnitureusa.com](http://casafurnitureusa.com)  
All rights reserved | 407.567.0020

**casa**  
MODERN FURNITURE

Scan me with  
your camera



MARBELLA  
BED

## DESCRIPTION

Maximize comfort while exuding contemporary appeal with the Marbella Bed. It's sharp angles and sectioned headboard beautifully complement the modern home and the glossy lacquer finish adds to its minimalistic aesthetic.

- Minimalistic contemporary bed.
- High quality lacquer finish.
- Crafted with high quality materials made to last generations.

## MATERIAL

Natural Veneer Wood, Lacquer, Stainless Steel, Acrylic



## DIMENSIONS

Total Weight: 297lb



### BOX DIMENSIONS

KING

Box 1: 85 x 25 x 4 | 102 lb

Box 2: 94 x 30 x 4 | 120 lb

Box 3: 84 x 15 x 5 | 75 lb

### ASSEMBLY

30 MIN

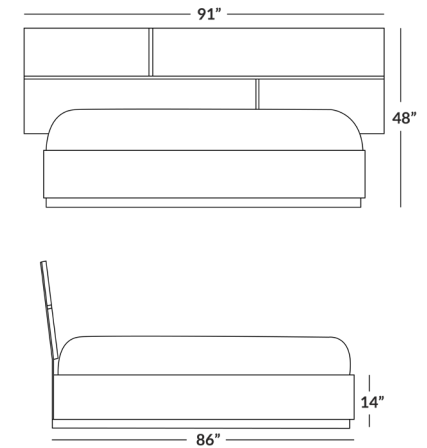

MARBELLA COLLECTION: *Nightstand* | *Dresser* | *Bed*

### AVAILABLE IN:



White Lacquer|Stainless Steel

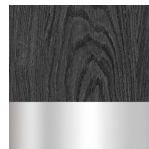

Gray Oak|Stainless Steel

## PRODUCT CARE

### Lacquer

Use a dry, soft cloth to dust lacquer furniture. For heavily soiled furniture, use a mild mixture of soap and water—only do this sparingly. Too much soap or using soap too frequently will ultimately damage the lacquer finish. Important things to remember:

- Always wipe in the direction of the grain.
- Do not use furniture polish as this may damage lacquered furniture.
- Do not use alcohol products, as this may dissolve the lacquer finish.
- Wipe up any spills immediately. Prolonged exposure to colored liquids can stain furniture.

### Stainless Steel

To remove surface stains, use stainless steel cleaner or glass cleaner with no ammonia. Wipe the stainless-steel surface clean with a cloth dampened with the solution then use a clean cloth to dry the surface completely. Important things to remember:

- Always use a soft, dry cloth to finish and dry stainless steel
- Clean stainless-steel at least once every 60 days.
- Keep the bases of chrome polish/finished products away from pets as their bodily fluids may cause damage