

# Surfer Bather

user instructions

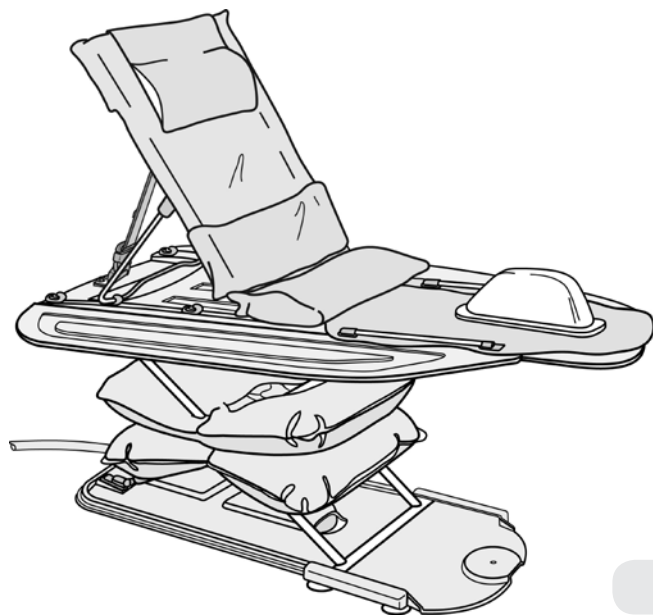

English

*Simple solutions for everyday independence*

## Surfer Bather

Warnings .....	3
Cautions .....	4
Intended use .....	5
Standard product contents .....	5
Fitting/Adjustment of backrest and platform pad .....	6
Fitting the Surfer Bather in the bath .....	7
To raise and lower the Surfer Bather .....	7
To remove the Surfer Bather from the bath.....	8
Routine cleaning .....	8
Disinfecting .....	8
Refitting the netting to the backrest frame after laundering .....	9
Transportation/Storage .....	9
Disposal/Recycling .....	9
List of parts .....	10
To look after your Surfer Bather .....	10
Troubleshooting .....	11
Specifications .....	11
Symbols used .....	12
Warranty .....	12
Declaration of conformity .....	13



**Ensure that you read and understand this instruction manual before using this product. Failure to follow the instructions and safety precautions in this manual can result in damage and/or serious injury.**



**Please keep these instructions in a safe location for future reference**

## **WARNINGS (Risk of possible injury or other serious adverse reactions)**

- The Surfer Bather has been designed to be used in a conventional bath. Some types of corner bath and 'spa' baths which produce multi-jets of water, are not suitable for its use, as the suction cups may not adhere properly. If the Surfer Bather is to be used in a different bath from that in which it is normally used, check for suitability of use and that the suction cups adhere properly.
- Ensure that the locking catches are in the locked position before placing the Surfer Bather in the bath.
- Ensure that any oil and soap residue is removed from the Surfer Bather and bath. Pay particular attention to the suction cups and floor of the bath. Ensure that the suction cups adhere firmly to the bath before each use. The suction cups may not adhere to the surface in baths that have been re-enamelled or that have rippled or textured surfaces. Do not use if the suction cups do not adhere to the bath.
- Ensure that the child's limbs are well within the platform area before raising or lowering the Surfer Bather.
- NEVER leave a child unattended whilst they are on the Surfer Bather.
- The Surfer Bather should only be used as a bathing aid, NEVER use it out of a bath. NEVER use the Surfer Bather to climb in or out of the bath. NEVER use it as a step, stand or as a device for lifting items.
- Do not use the Surfer Bather as a support to steady yourself when cleaning the bath or when reaching into the bath to retrieve items, as doing so may place an uneven or unbalanced load on the Surfer Bather causing it to become unstable.
- The Surfer Bather should only be used for its stated purpose and should not be modified in any way.
- Do not operate the Airflo 12 compressor in the presence of flammable anaesthetic mixtures with air, oxygen or nitrous oxide, as these mixtures can create a combustible environment leading to the potential for fire or even an explosion in the presence of a spark.
- Ensure that when in use, the Airflo 12 compressor, the hand control lead and air hose are laid out in such a way as to avoid any risk of tripping or strangulation.
- Do not allow children to play with the Surfer Bather or Airflo 12 as operation of the equipment in an uncontrolled or unsupervised situation may lead to personal injury and/or damage.
- To avoid personal injury during use and/or damage to the equipment, keep animals away from the Surfer Bather and Airflo 12 compressor.

---

---

## Surfer Bather

---

---

- Before each use, ensure that there are no obvious signs of damage or lose suction cups. If in doubt, do not use and seek advice from your supplier.
- Remove any non slip mats from the area where the suction cups will be positioned.
- To avoid the risk of electric shock, NEVER recharge the battery in the bathroom, outdoors or in a damp environment.
- Do not use any other air supply to inflate the Surfer Bather.

### **CAUTIONS (Risk of possible problems including device malfunctions, device failure, damage to the device or damage to other property)**

- Only recharge the battery with the Mangar Health battery charger supplied with the Airflo 12 compressor.
- Disconnect the Airflo 12 compressor from the Surfer Bather before transporting so as to avoid accidental inflation.
- Do not use bath additives containing peanut oil as this can damage the suction cups. If such additives have been used, ensure that the suction cups are thoroughly wash and rinsed to remove residues.

**For further assistance or information please contact our customer service department by calling +44(0)1544 267674 or email [sales@mangarhealth.com](mailto:sales@mangarhealth.com)**

## Intended use

The Surfer Bather is a pneumatically powered elevating bathing platform designed to assist in the bathing of children. The Surfer Bather is particularly suitable for children with limited upper body stability. The adjustable backrest, together with straps if necessary, provides full support.

Power is provided by the Mangar Health Airflo 12 battery powered compressor.

PLEASE READ the separate Airflo 12 compressor instructions before using your Surfer Bather.

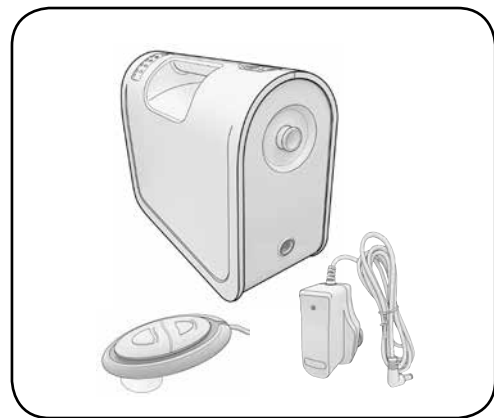

## Standard Contents

- 1 x Surfer Bather platform (A).
- 1 x Scissor lift (including bellows and base board) (B).
- 1 x Backrest (including Headrest pad) (C).
- 1 x Platform Pad with rails (D).
- 2 x Support straps (E).
- 1 x Operating Instructions.
- 1 x Airflo 12 compressor (inc. user instructions).

## Optional Items

- Head Support (not shown).
- Pommel (F).
- Shower Tray Clips (not shown).

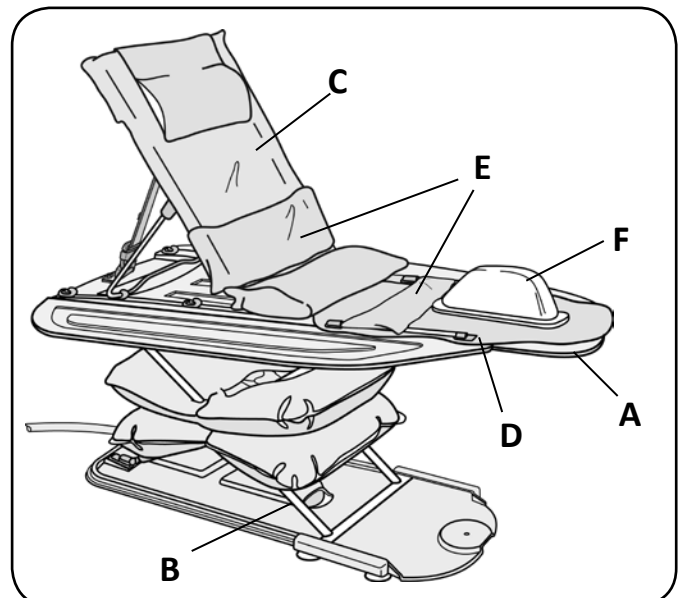

## Fitting/Adjustment of Backrest and Platform Pad

- The backrest and the platform pad are secured to the platform by means of plastic lugs inserted into keyhole slots. Locate and slide the lug into the slot as indicated (**1 & 2** fig. 1), press the locking tag down so that it 'clicks' into place (**3** fig. 1).

**NOTE:** The rear lugs on the platform pad do not have locking tags.

- Fit the backrest hinges to the slots (**A** fig.2).
- Adjust the backrest angle by locating the support bar in any of the three catches (**B** fig. 1). The backrest can be fully lowered by releasing the support bar from the catches and allowing the backrest to lie flat.
- Adjust the backrest angle to the required position and connect the buckle on the backrest restraint strap (**C** fig. 3). Tension the strap in order to lock the backrest angle. If the backrest angle needs to be changed, unfasten the buckle before resetting the angle. Re-connect the buckle and tighten the strap to lock the backrest at its new angle.
- Fit the platform pad (**D** fig. 1) by simultaneously inserting the plastic lugs into the slots (**E & F** fig. 2). **NOTE:** The rear lugs on the platform pad do not have locking tags.

To unfasten the plastic lugs in order to remove the backrest and platform pad:-

- Locate the locking tag from the underside of the platform and press it up (**1** fig. 4).
- Slide and lift the lug clear of the slot (**2 & 3** fig. 4).

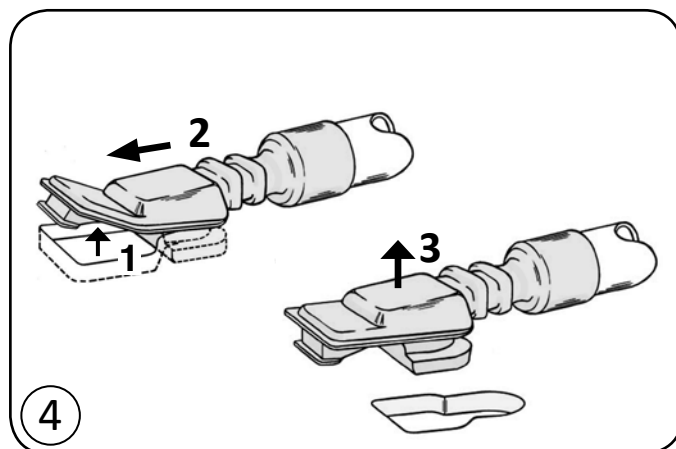
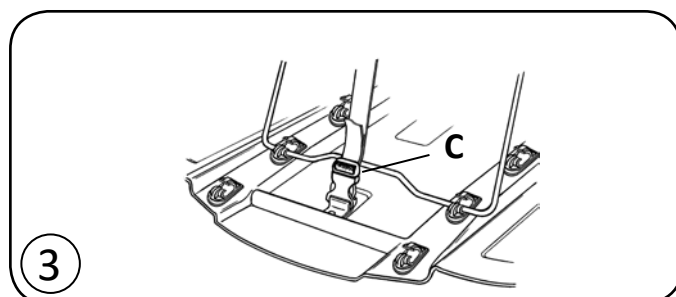
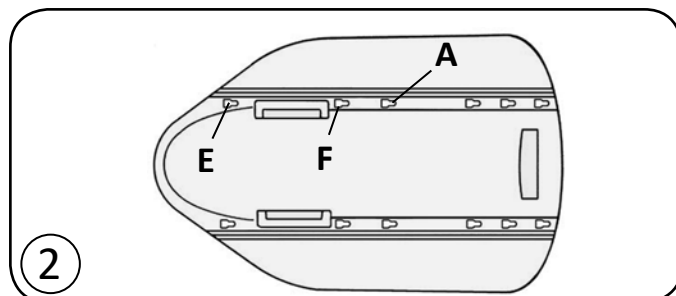
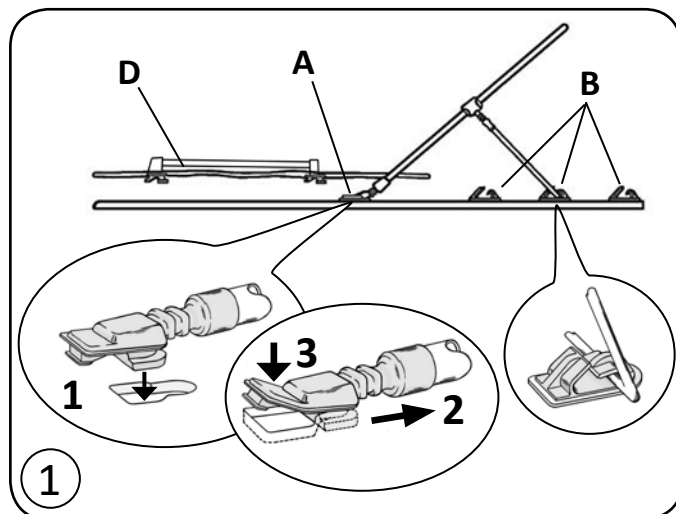

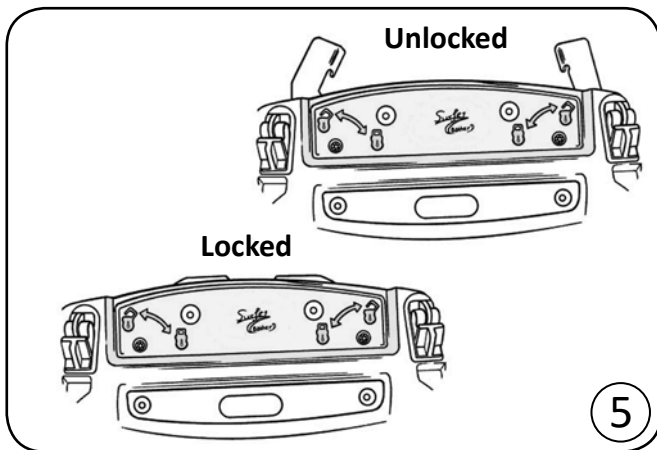

**PLEASE NOTE:** The platform flaps may become stiff following long periods of storage, this can be cured by fully opening and then closing each flap, repeating as necessary until each flap moves easily.

## Fitting the Surfer Bather in the bath

**WARNING:** Ensure that the locking catches are in the locked position before placing the Surfer Bather in the bath (fig. 5).

- Place the deflated Surfer Bather in the bath so that the rear of the platform is as close to the non-tap end of the bath as it will go without resting on the curve of the bath (**A** fig. 6). **Press down on the Surfer Bather to secure the base board suction cups firmly to the bath.**
- Fully inflate the bellows and check that the narrow end of the platform has adequate clearance, between it and any overhanging taps (**B** fig. 6).

**WARNING:** Always ensure that the suction cups are correctly positioned and are adhering to the bath before use.

## To raise and lower the Surfer Bather

**WARNINGS:** Ensure that the child's limbs are well within the platform area before raising or lowering the Surfer Bather.

**NEVER** leave a child unattended whilst they are on the Surfer Bather.

- To raise the Surfer Bather, press 'Up' on the Airflo 12 hand control (fig. 7).
- To stop at any point, release the 'Up' button.
- To lower the Surfer Bather, press 'Down'. **NOTE:** If the Surfer Bather platform rises after reaching the bottom of the bath, press the 'Down' button again and keep it held until the remaining air is expelled from the bellows.

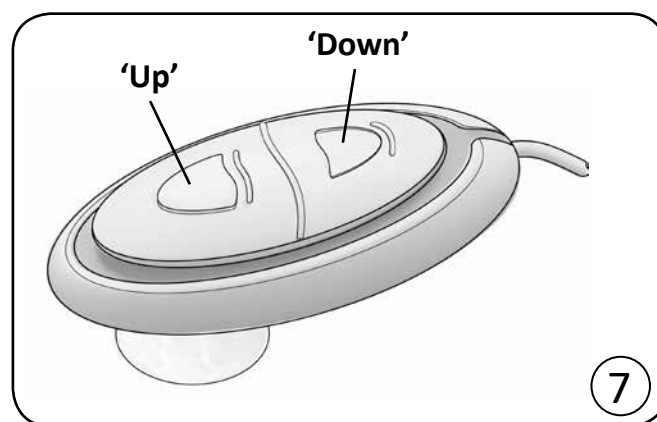
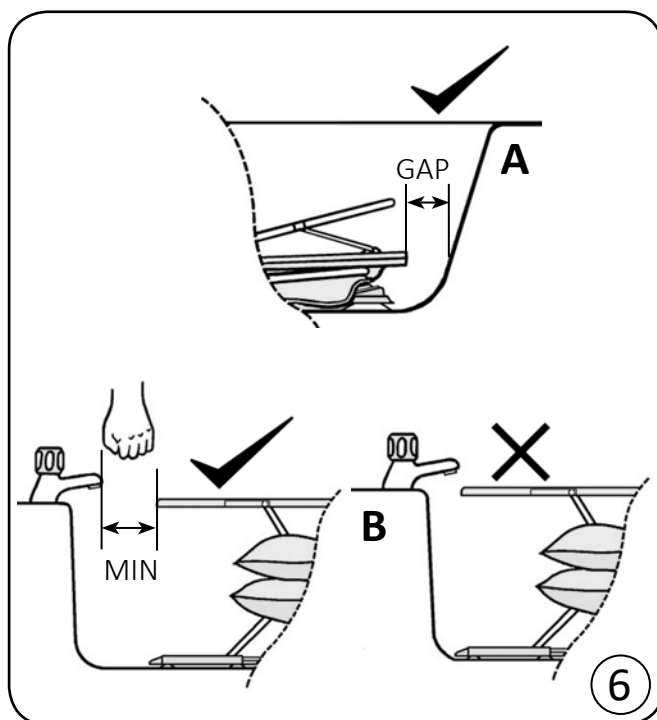

## Surfer Bather

### To remove the Surfer Bather from the bath

- Drain the bath water.
- To aid removal from the bath, the platform should be separated from the scissor lift. Partially elevate the Surfer Bather and pull the locking catch levers fully out (see fig. 5) to unlock the platform from the scissor lift. Unclip the platform from the scissor lift (**1** fig. 8). Swivel the platform as indicated (**2** fig. 8) to disengage the bars from the slots on the underside of the platform.

**NOTE:** The locking catches must be released before attempting to separate the platform from the scissors.

- Lift the rim on each of the two large suction cups on the base board to release the suction between suction cup and bath (**A** fig.9) and remove the scissor assembly from the bath.
- The four small suction cups on the base board (**B** fig.9) will release their suction as the scissor assembly is lifted from the bath.

**NOTE:** Never attempt to remove the Surfer Bather from the bath without first breaking the suction under each of the two large base board suction cups or damage will result.

### Routine Cleaning

After use, fully inflate and rinse with clear water to remove soaps and impurities. The Surfer Bather can be cleaned with a proprietary liquid cleaner or disinfectant; wiped dry or left to air dry- **Do not dry using hot air**. Remove the foam inserts and launder the backrest netting and straps in accordance with the care label instructions. The foam inserts should be hand washed in warm water with detergent and thoroughly rinsed in clean water to remove all soap deposits. Gently squeeze the foam to remove surplus water and leave to air dry.

The Platform Pad should be hand washed only, in warm water using a mild detergent, thoroughly rinsed in clean water and then air dried (The surface of the pad can be wiped to remove excess water- do not wring or put in spin drier)- **Do not dry using hot air**.

### Disinfecting

All components should be pre-cleaned (with the bellows fully inflated) by washing with detergent and water and then disinfected using a proprietary sterilizing solution or any antibacterial cleaner. Rinse after disinfecting- **Do not dry using hot air**.

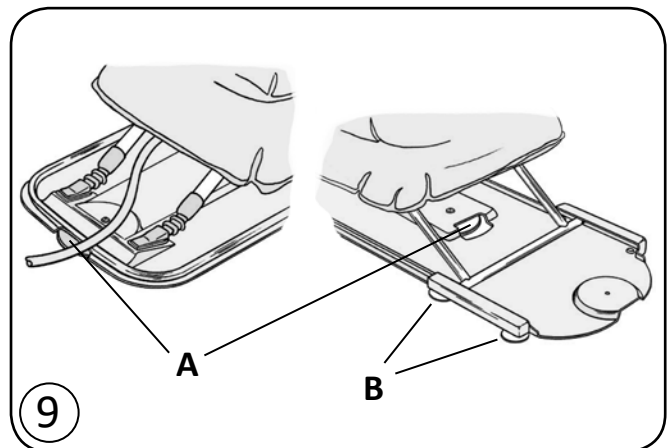
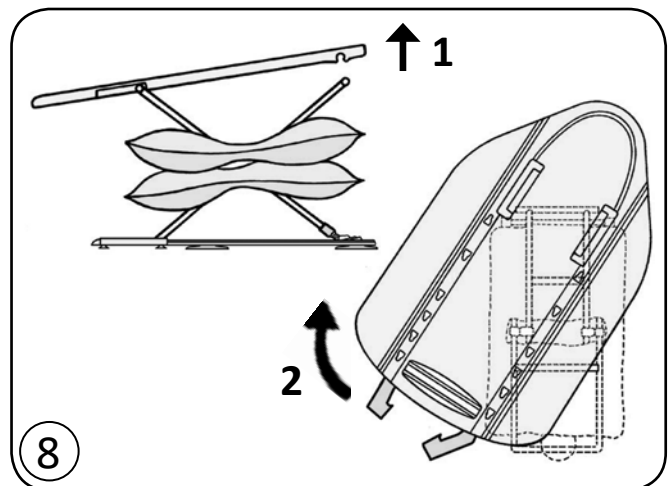



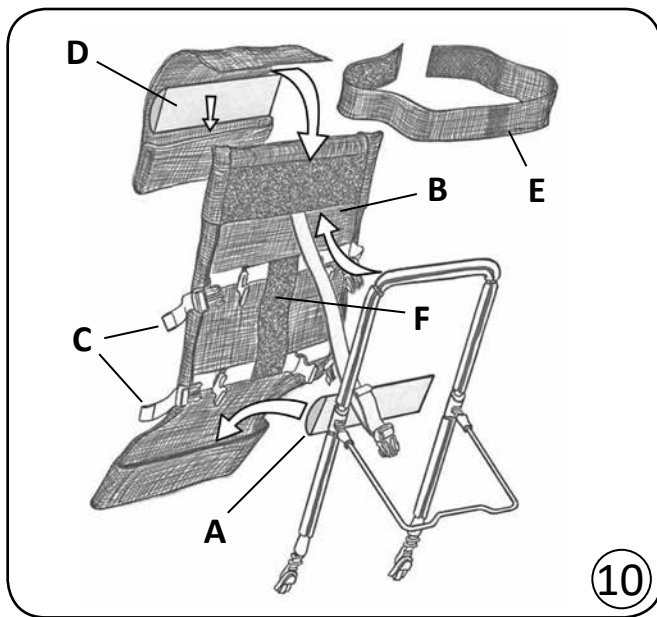

## Refitting the Netting to the Backrest Frame after laundering

- Insert the thigh support foam (**A** fig.10) in the netting lower pocket.
- Insert the backrest frame into the pocket of the netting (**B**) and fasten the four buckles (**C**).
- Tighten or slacken the buckle straps in order to adjust the tension of the netting on the backrest frame.
- Insert the headrest foam (**D**) in the pocket of the headrest netting and if required, Velcro® the headrest to the backrest.
- The chest strap (**E**) can be attached to the Velcro® panel (**F**) as required.

## Transportation / Storage

Disconnect the Airflo 12 compressor from the Surfer Bather before transporting so as to avoid accidental inflation.

Ensure that the Surfer Bather is clean and thoroughly dry before storing. Failure to thoroughly dry the Surfer Bather before storage may result in a build-up of mould on the surface of the product leading to a weakening of the fabric and consequential invalidation of the product warranty. Store in a dry environment.

To maintain the Airflo 12 battery when being stored for long periods, put the Airflo 12 on charge for 16 hours every 3 months.

## Disposal / Recycling

When the Surfer Bather has reached the end of its working life, dispose of it at your local household waste recycling centre (civic amenity site).

When the Airflo 12 has reached the end of its working life, remove the batteries for safe disposal in accordance with your local council guidelines, and dispose of the Airflo 12 at your local household waste recycling centre (civic amenity site).

### List of Parts

1. Platform
2. Platform Catch
3. Scissor assembly
4. Bellows
5. Air hose
6. Bellows Buckle
7. Large suction cups
8. Small suction cups
9. Backrest assembly
10. Backrest Restraint Strap
11. Backrest hinge
12. Backrest Catch
13. Platform Pad
14. Relief valve
15. Base Board

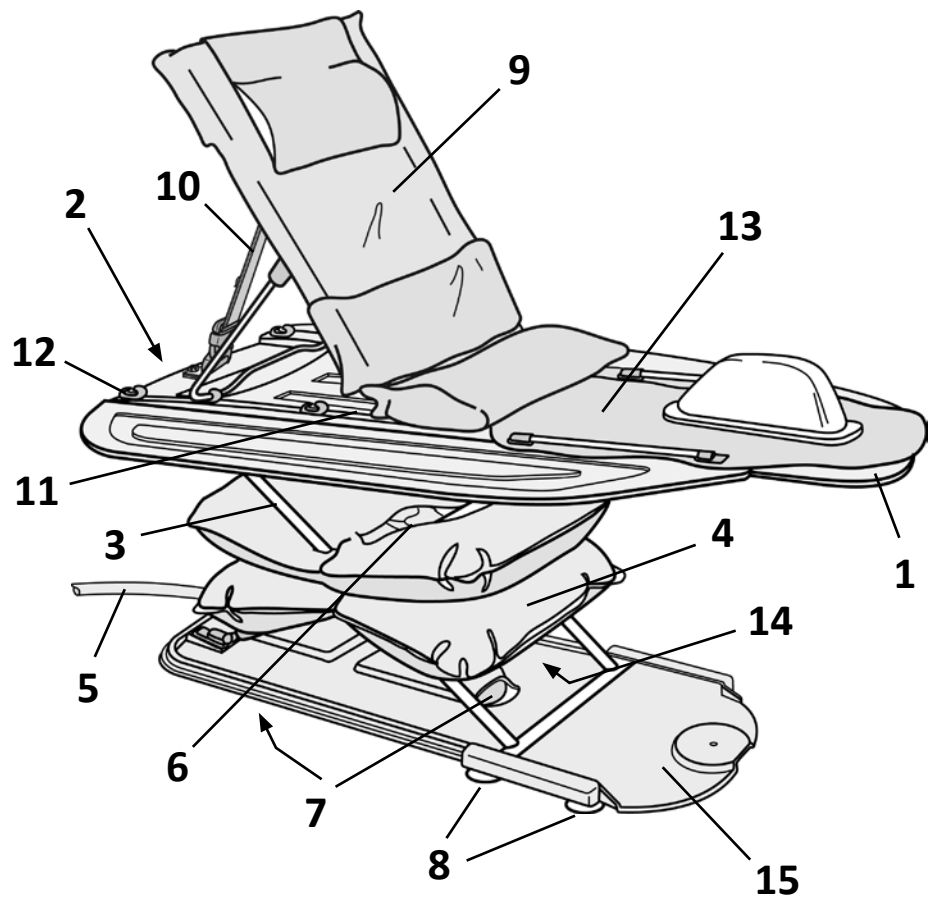

### To look after your Surfer Bather regularly check that:

- The bellows buckle (6) is properly fastened and that the bellows (4) are undamaged.
- The platform catches (2) are secure and undamaged.
- The air hose (5) is undamaged.
- Both large suction cups (7) are undamaged and secure.
- The four small suction cups (8) are undamaged and secure.
- The relief valve (14) is not blocked and vents air when the bellows are fully inflated.
- That the backrest hinges (11) and catches (12) are undamaged and securely located within the slots.
- The Surfer Bather and accessories are kept clean.

Troubleshooting	
Problem	Remedy
<ul style="list-style-type: none"> <li>Surfer Bather fails to inflate or will not stay at the chosen height.</li> </ul>	<ul style="list-style-type: none"> <li>Ensure that the air hose from the Surfer Bather is connected to the Airflo 12.</li> <li>Check that there are no kinks in the air hose and that the air hose is not trapped.</li> <li>Check that the pressure relief valve is operating properly.</li> </ul>
<ul style="list-style-type: none"> <li>Compressor does not run when 'Up' is selected on the hand control.</li> </ul>	<ul style="list-style-type: none"> <li>Ensure that the air hose from the Surfer Bather is connected to the Airflo 12.</li> </ul>
<ul style="list-style-type: none"> <li>Compressor keeps stopping when trying to inflate the Surfer Bather.</li> </ul>	<ul style="list-style-type: none"> <li>Check that there are no kinks in the air hose.</li> </ul>
<ul style="list-style-type: none"> <li>Battery State Indicator light flashing 'Red'.</li> </ul>	<ul style="list-style-type: none"> <li>The compressor's internal temperature cut-out has tripped. Leave the Airflo 12 for 60-90 minutes to cool.</li> </ul>

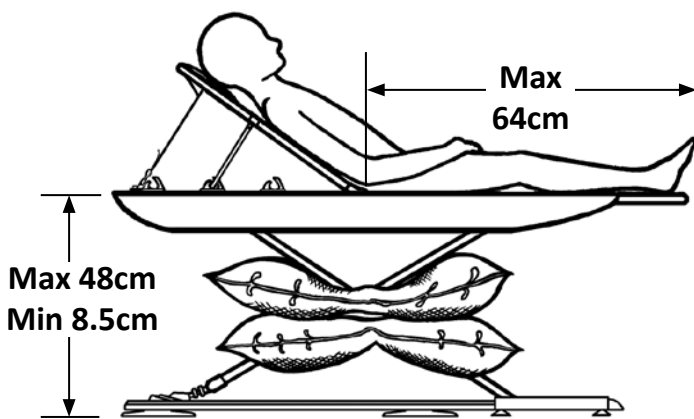

## Specifications

Maximum user weight:	50 kg
Recommended Max. user height:	135 cm
Platform height (min/max):	8.5 cm – 48 cm
Backrest angle:	From flat to 80°
Platform assembly weight:	4.2 kg
Scissor Lift assembly weight:	5.5 kg
Total weight in carrying bag:	9.7 kg
Maximum Air Pressure:	0.35 bar

## Symbols used in the instruction manual and Surfer Bather



Warning - Read the instructions before use



'Up' button



'Down' button



Type BF equipment (protection against electric shock)

## Warranty

The warranty is given against defects in material and workmanship and comprises piece, parts and labour. The warranty is not valid in the case of fair wear and tear, wilful damage, common neglect, misuse or unauthorised alteration or repair by unqualified persons.

The following statements do not affect the consumer's statutory rights. This product is sold on the understanding that in the event of any defect of manufacture or material appearing within the warranty period, the defect will be rectified free of charge providing that:

- (a) Reasonable evidence is provided (e.g. purchase invoice, delivery note) that the claim is being made within the warranty period.
- (b) The defect is not attributable to accidental damage (either in transit or otherwise), misuse or unauthorised repair.

Surfer Bather serial number: .....

Date of purchase: .....

Invoice/Delivery note number: .....

Mangar International, trading as Mangar Health, reserves the right to alter product specifications and/or any of the information contained within this document without notice.

**DECLARATION OF CONFORMITY**

**This is to certify that:-**

The  
Surfer Bather - HSA0141  
and its accessories

**comply with:-**

*The requirements for Class 1 devices according to Annex VII of the Medical  
Devices Directive 93/42/EEC as amended by 2007/47/EC*

**Signed:**



Date: April 2017

C. Butcher (Finance Director)

**Mangar International Ltd**  
Presteigne, Powys, Wales, UK. LD8 2UF  
tel: +44 (0)1544 267674  
fax: +44 (0)1544 260287  
headoffice@mangarhealth.com  
www.mangarhealth.com

**Mangar**  
HEALTH



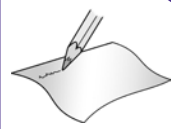

---

---

---

---

*Simple solutions for everyday independence*

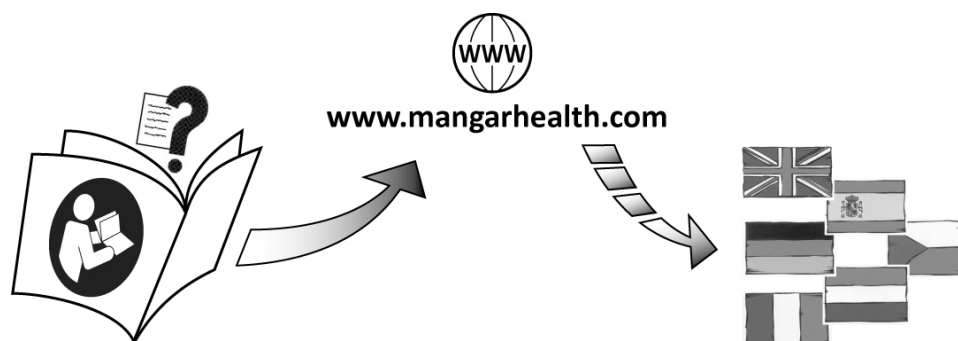

**Mangar**  
HEALTH

**Mangar International**

Presteigne, Powys, Wales, LD8 2UF  
United Kingdom

Tel: +44 (0)1544 267674

Fax: +44 (0)1544 260287

E-mail: [sales@mangarhealth.com](mailto:sales@mangarhealth.com)

[www.mangarhealth.com](http://www.mangarhealth.com)

MI0434 Issue 1  
(08/17)