



AIR SWAG USER MANUAL

Please read this manual carefully before installation, and retain it for future reference.

V1.2

ABOUT US

Founded in 2018, the San Hima brand stands for passion and enthusiasm for exploring the spectacular nature of the great outdoors. Since its inception, the trusted solutions and proven designs that San Hima offers to the market have made adventure and travelling flexible and enjoyable!

Based in Australia, San Hima has under its umbrella a wide selection of outdoor solutions, including cargo systems, vehicle protection accessories and tow & trailer parts, that are designed to help you carry your gear wherever your passion takes you and boost your performance when conquering the peaks!

At San Hima, we have wild souls and we are committed to designing products that are tough enough to take on any adventures and at the same time, making them safe and easy to use. These values in our conviction are what drive us to make innovations. Since pursuit your passion shouldn't be complicated.

Live the Peak, Conquer the Everest, San Hima is your brand of choice!

TABLE OF CONTENTS

1. IMPORTANT INFORMATION	1
2. WARNINGS AND SAFETY INSTRUCTIONS	2
3. PARTS LIST	4
4. LAYOUT	5
4. SETUP INSTRUCTIONS & STEPS	6
5. MAINTENANCE AND STORAGE	9
6. WARRANTY	10



IMPORTANT INFORMATION

- San Hima is not liable for damage or accidents resulting from non-observance of the instructions, changes to parts, or the use of parts other than San Hima's original parts.
- The warnings, safety and setup instructions in this manual cannot cover every imaginable situation, so it is the user's responsibility to exercise common sense and caution.
- It is your responsibility to pass these instructions on to third parties using this air swag, including second-hand sales.

WARNINGS AND SAFETY INSTRUCTIONS

GENERAL GUIDELINE:

- Before pitching the San Hima air swag, please choose a suitable site. The user manual of this swag should ALWAYS be kept at hand.
- Regular inspection of the swag for damage and wear increases the level of safety, broken or defective parts must be replaced.
- DO NOT use your swag if there is ANY visible damage to ANY part of the swag, instead contact San Hima to see how we can help.
- NEVER force ANY of the components which could result in damage when opening and closing the swag.
- ANY dirt or stains can be removed by brushing, or gently washing, using cold water. DO NOT use cleaning fluids containing bleach, alcohol or ammonia or ANY other chemicals that would otherwise damage your swag.
- ALWAYS ensure the swag is dry prior to closing and storage. If this isn't possible, open immediately when you arrive at your home or next destination. Storing a wet swag can lead to the formation of mold & mildew.
- Recommended to store your swag indoors if it's not going to be used for a long time.
- NEVER leave the swag open for a long time where insects, rodents, or moisture could occur.
- DO NOT leave your swag unattended.

FIRE HAZARDS:

- DO NOT set up cooking or heating devices inside the swag.
- Keep the swag away from open fire.
- Keep a look out for ANY airborne burning embers that may come into contact with the swag.
- Keep a fire extinguisher or water bucket nearby.
- DO NOT smoke within the swag.
- Ensure there is ALWAYS an unobstructed path of escape out of the product. Keep calm in the event of fire and leave the swag on the shortest way.

VENTILATION:

- If the inside of the air swag is not adequately ventilated, there is a risk of suffocation. Make sure the windows are ALWAYS open in the event of high temperatures.
- DO NOT leave children unattended in the swag.
- Avoid continual exposure to sunlight to prevent the accumulation of heat inside the swag.

SITE SELECTION & SETUP:

- Ensure that you site the air swag on clear/level ground before set up, with no sharp objects beneath and zips fully closed.
- San Hima recommends conducting a trial run of your swag to familiarise yourself with the assembly. Should you have ANY issues in relation to setting up your swag; please contact San Hima for assistance before your holiday.
- Incorrect setup, improper handling of the swag could result in damage.
- DO NOT place the swag with its entrance against the wind.
- DO NOT place ANY objects on top of the swag.
- If a zip opening is tight it is more than likely due to the fact that your swag or its awning is not pitched correctly.

- Once set up, the pole is under tension. Please note that improper handling of the pole may result in injury.
- Ensure the poles will not end up in the hands of children.
- Keep the guy ropes out of the reach of children. DO NOT allow children to play with the guy ropes. If they end up in the hands of children, they could strangle themselves.
- NEVER use electric air compressors.

EXTREME WEATHER CONDITIONS:

- Your swag is not created for extreme weather conditions. DO NOT use, set up or leave your air swag in ANY potentially harsh weather conditions such as: harsh rain, hail, sleet, snow, extreme cold or heat, lightning etc.
- Promptly take the swag down in the event of an incoming storm, thunderstorm or in case of strong wind. Even if properly anchored, it may come loose.
- DO NOT expose your swag to snow loads. It cannot withstand them. This swag is not suitable for use in temperatures below -10°C(40°F) or when there is a snowfall. Disassemble the swag in case of snowfall.

CLEANING:

- DO NOT use any aggressive cleaners, sharp or metallic cleaning utensils such as knives, hard scrapers and the like. They could damage the surfaces.
- NEVER wash the product in the washing machine.
- NEVER have the product dry cleaned.
- ONLY use clean water to clean the product.
- Let the inner and outer swag dry completely before storage.

AIR MATTRESS:











- Do not over inflate the air mattress.
- When the air mattress is not in use, fold it and store it in a location inaccessible to children.
- Do not walk, stand on or jump on or use the mattress as a trampoline.
- Do not use the mattress on or near bodies of water, as it is not intended for use as a flotation device.
- Ensure that the surface on which the mattress is placed is flat, smooth, even, and free from any sharp objects that could potentially puncture the mattress.
- Limit the operation of the electric air pump to a maximum of 15 minutes at a time and allow the pump to cool for at least 5 minutes between uses.
- Disconnect the electrical power cord when the air pump is not in use.
- In the event of any necessary repairs, use the provided repair kit only.
- Avoid using the product in situations where there is a risk of the pump coming into contact with water or other liquids. If the pump has been in contact with water or liquid, refrain from handling it. Disconnect the plug from the electrical socket immediately and contact San Hima.
- Never use the product if the pump's power cord or plug is damaged, if the pump casing is compromised, or if it is not functioning correctly. Contact San Hima for assistance.

PARTS LIST

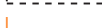

SH-AIR-SWAG-001A	SH-AIR-SWAG-002A
1 PC(s) San Hima Air Swag (1P)	1 PC(s) San Hima Air Swag (2P)
2 SET(s) Poles	2 SET(s) Poles
8 PC(s) Pegs	8 PC(s) Pegs
4 PC(s) Guy Ropes	4 PC(s) Guy Ropes
1 PC(s) Hurricane Pump	1 PC(s) Hurricane Pump
2 PC(s) Storage Bags	2 PC(s) Storage Bags
2 PC(s) Carry Bags	2 PC(s) Carry Bags
1 PC(s) Air Mattress (Includes a Repair Kit and a Valve Cap)	1 PC(s) Air Mattress (Includes a Repair Kit and a Valve Cap)
1 PC(s) Electric Air Pump with CIG Socket	1 PC(s) Electric Air Pump with CIG Socket

LAYOUT

-  Bedroom
-  Awning Area
-  Storage Pockets
-  Window
-  Door
-  Mesh
-  Shoe Changing Area
-  Inner Dimension
-  Air Valve
-  Air Pole

SH-AIR-SWAG-001A

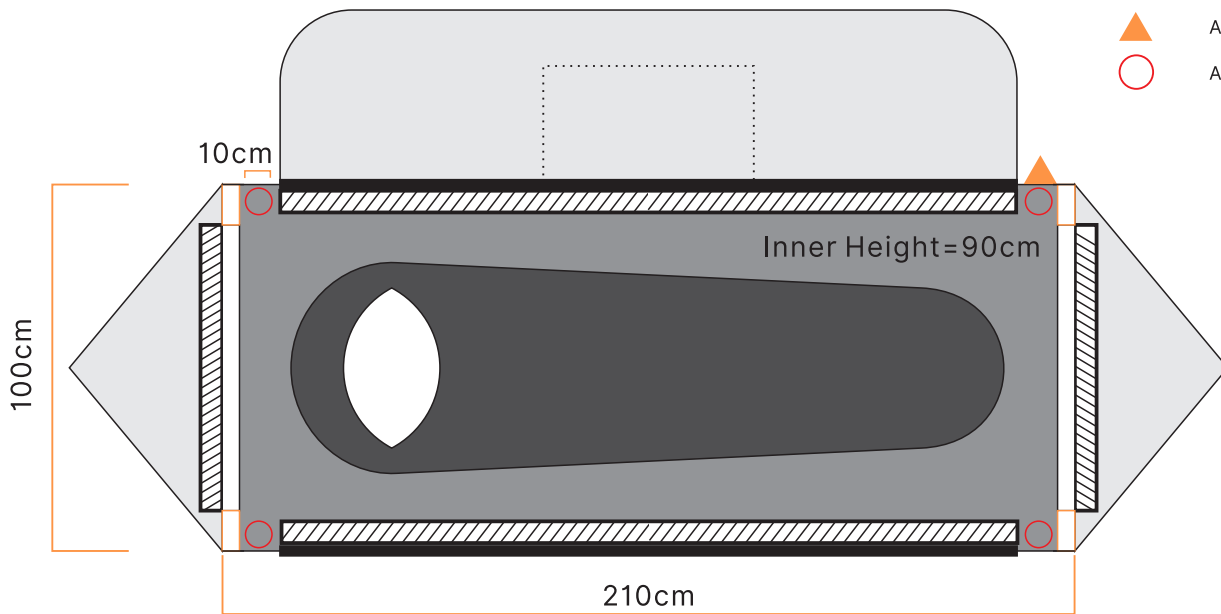

SH-AIR-SWAG-002A

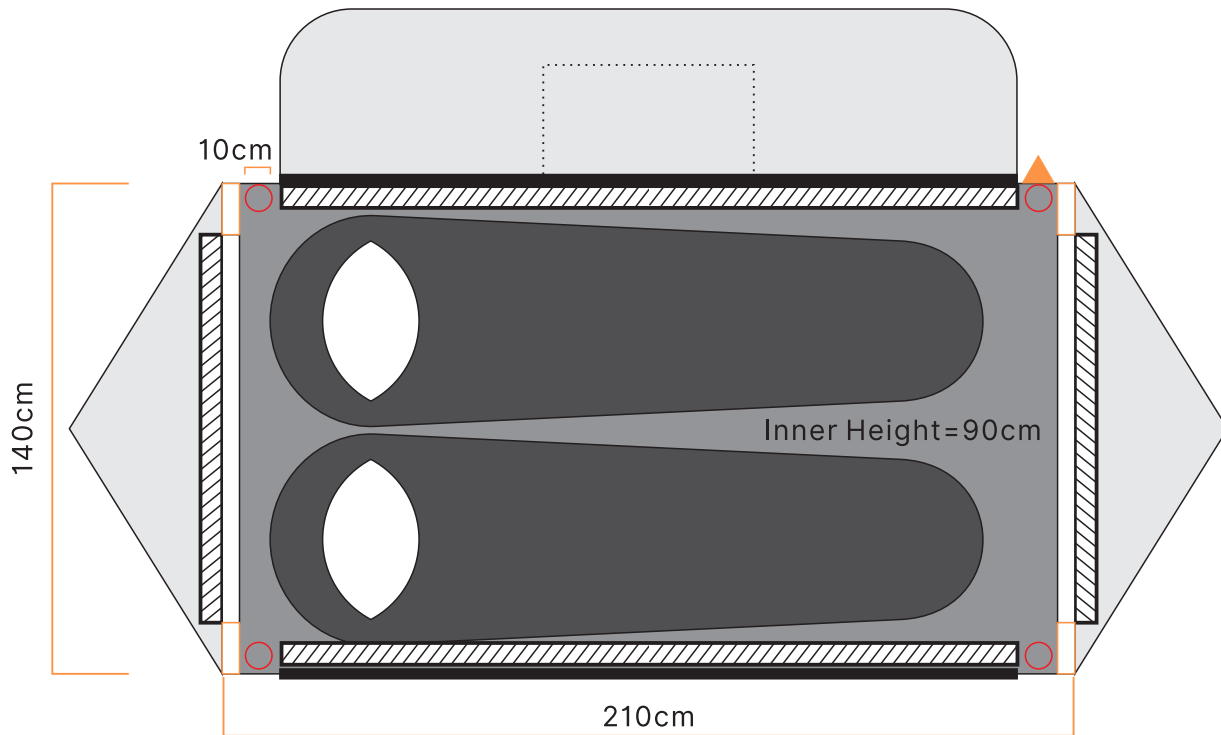

SETUP INSTRUCTIONS & STEPS

1. TEST RUN (RECOMMENDED)

It is recommended to practice setting up your San Hima air swag in a suitable site to ensure you've fully understood the steps.

2. SITING

Select a site that is dry and level and, if possible, protected from the wind. Clear the ground of any sharp objects to avoid damaging the swag. It is recommended to set up your swag with the door facing away from the wind. DO NOT pitching your swag under the trees as falling branches and sap might damage the swag.

3. UNPACKING

Be careful when opening.

- (1) Take the product out of the package.
- (2) Check to make sure that the product and its accessories is complete (see parts list).
- (3) Check whether the product or the individual parts exhibit damage. If there is ANY, DO NOT use the product.

San Hima recommends taking a photo to see how the product is packed. This will help you when it comes to storage.

4. UNFOLDING

Spread out the swag, ensure the floor facing down, orient the tent in the correct direction and peg out the four main corners ensuring the swag is pulled taut and square. It is recommended to pitch the swag so it is in line with wind, never side on.

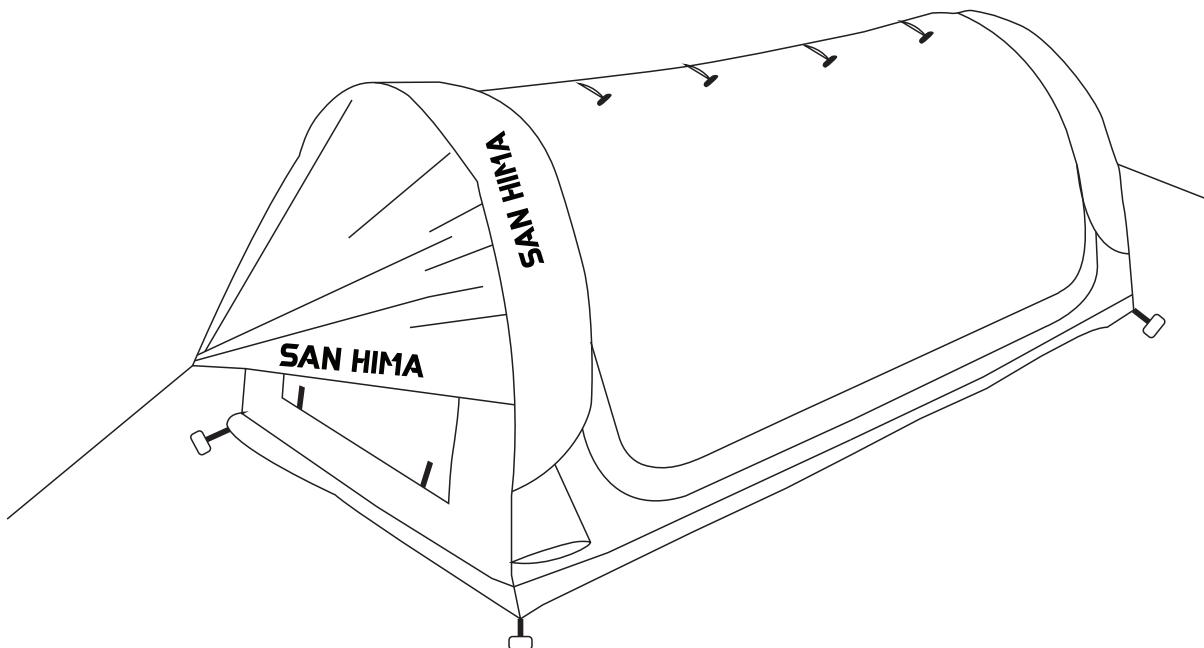

5. INFLATION AND DEFLATION

Air Swag:

There is an external valve located on the air tube. Before inflating, unscrew the valve cap on top of the valve. Insert the pump hose into the valve and start inflating with the supplied San Hima Hurricane air pump. You may need to help the tube stand up when the tube feels rigid. Once you have finished inflating, remove the pump nozzle and tighten the outer securing cap.



Air Mattress

Inflation:

1. Attach the air valve to the air mattress.
2. Unscrew the cap from the air valve, then connect the air pump to it.
3. Once inflation is complete, disconnect the pump and secure the cap.



Deflation:

1. Remove the air valve.
2. Connect it to the electric air pump.
3. When finished, remove the pump.



6. ADJUST THE FLOOR

Making sure the swag is sitting evenly. You may need to adjust the base of each air pole so it sits flat with the ground.

7. PEGGING

When pegging, make sure the pegs are at a 45° angle.

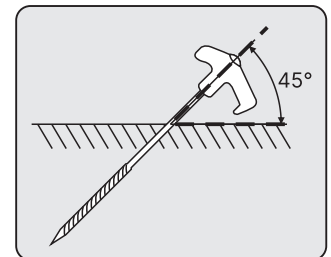

8. GUY ROPES

Unravel the guy ropes and pull them away from the swag, while making sure they are tensioned. Secure the guy ropes at suitable spots in the ground using the pegs. Use a hammer (not included) if necessary to drive the pegs into the ground.

9. AWNING

Starting from one side of the awning, slide the top of the pole through the ring of the awning. Secure the pole in place by its end into the ground. The pole has been set up and is under tension.

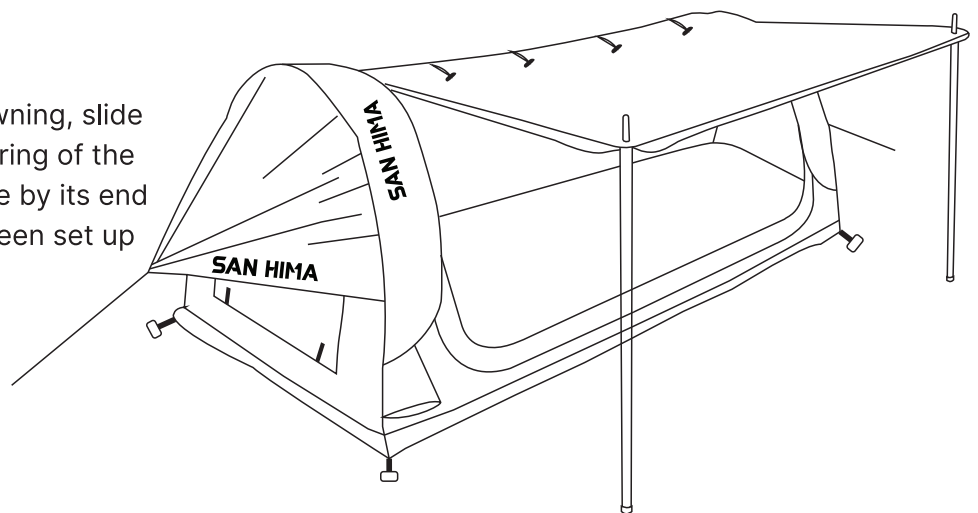

10. DEFLATION

- (1) Close the mesh door, but leave the cover open to allow air to escape.
- (2) Peg out all ropes and roll them up.
- (3) Peg out all pegs. Clean and dry the pegs before storage.
- (4) Carefully open the outer cap of the valve. Carefully press the beam to release the air. Never force the air out of the beam, as you might risk damaging the beam. When packing the swag away, the valves should be left open to allow any trapped air to escape.

11. FOLDING

Ensure that the air valve is not obstructed to allow the remaining air to escape. To reduce the chance of valve malfunction, the valve should be fully unscrewed when the product is in storage. Ensure the swag is completely dry and clean before storing away and store it in a dry environment. Follow the steps below to pack your air swag.

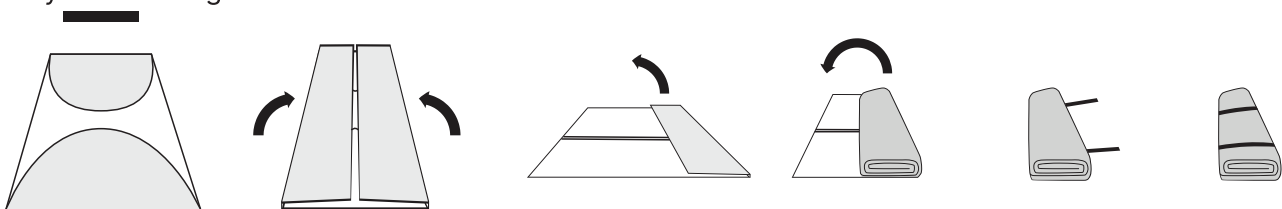

IMPORTANT:

- Your San Hima air swag is made from the best available materials. After several times of use, you may find some slight variances in colour and changes due to the weather and environment. These are all normal and will not affect the performance of the product and are not faults or errors.
- You may also experience, depending on the weather and use, condensation. This should not be confused with leakage. To reduce the risks of condensation, please ensure your swag is adequately ventilated. Please note that under certain conditions, all swags will suffer from internal condensation depending on atmospheric conditions, the weather, the amount of moisture in the air/ ground, evening and night time temperatures etc.
- Discolouration of the fabric may be an early indication that your swag has been attacked. To limit damage by UV, wherever possible, please site your swag in a shaded area avoiding direct sunlight. Fabrics can be weakened by prolonged exposure to sunlight.

MAINTENANCE AND STORAGE

The San Hima air swag is designed to be a reliable companion on your adventures. In order to keep it performing at its best, San Hima recommends some care and maintenance steps that will help prolong its life.

- Prior to each use, inspect your air swag and its accessories.
- Dry your swag thoroughly before you close it. If unable to properly dry your air swag prior to closing, open it up and air dry it at your next opportunity. Failure to properly dry your swag can lead to the growth of mold and mildew which can degrade the swag material, cause discoloration, and foul odor.
- To clean your swag use with cold water and a sponge. DO NOT use soap or detergent. Rinse with a clean wet sponge and allow to thoroughly dry.
- Zippers should be pulled with even force and in a gentle manner. Keep your zippers free from dust and dirt.

WARRANTY

San Hima (“Manufacturer”) warrants, to the original purchaser (“User”) that its swag, if purchased from manufacturer or an authorized distributor or dealer, will be free of defects in material and /or workmanship under normal usage from the date sold and for the duration (the “Warranty Period”) of 2 YEARS.

This warranty shall ONLY be effective for the original purchaser and apply ONLY to the San Hima air swag that is correctly installed on the vehicle for which it is intended.

San Hima will either replace the product or provide you with a refund at our discretion provided that the fault is found to have been caused by a design or manufacturing defect that results in its failure to perform correctly as described. The limited warranty is the only one that applies to this product, and it sets forth all the responsibilities of San Hima.

EXCLUSIONS:

This warranty does not cover defects, failure or damage caused by incorrect installation, inswagional damage, misuse or abuse. It is recommended that the installation should be performed by suitably qualified technicians or the warranty will be voided. For further clarity, this warranty is also void if the air swag:

- is repaired, altered or modified carried out by anyone other than San Hima, or without San Hima's authorization,
- is damaged by mold and mildew as the swag is not properly dried prior to closing,
- is damaged by extreme weather (e.g. storm, hail or strong wind), extreme temperature, accidents, negligence, daily wear and tear, incorrect setup, or failure to check the condition of swag before each use,
- is damaged by UV degradation or acid rain to the swag/awning and its components,
- is damaged from improper storage, or a failure to provide routine maintenance,
- is used on permanent sites or commercial displays.

CLAIMS:

If a San Hima product is suspected of being defective, you'll need to provide proof of purchase (e.g. a screenshot of the order) and a picture and a video of the damaged goods in their entirety to sales@sanhima.com. If the product is found to be defective and covered by this limited warranty, the remedy is replacement or refund, at San Hima's option. No charges will be accepted for external labour or materials.