



## **ELECTRIC WINCH USER MANUAL**



BI-WINCH13000-ROPE

To ensure an effective installation, it is essential to thoroughly read  
and understand this manual beforehand.

V1.1

BUNKER INDUST, a disruptive force that aims to help people pursue their passions in the great outdoors with rugged looks and impeccable safety, is a professional provider of a full lineup of 4x4 upgrades and accessories that enable off-road enthusiasts to upgrade their vehicles and pursue an outdoor lifestyle.

At BUNKER INDUST, we regularly spend time outdoors to understand your desire to have an ideal rig. But that move is challenging and time-consuming. But it's what sets us apart. Because we are driven by enthusiasm, not commission, and share the same passion for vehicle upgrade as you do.

When you decide to build a vehicle to hit the trails, BUNKER INDUST is here to prepare it with virtually all the off-road parts required to keep you safe, and make sure your vehicle looks and performs as you want it to.

BUNKER INDUST, Build Your Own Legend.

For your safety, please thoroughly review all instructions and warnings before operating the equipment. Failure to follow proper procedures may result in fire, injury, severe damage, or even loss of life. Please note that this manual does not cover all possible winching situations. It is highly recommended to utilize the winch responsibly and in accordance with safety guidelines.

## **GENERAL SAFETY:**

- Prior to each use, thoroughly inspect the electric winch for any signs of damage or loose parts. If any damage or looseness is detected, do not use the winch.
- When not in use, store the electric winch in a dry and secure location that is inaccessible to children. Before storage and subsequent re-use, conduct a thorough inspection to ensure it is in good working condition. Regularly inspect, clean, and maintain your synthetic winch rope to extend its lifespan.
- To prevent accidental activation, avoid placing your remote control in your pocket while winching.
- Do not exceed the rated load capacity. Be aware of dynamic loading. Sudden load movement may briefly create excess load causing product failure.
- This winch is exclusively designed for horizontal pulling and must not be used for lifting loads under any circumstances.
- Move the protective sleeve to cover parts of the rope that may come into contact with rough surfaces or sharp edges.
- Keep in mind that a minimum of 8 layers of synthetic rope should remain on the drum.
- Do not operate this winch while under the influence of drugs, alcohol, or medication.
- Avoid using inappropriate attachments to extend the length of the winch cable.
- Do not use the winch or winch rope for towing purposes.
- Never use the winch to secure a load.
- Note that the control box and remote controllers are not waterproof.
- When operating the winch, it is imperative to keep children and bystanders at a safe distance from the work area.

## **PERSONAL SAFETY:**

- It is crucial to avoid distractions and stay fully attentive while operating the winch, as a momentary lapse in concentration can lead to severe personal injury.
- Keep your hair, clothing, and gloves clear of any moving components. Loose attire, jewelry, or long hair may become caught in the moving parts, causing harm.
- Exercise caution around air vents on the tool, as they often conceal moving parts and should be avoided to prevent accidents.
- Refrain from using the electric winch if you are fatigued.

## **INSTALLATION SAFETY:**

- Ensure that the mounting location is sufficiently sturdy to withstand the maximum pulling capacity of your winch.
- Complete the winch installation and hook attachment before proceeding with the wiring installation.
- Avoid routing electrical cables across sharp edges, through or near moving parts, or in close proximity to components that generate heat.
- Keep hands clear of winch rope, hook loop, hook and fairlead opening during installation, operation, and when spooling in or out.
- Avoid welding the mounting bolts under any circumstances.

## WINCHING SAFETY:

- Before operating the winch, inspect the winch rope, hook, and other components. Promptly replace any winch rope that is frayed, kinked, or damaged. Additionally, damaged components should be replaced prior to operation.
- The winch motor may become hot during use. If you winch for more than 1 minute, or if the winch stalls during operation, stop winching and allow the winch to cool down for at least 10 minutes before using it again.
- Maintain a clear distance from the wire rope, hook, and load while winching. Refrain from stepping over the wire rope and avoid pushing sideways against the wire rope under tension, as it may break and recoil, causing injury to individuals nearby.
- Only engage the winch while the transmission of the winching vehicle is in neutral. Operating the winch with the transmission in gear or park may result in transmission damage, as it is not designed for such loads.
- Avoid operating the winch on extreme slopes and ensure that the angles for a roller fairlead are not exceeded. For a hawse fairlead, aim for an angle as close to 180 degree as possible.
- In the event of an electric pulling winch malfunction, immediately cease operation without attempting any further actions. Establish a safety perimeter around the winch and the load to prevent unauthorized access.
- Individuals with pacemakers should consult their physicians before using the winch. Electromagnetic fields in close proximity to a pacemaker can interfere with or cause the pacemaker to fail.
- Never place a load on the tip or latch of the hook. Apply the load only to the center of the hook.
- Always ensure the clutch is fully engaged or disengaged to maintain winching capacity.
- When releasing the winch line, always use free spooling instead of powering it out.
- During winch pulls, keep your engine running and monitor the voltage gauge of your vehicle.
- Operate the winch at an angle not exceeding 15 degree to prevent damage to winch components.
- Observe your winch while operating from a safe distance.
- Never exceed the pulling limits of this winch.

## WHAT'S INCLUDED

1 PC(s) BUNKER INDUST Electric Winch  
1 PC(s) Control Box  
1 PC(s) Hawse  
1 PC(s) Hook  
1 PC(s) Hook Strap  
1 PC(s) Remote Controller  
1 PC(s) Wired Controller  
1 PC(s) Cable

6 PC(s) M10 Screws  
6 PC(s) M10 Spring Washers  
6 PC(s) M10 Washers  
6 PC(s) M10 Nuts  
2 PC(s) M5 Screws  
2 PC(s) M5 Spring Washers  
2 PC(s) M5 Washers  
1 PC(s) User Manual



# SPECIFICATIONS

Model No.:	<b>BI-WINCH13000-ROPE</b>
Product Dimension:	55.2 x 17.8 x 27.0cm (21.73 x 7.01 x 10.63")
Net Weight:	28.2kg (62.17lbs)
Housing:	Aluminum
Finish:	Matte Black Powder Coating
Hawse:	Aluminum
Hook:	Forged Steel
Waterproof:	IP-67
Rated Line Pull(Single Line):	5,897kg (13,000lbs)
Motor:	DC 12V, 6.6HP/4.8KW, High Performance Series Wound
Gear Train:	3-Stage Planetary
Gear Reduction Ratio:	195.8:1
Free Spooling Clutch:	Sliding Ring Gear
Drum Diameter/Length:	Φ 6.4x 22.4cm (2.52 x 8.82")
Brake:	Automatic in-the-Drum
Duty Cycle:	Intermittent Per SAE J706 Section 6.2
Mounting Bolt Pattern:	25.4 x 11.4cm (10 x 4.5")
Recommended Battery:	650CCA
Control Mode:	Wired/Wireless Control
Full Load Line Speed:	2.3m/min (7.6 ft/min)
No-Load Line Speed:	7.0m/min (23ft/min)
Max Current at Full Load (A):	420
Max Output Power of DT Socket (W)	60
Certification:	CE

<b>Synthetic Rope:</b>	
Material:	UHMWPE
Length of Synthetic Rope:	26.0m (85.30ft)
Breaking Capacity:	6,648kg (14,656lbs)
<b>Remote Controller:</b>	
Operating Band:	433MHz
Remote Control Distance:	18.0m (59.1ft)
Input Voltage:	5V
Waterproof:	No
<b>Warranty:</b>	
Electric Components:	2 Years
Mechanical Components:	3 Years
Synthetic Rope:	1 Year

## 13,000LBS LINE PULL AND CABLE CAPACITY

Layer of cable		1	2	3	4
Rated line pull per layer	lbs	13,000	9,210	8,030	6,894
	kg	5,897	4,178	3,642	3,127
Cumulative Cable Capacity	ft	15	39.3	68.9	85.3
	m	4.58	12	21	26

## 13,000LBS LINE SPEED AND AMP DRAW (FIRST LAYER) 12V

Line Pull	lbs	0	4,000	6,000	8,000	10,000	13,000
	kg	0	1,814	2,722	3,629	4,536	5,897
Line Speed	ft/min	23	16.8	12.8	10.1	8.8	7.6
	m/min	7	5.1	3.9	3.1	2.7	2.3
Motor Current	amps	70	158	231	270	370	420



# PREPARATION

## Know Your Electric Winch

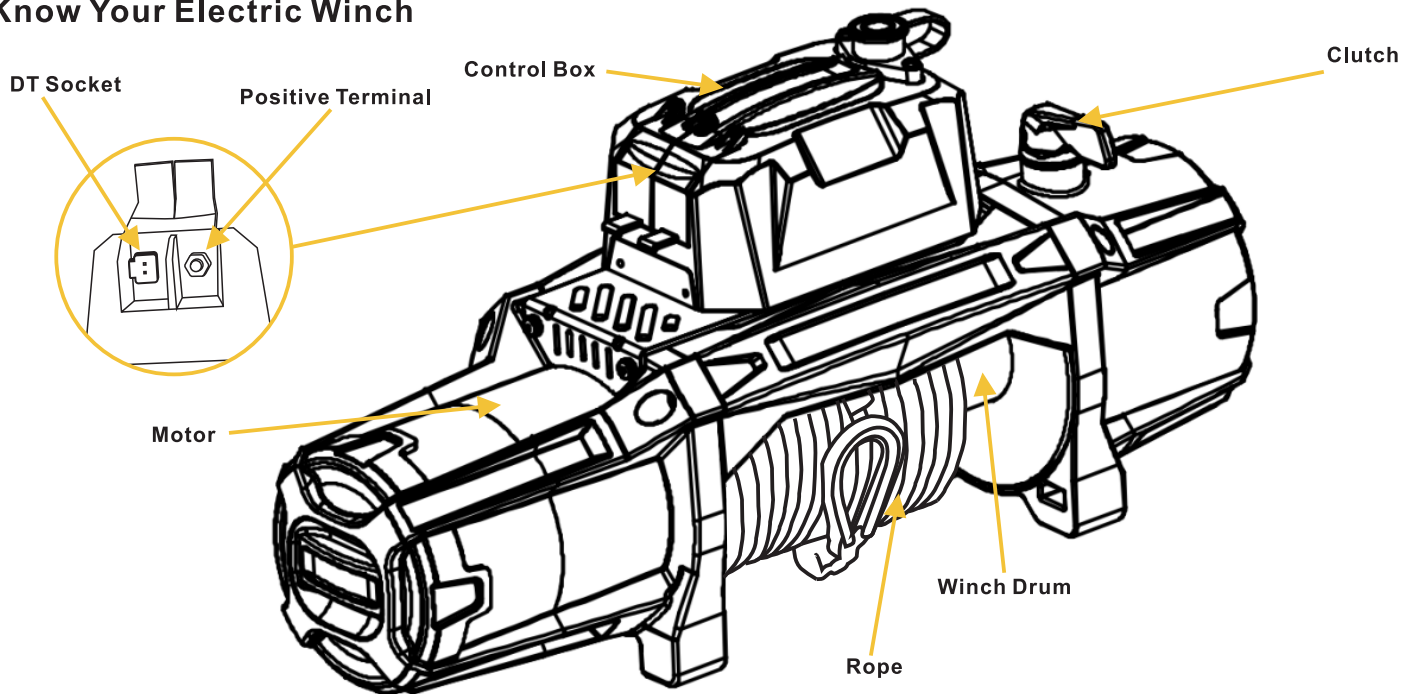

## Know Your Wireless Remote

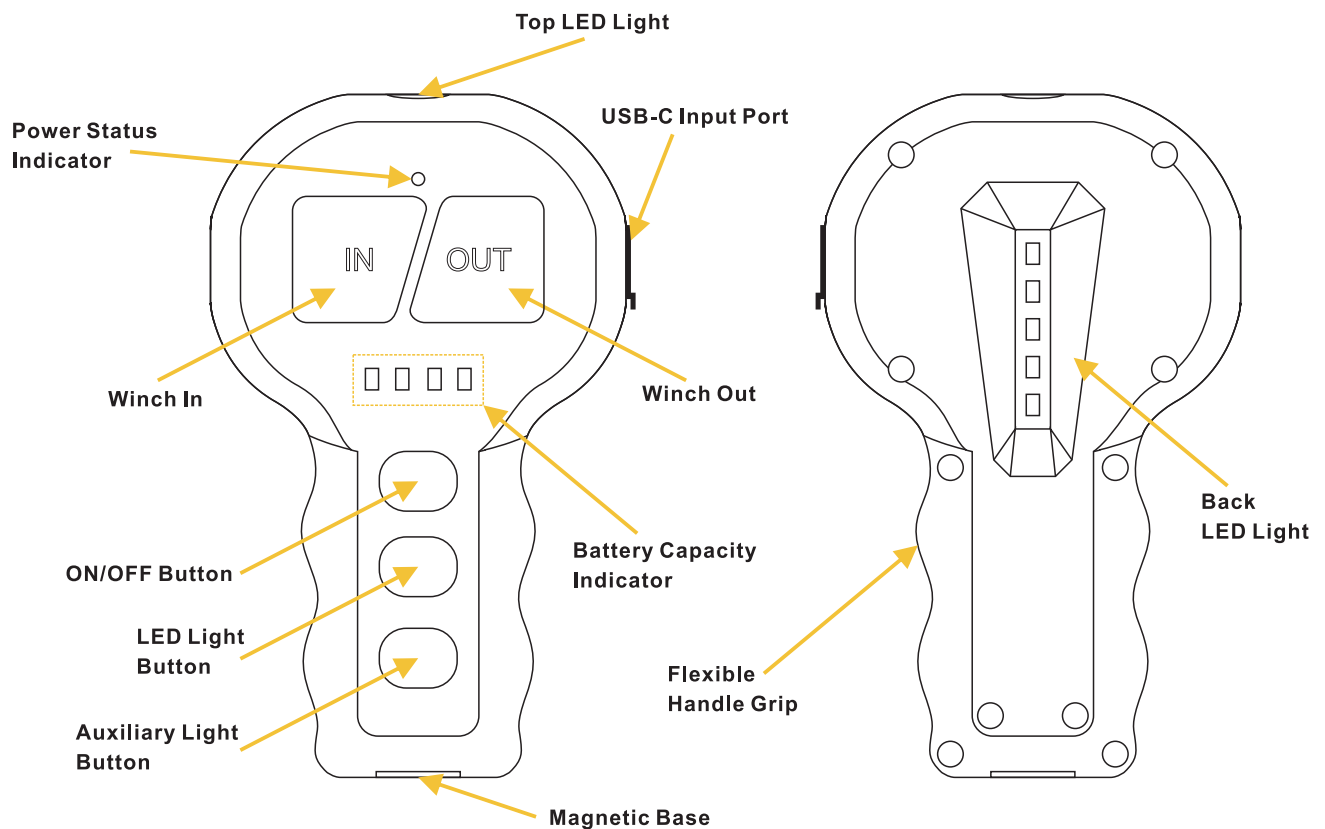

### **Button Function:**

#### **ON/OFF Button:**

When the remote control is powered off, all the indicator lights are off.

Long press the button to start the remote control, the red power status indicator will remain lit. The blue battery level indicator light also remains continuously illuminated, with each light indicating 25% battery level respectively.

#### **IN/OUT Button:**

When the "IN" / "OUT" button is pressed, the red indicator light starts flashing, accompanied by an audible relay activation sound emitted by the receiver. Releasing the button is followed by the relay deactivation sound.

#### **Mode Button:**

To select your preferred lighting scenario, simply press the LED light mode button.

#### **Auxiliary Light Button:**

To use your auxiliary light (not included), connect it to the DT socket on the control box and turn it on/off by pressing the button.

### **Automatic Shutdown**

When the LED light is turned off, the remote control will automatically shut down if there is no operation on it within 60 seconds.

## **WINCH MOUNTING INSTRUCTIONS**

Ensure that the mounting plate is rated to support at least the capacity of the winch.

Position the winch perpendicular to the vehicle's center line at the desired location. Mark the holes on the winch base, and compare their dimensions for accuracy.

Prior to drilling, thoroughly inspect the installation surface to ensure there are no hidden components or structural elements that may be damaged during the mounting process.

Drill holes at the marked locations, making sure they are appropriate for the recommended hardware. Securely install the winch using the hardware specified in the provided specifications.

# ENHANCING WINCHING EFFICIENCY:

## TIPS AND TECHNIQUES

1. **Avoid Angled Pull:** Do not engage in angled pulls during winching operations. Ensure that the winch line maintains an angle no greater than 15 degrees above or below horizontal, or 45 degrees left or right from the straight-ahead position.

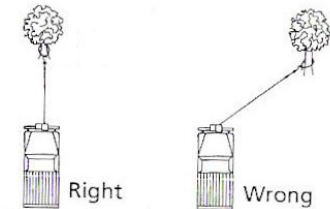

2. **Use Pulley Blocks:** Use a pulley block to exert a smaller force to move a heavier resistance or object. Pulley blocks enhance the winching process by increasing mechanical advantage.

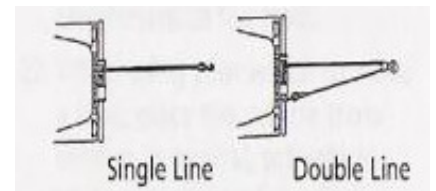

3. **Use Dampener:**

(1) Place the dampener in an unobstructed position on the ground, aligning it with the winch line. Do not approach a tensioned winch line. Prior to dampener installation, the line should be slack.

(2) Fold the dampener over the cable, positioning it within the central third of the line's length. Then fasten it.

(3) If feasible, fill the external pockets with loose sand; using rocks or stones in the dampener's ballast pockets is strictly prohibited.

(4) Before applying tension to the line, ensure all individuals, animals, and assets are situated at a safe distance away from the line pull area.

(5) While pulling in the cable, potential adjustment of the dampener's placement might be necessary. Always release tension from the line before approaching and performing any modifications.

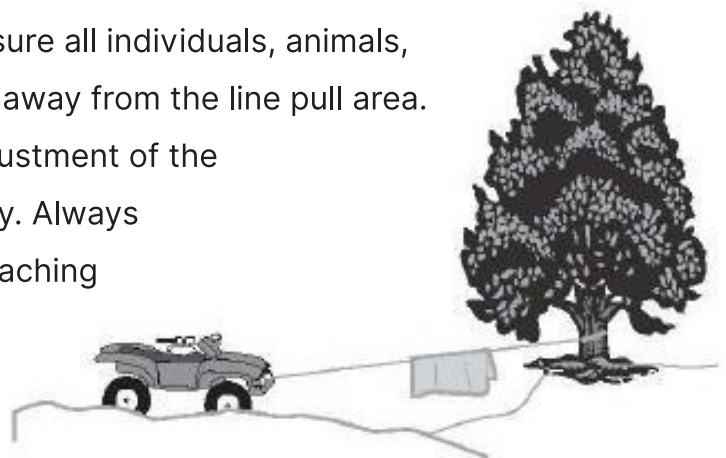

## WIRING DIAGRAM:

1. Plan a secure and protected wiring route from the vehicle's mounting point or intended area for the winch to the battery. Ensure that the wiring is kept away from moving parts, road debris, and potential damage caused by vehicle operation or maintenance.
2. If drilling through the bumper or any body part is necessary for wire routing, it is recommended to install a rubber grommet in the hole to prevent wire fraying at that location.
3. Establish the cable pathways from the control box to the battery and from the control box to the winch.
4. Connect the wires from the control box to the corresponding terminals on the winch.
5. Connect the long black battery cable from the corresponding terminal on the winch to the battery.
6. Install the circuit breaker on the positive terminal of the battery (recommended).
7. Attach the long red battery cable to the circuit breaker (recommended).

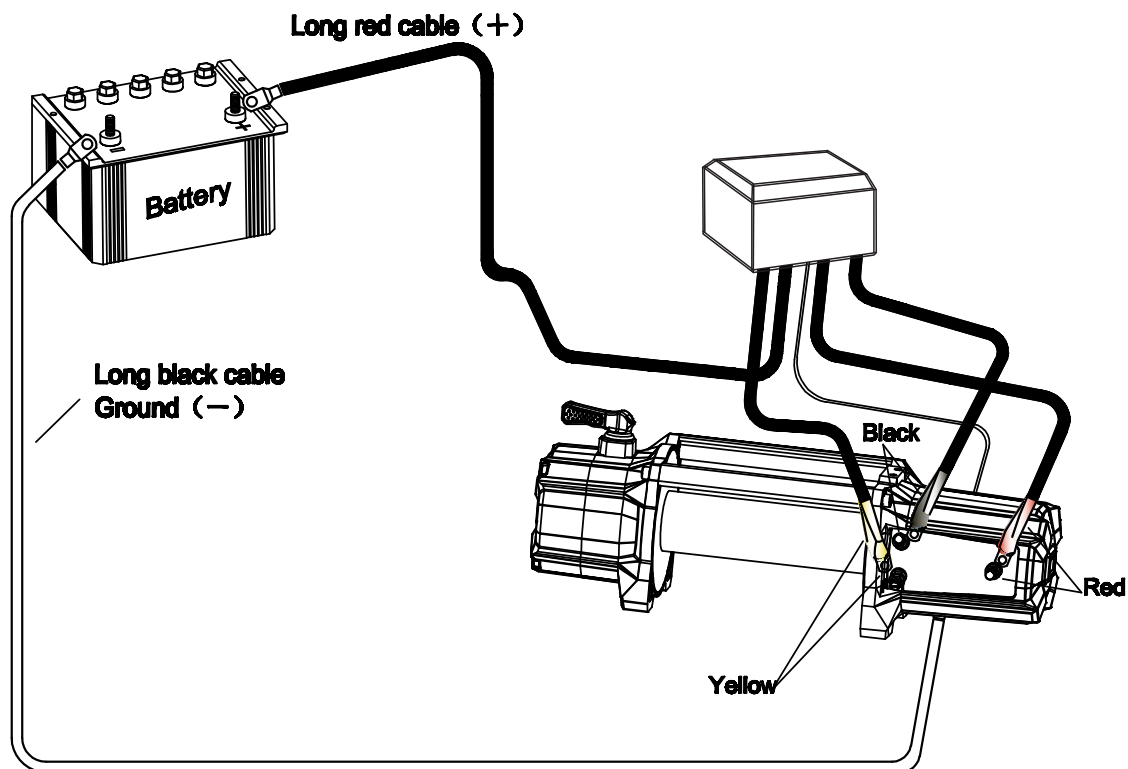

**Note:** The wired and wireless mode could be used simultaneously.

## TROUBLESHOOTING:

PROBLEM	SUGGESTED SOLUTION
Rope only retracts	<ol style="list-style-type: none"> <li>1. Check if the wiring is reversed, as this can cause such a problem.</li> <li>2. If the wiring is correct and the issue persists with both wired and wireless operation, it could indicate a relay malfunction.</li> <li>3. If the rope retracts properly with a wired controller but not with a wireless controller, it might be due to the receiver's positive and negative wires being mistakenly connected or the power wires (red and black) being reversed.</li> </ol>
Rope only extends	First, ensure that the wiring is correctly connected. If the wiring is correct, it is possible that the receiver's positive (or negative) wire is connected to the positive (or negative) wire of the power source.
Winch fails to operate	First, verify the correct wiring connections. Then, test if the winch functions with a wired controller and also with a wireless controller.
Unexpected automatic winch activation	It is possible that the winch's remote control frequency coincides with another electrical device, resulting in unintended activation.
Rope breakage	Has the load exceeded the maximum weight capacity of the rope?

## WARRANTY

BUNKER INDUST warrants to the original purchaser that the electric winch shall be free from any defects in both material and workmanship. This warranty shall extend for a duration of two (2) years, three (3) years, and one (1) year, for the electrical components, mechanical components, and synthetic rope of the winch, respectively, starting from the date of the original purchase. This warranty is applicable exclusively to the original purchaser of the winch. To obtain any warranty service, you must provide BUNKER INDUST with acceptable proof of purchase and the purchase date, such as a copy or screenshot. BUNKER INDUST, at its sole discretion, will undertake repair, replacement, or refund the purchase price of the defective winch or component, as long as you submit your claim within the warranty period.

### Exclusions:

This warranty does not cover:

1. Finish and paint.
2. Damage caused by accidents, abuse, misuse, collision, overloading, modification, misapplication, improper installation, or improper servicing.
3. Normally wearable parts, such as the brake mechanism.
4. Removal or reinstallation of the winch.

This warranty becomes null and void if any BUNKER INDUST serial number is removed or defaced. Commercial or industrial use, hoisting applications, or any misuse of the winch renders the warranty void unless specifically agreed to in writing by BUNKER INDUST.

### Claims:

The aforementioned warranty is the only warranty provided. There are no other warranties, whether expressed or implied, including implied warranties of merchantability or fitness for a particular purpose. No BUNKER INDUST dealer, agent, or employee is authorized to modify, extend, or add to this warranty. BUNKER INDUST shall not be held liable for any special, indirect, incidental, or consequential damages (including, but not limited to, lost profits, downtime, or loss of use) under any legal theory, even if BUNKER INDUST was informed of the possibility of such damages.

BUNKER INDUST reserves the right to make changes to the product design without prior notice. In cases where BUNKER INDUST has made changes to a product's design, BUNKER INDUST is not obligated to upgrade or modify previously manufactured products.