

Product Specification

Sketch										Desk thickness	
Item	Monitor size	Weight range (lbs)	Lift	Tilt	Swivel	Pivot	VESA	Packing size (in)	N.W(lbs)	Grommet	Desk clamp
Specification	≤30°	4.4-22	13 3/8"	+75°~ -45°	±90°	±90°	3**3"	18.7* 7.7* 5.5	7.7	2 3/8"	2"
							4**4"				

Product Size (mm)

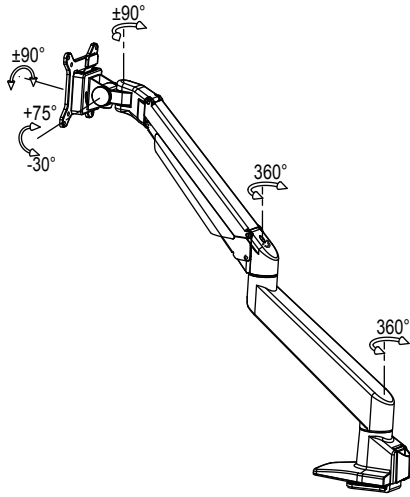
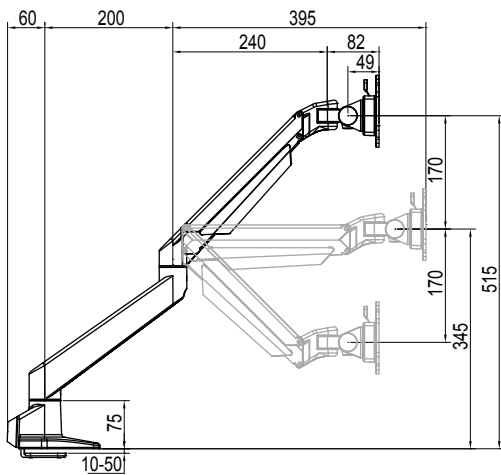

Installation – Desk Clamp

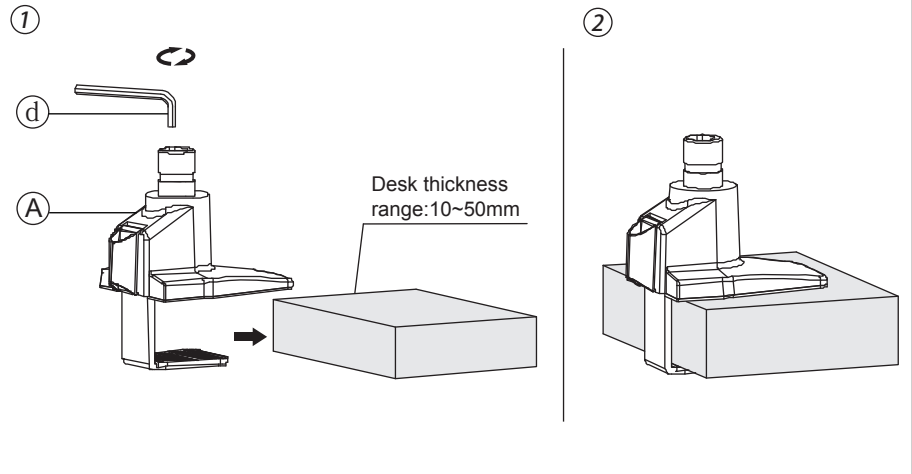

Installation – Grommet

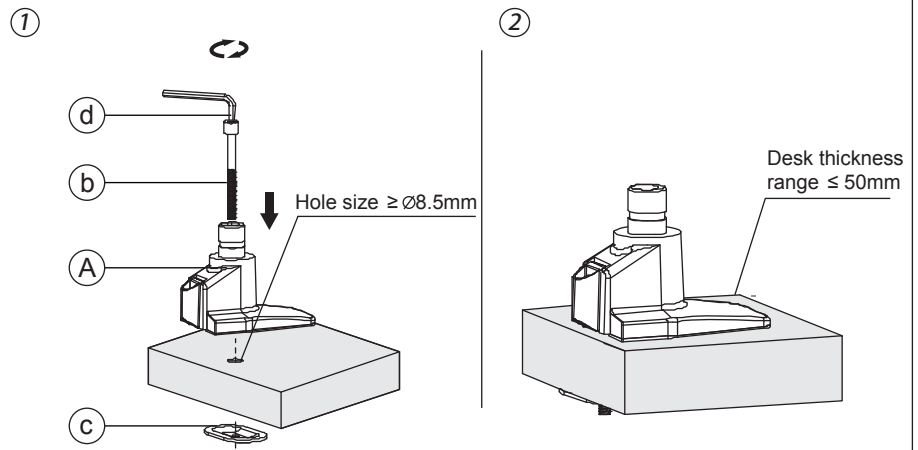

Install Procedure

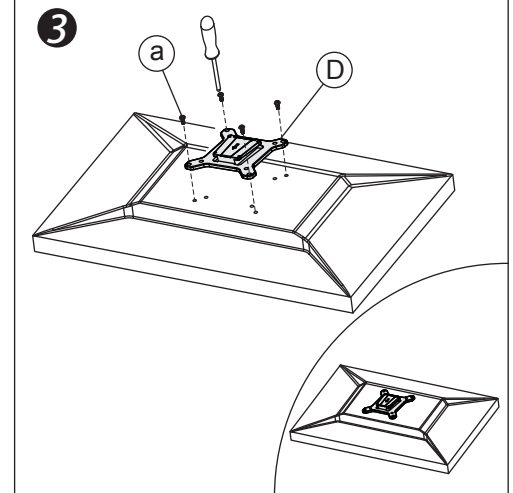
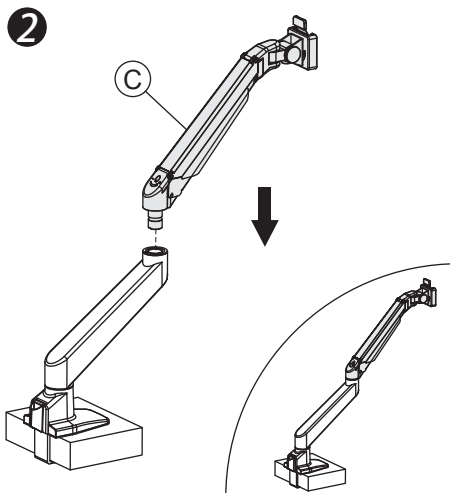
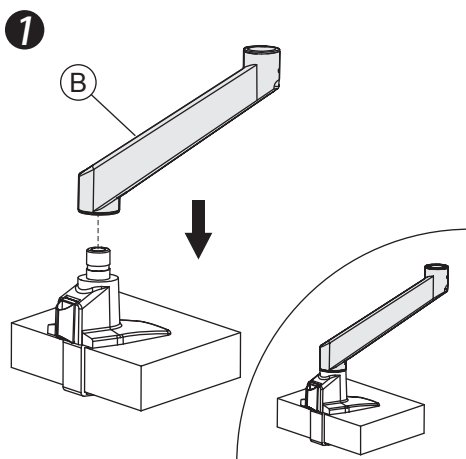

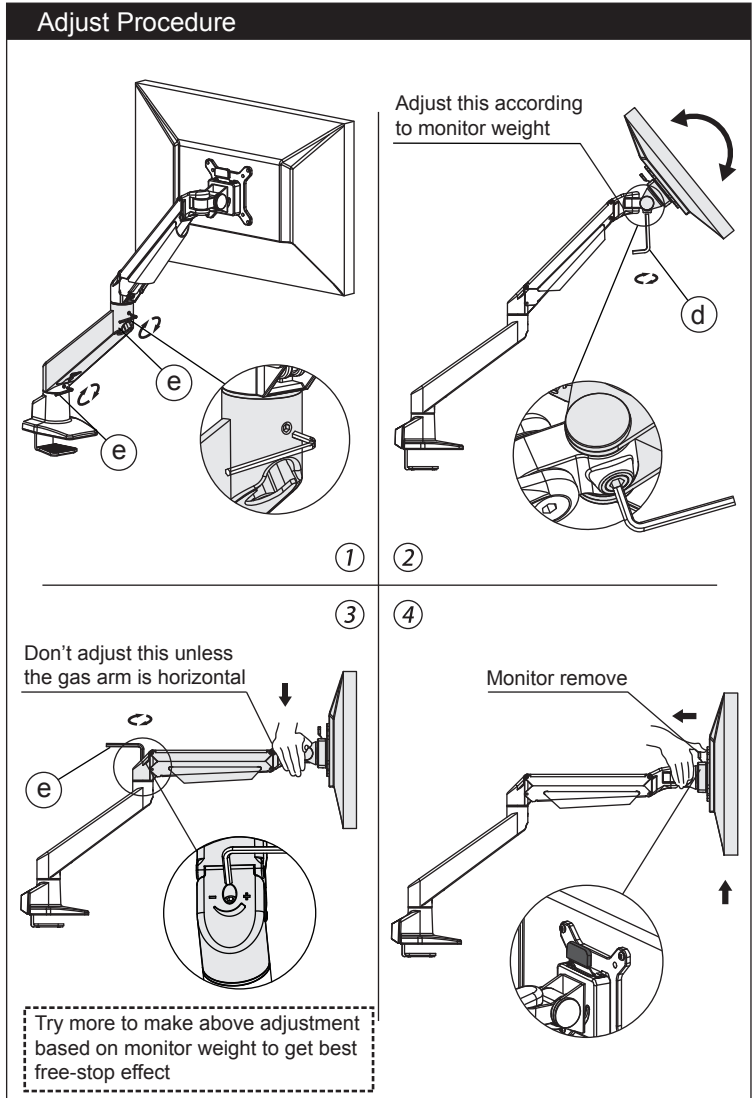
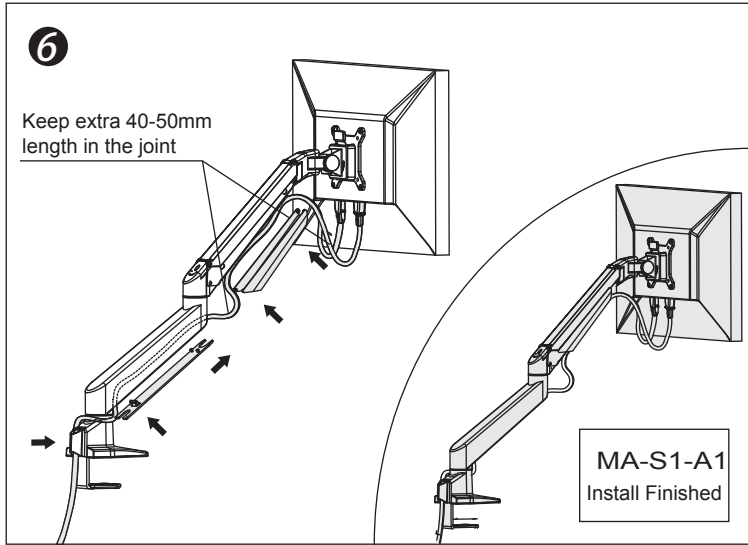
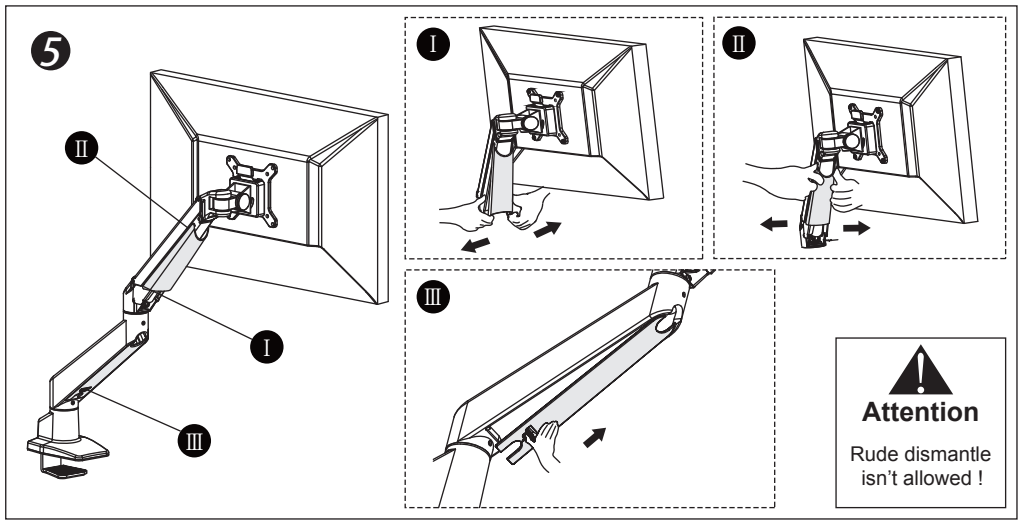
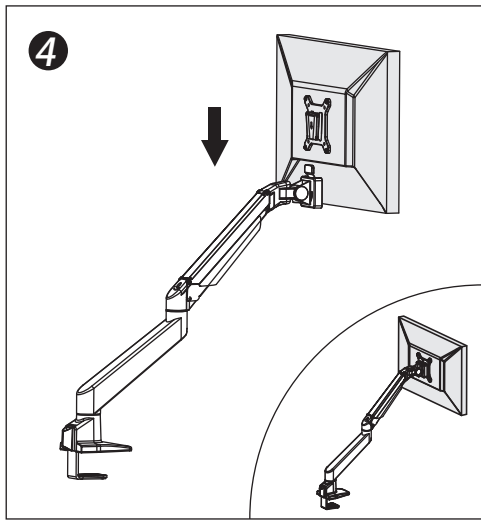

Module List			
No.	Sketch	Specs	Quantity
A			1
B			1
C			1
D			1

Part List			
No.	Sketch	Specs	Quantity
a		M4x12	4
b		M8x160	1
c			1
d		M6	1
e		M4	1