

OAHU

FREESTANDING BATHTUB

Proudly Handcrafted in the USA

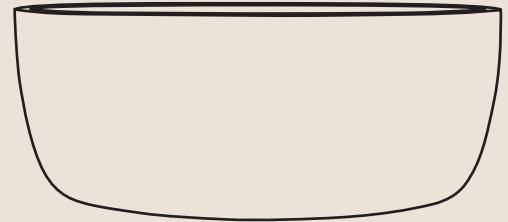

PLAN VIEW

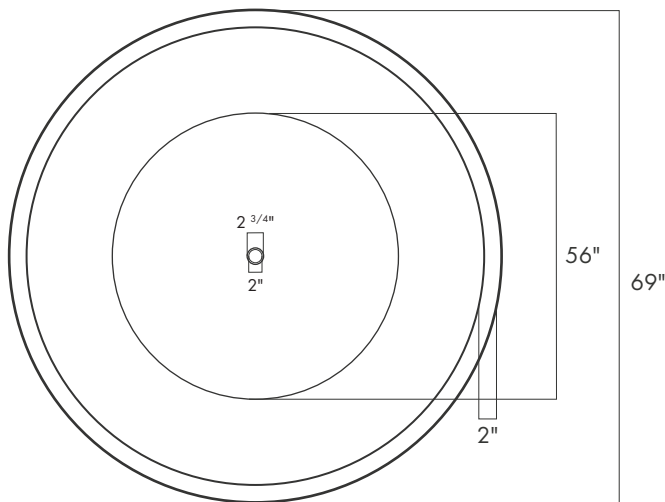

SECTION VIEW

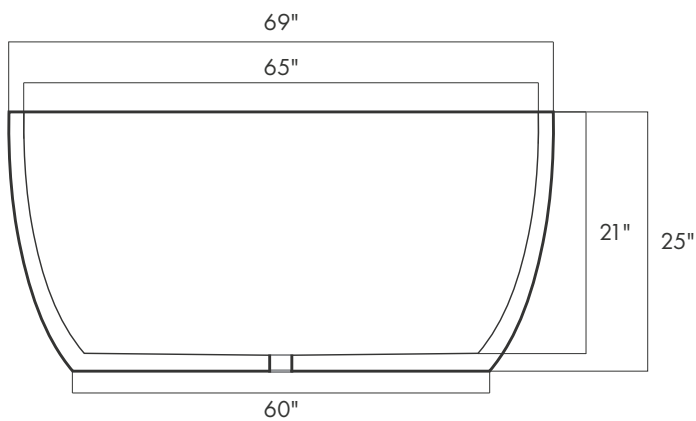

SPECIFICATIONS

Weight: 1100 lbs. (498 KG)

Material: Fiber Reinforced Concrete.

Dimensions: 69" x 69" x 25"
(1752.6mm x 1752.6mm x 635mm)

Finish: High Performance Waterproof Sealer.

Warranty: 1 Year Structural Warranty.

Water Capacity: MAX 265 Gallons

COLORS AVAILABLE



Concretti Designs
www.concrettidesigns.com
info@concrettidesigns.com
702.444.7711



Note that all measurements are approximate due to the handcrafted nature of our products. We recommend waiting to receive your Concretti Designs products before installing wall mounting brackets or cutting into cabinetry. Please expect slight variation in colors.