

A handcrafted concrete planter that features an asymmetrical design, perfect for indoor & outdoor use, available in three sizes that work beautifully as a set or individually. Featuring our uniquely engineered concrete formula that includes fiberglass reinforcement that offers strength and durability while giving a lightweight feel to the product.

AVAILABLE SIZES

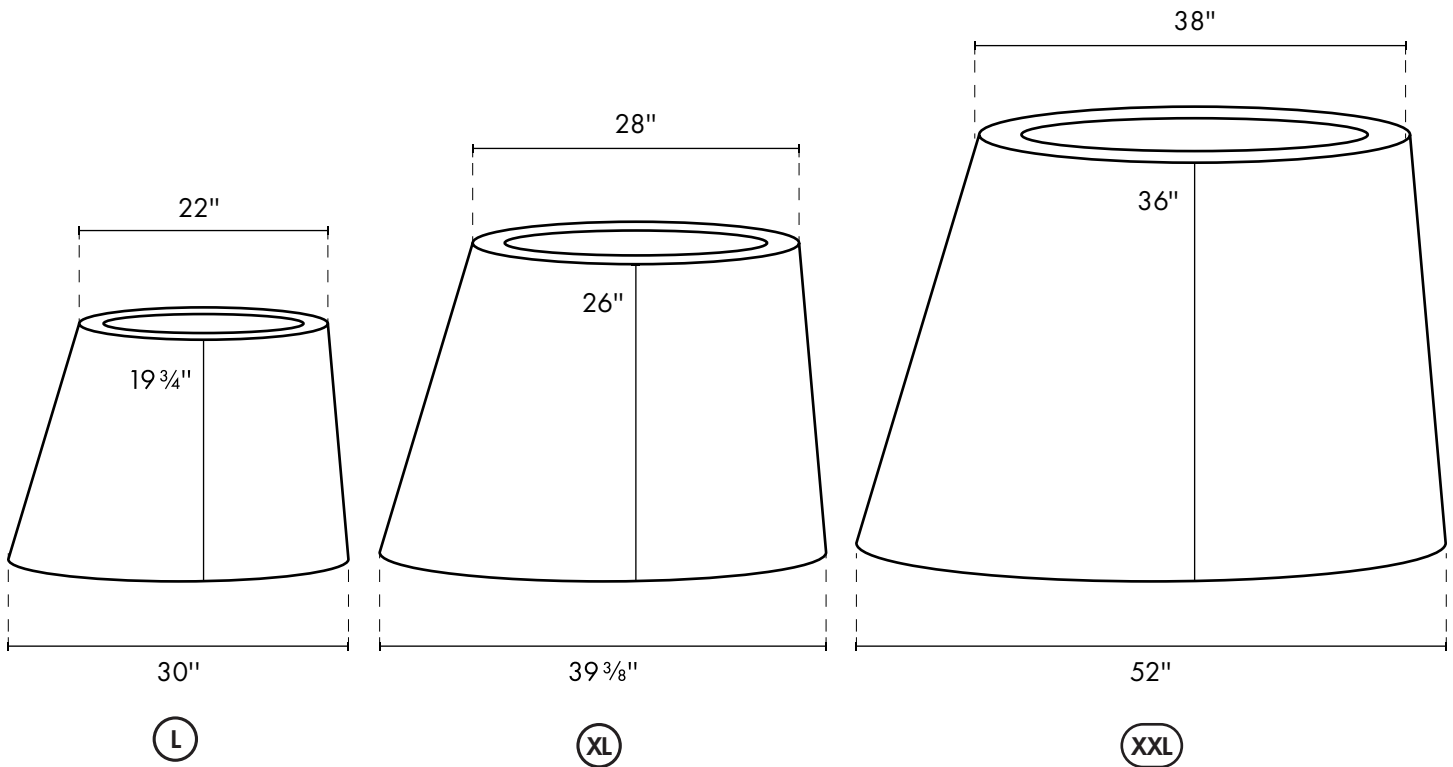

SIZING



SIZE	DIMENSIONS (W×H)	DIAMETER (UPPER)	DIAMETER (LOWER)	WEIGHT
Large	30" × 19 3/4"	22"	30"	165 lb.
X Large	39 3/8" × 26"	28"	39 3/8"	330 lb.
XX Large	52" × 36"	38"	52"	660 lb.

Note that all measurements are approximate due to the handcrafted nature of our products. Please expect slight variation in colors.

## SCALE

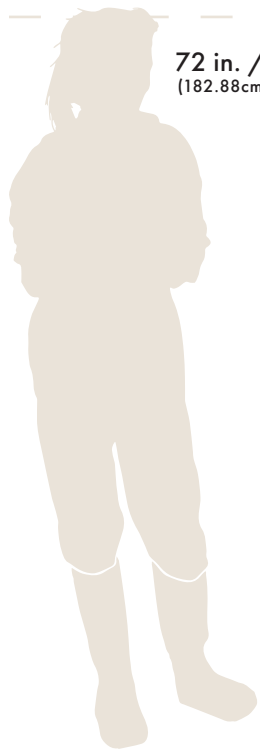

72 in. / 6 ft.  
(182.88cm)

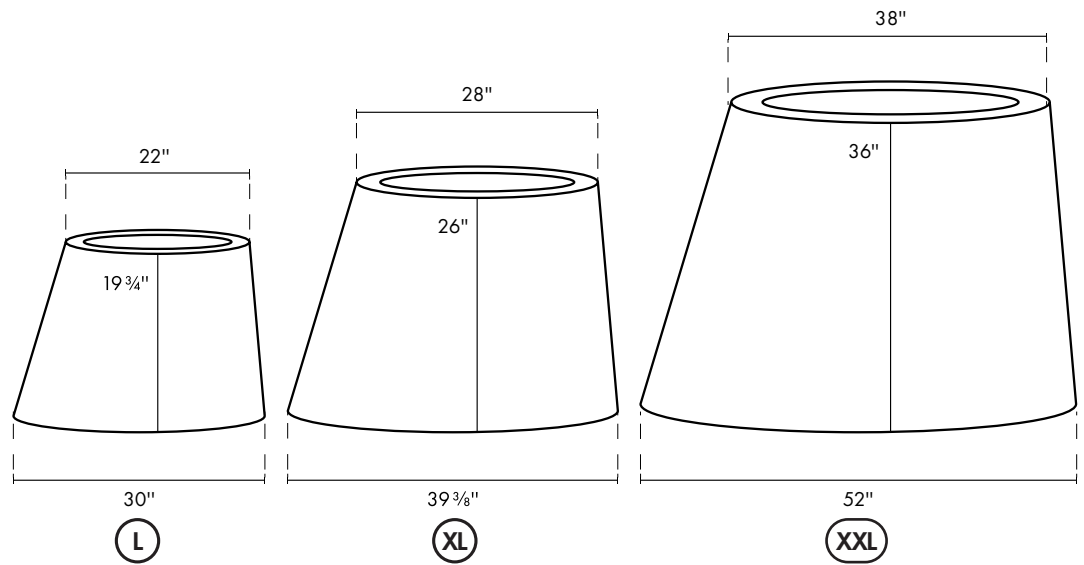

## INTERNAL

### TOP

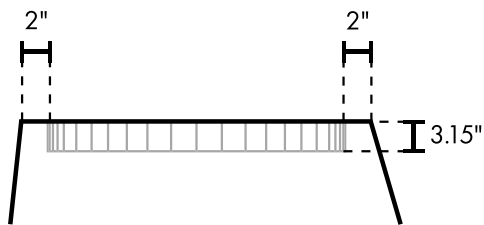

### DRAINAGE HOLE + BASE

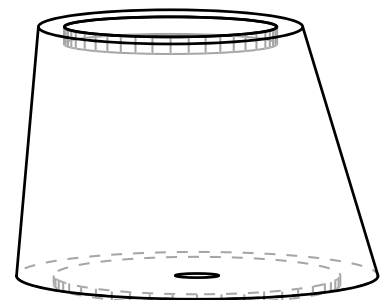
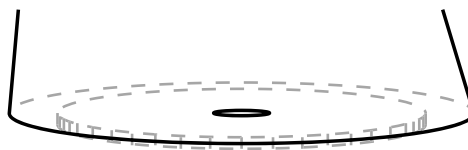

## MORE INFO

**MATERIAL**      Fiberglass Reinforced Concrete

**DRAINAGE HOLE**      Included

### COLORS



**WARRANTY**

**USAGE**

1-Year Structural Warranty

Indoors & Outdoors

Note that all measurements are approximate due to the handcrafted nature of our products. Please expect slight variation in colors.