

BONSAI

PLANTER

CONCRETI

A handcrafted concrete planter that features a spherical design, perfect for indoor & outdoor use, available in five sizes that work beautifully as a set or individually. Featuring our uniquely engineered concrete formula that includes fiberglass reinforcement that offers strength and durability while giving a lightweight feel to the product.

AVAILABLE SIZES
 (XS) (S) (M) (L) (XL)

SIZING

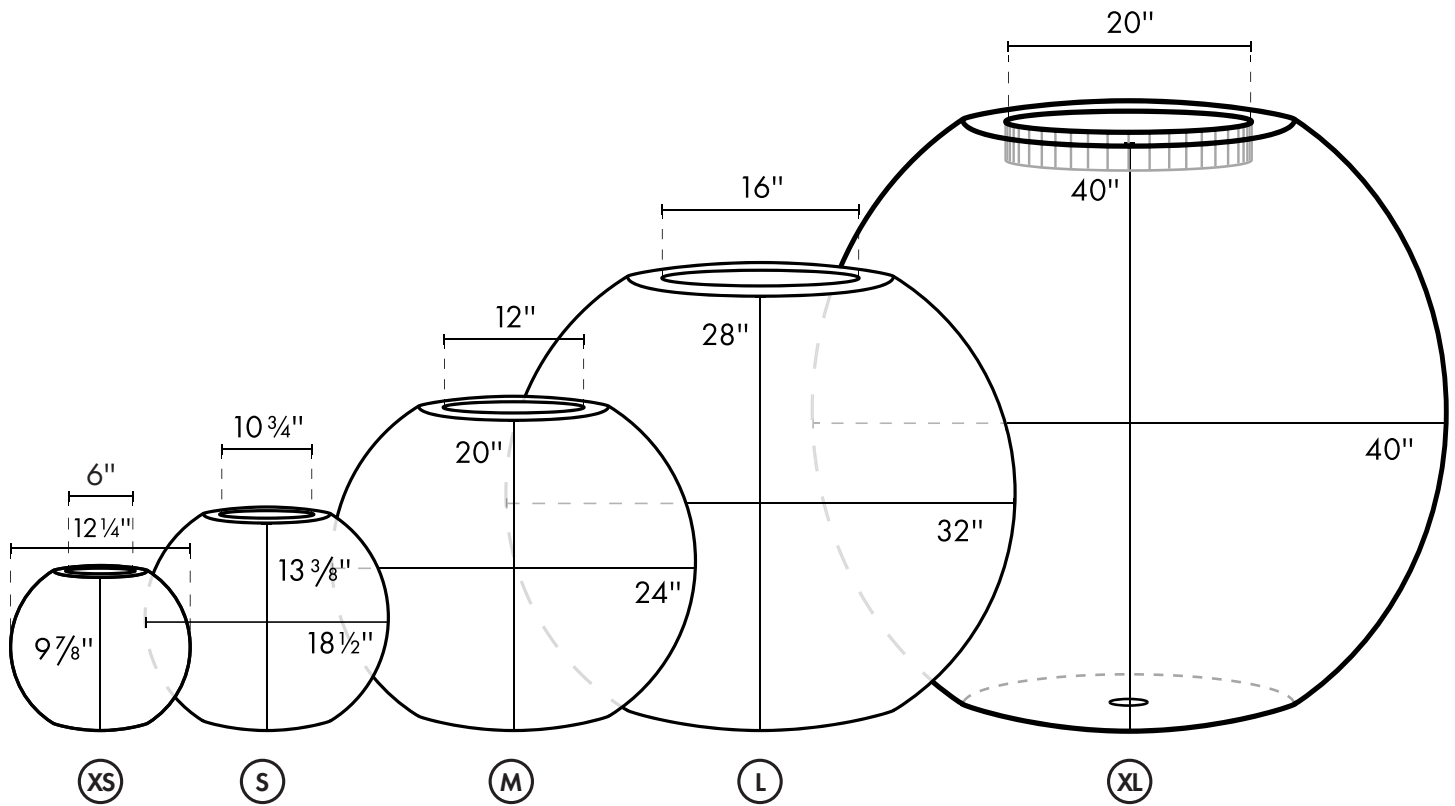

SIZE	DIMENSIONS (W×H)	DIAMETER (OPENING)	DIAMETER (WIDTH)	WEIGHT
Extra Small	12 1/4" × 9 7/8"	6"	12 1/4"	25 lb.
Small	18 1/2" × 13 3/8"	10 3/4"	18 1/2"	41 lb.
Medium	24" × 20"	12"	24"	110 lb.
Large	32" × 28"	16"	32"	187 lb.
Extra Large	40" × 40"	20"	40"	330 lb.

Note that all measurements are approximate due to the handcrafted nature of our products. Please expect slight variation in colors.

SCALE

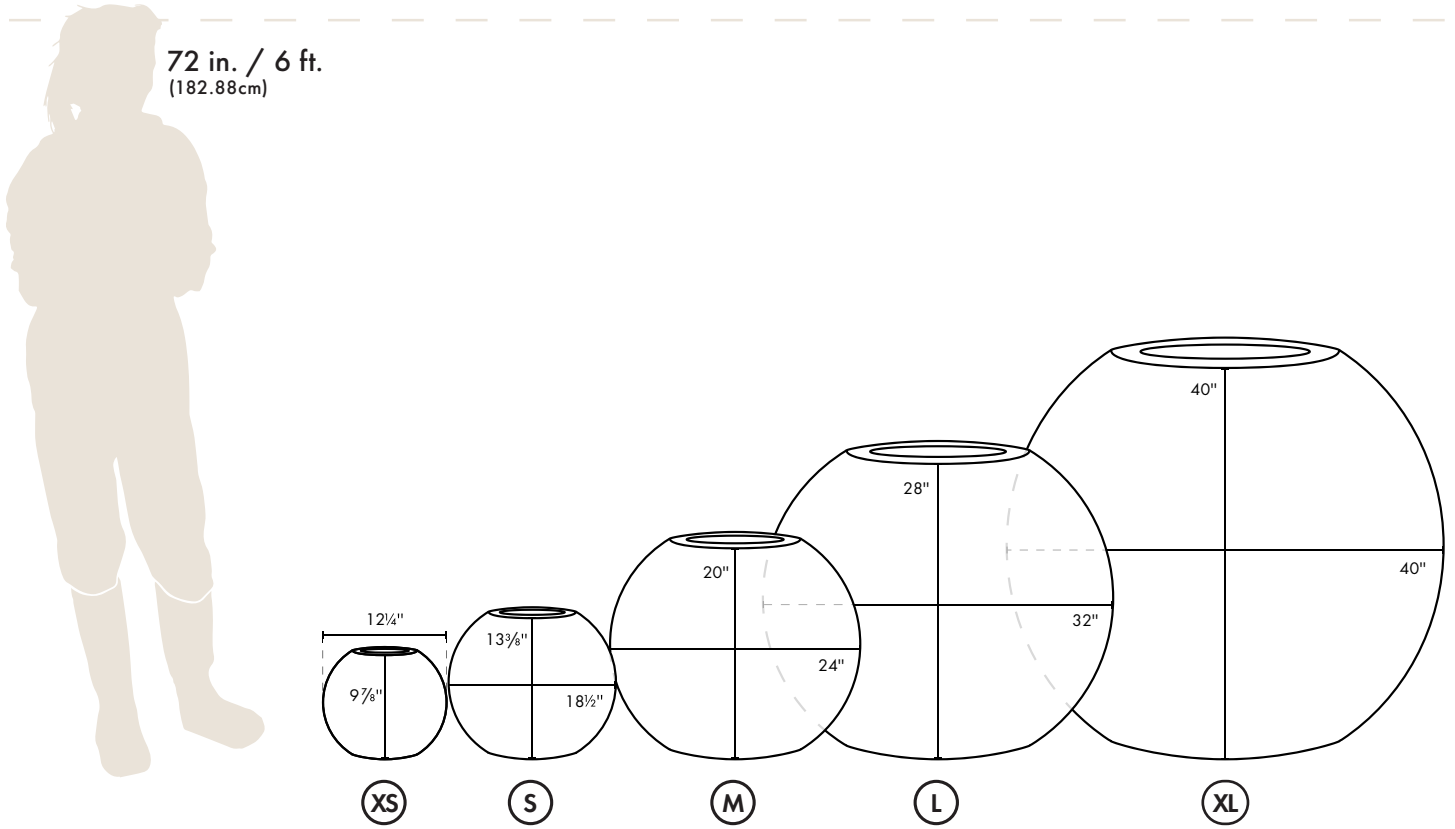

INTERNAL

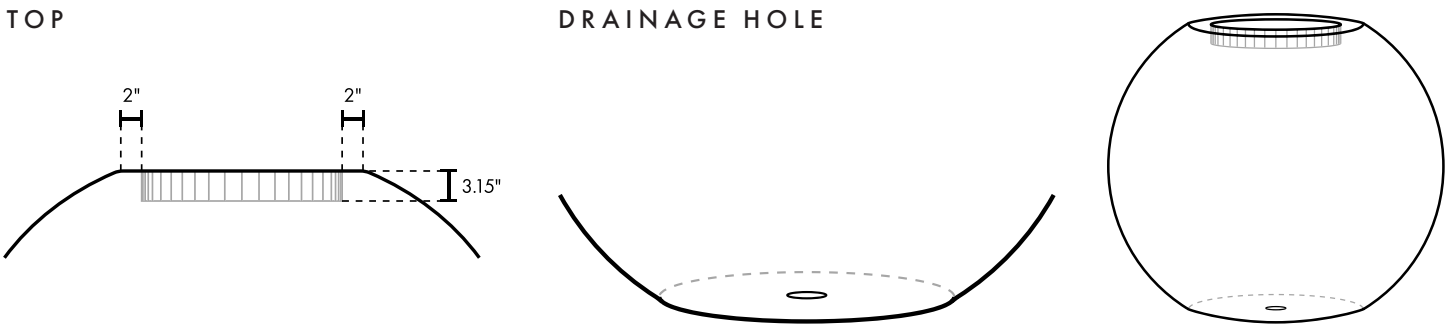

MORE INFO

MATERIAL Fiberglass Reinforced Concrete

DRAINAGE HOLE Included

COLORS



WARRANTY

1-Year Structural Warranty

USAGE

Indoors & Outdoors

Note that all measurements are approximate due to the handcrafted nature of our products. Please expect slight variation in colors.