

# vft3 Helmet

Certified - Model: VF3 WILDFIRE

Ergonomics and versatility  
with a high level of protection.

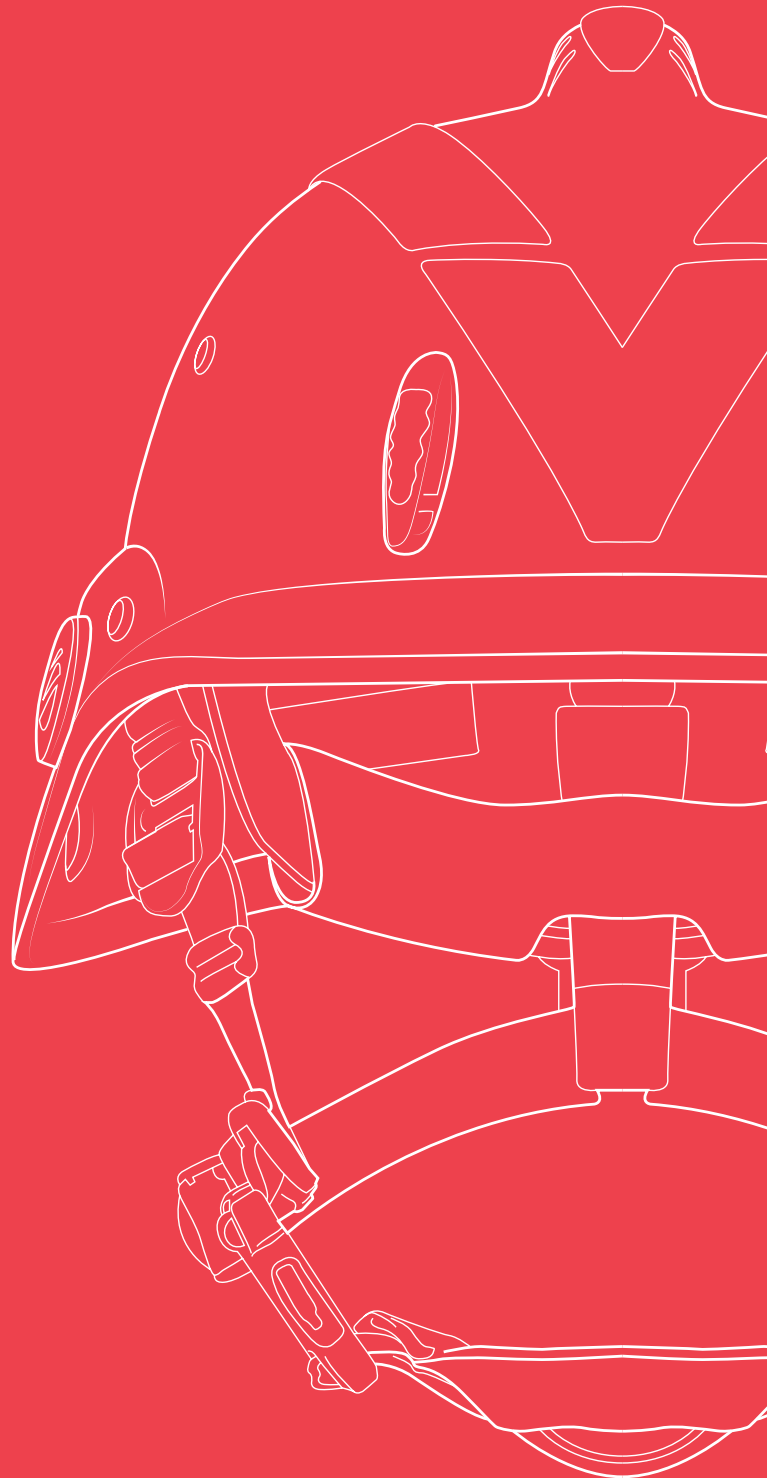

# vft3 Helmet

Ergonomics and versatility with a high level of protection.

The **vft3 Helmet** was designed to meet the needs of units that intervene in wildland fires and rescue operations. Made with high-quality materials, it offers a high level of protection with a wrap-around design produced in a single PC/ABS part without added paint and a protective visor for more protection against liquids from aerial discharges with flame retardant.

## Greater protection and resistance

A wrap design for better protection from side, front and rear impacts manufactured with one sole PC/ABS part, without any added paint.

## More comfortable and breathable

Completely size adjustable with an adjustment wheel<sup>1</sup>. The breathable and fireproof cushioned leather pads form a totally ergonomic and comfortable harness.

## Customization

A large variety of colors available, reflective strips with marking and the possibility of adding a shield.



### Standards

NFPA 1977:16

Standard on Protective Clothing and Equipment for Wildland Fire Fighting

### Technical specifications

Shell material	PC/PBT.
Inner material	Breathable leather.
Available colors	Yellow, orange, red, gray, black, white, blue and green.
Sizes	Adjustable from 52-64 cm.
Dimensions	27.7 x 24.5 x 16.4 cm.
Weight	600 g.

# 1 Shell

## Features

- Made of PC/PBT.
- The color is integrated with the injection of the material. No added paint.
- Available colors: yellow, orange, red, gray, black, white, blue and green.
- Reflective strip colors: yellow.
- Customization. Reflective strips with marking and the possibility of adding a shield.

### Reflective strip color



### Colors



# 2 Harness

Inner harness with 6 anchoring points to the shell. A multi-size system with an adjustment wheel in the back for adaptation to any head.

## Features

- Size adjustment with an adjustment wheel from 52-64 cm.
- Ergonomic crown pad.
- Cushioned and breathable leather.
- Replaceable and washable protective textile.



# 3 Chin Strap

Made of fire-retardant fabric and leather. 3-point anchoring to the shell.

## Five adjustment points:

- 1 Neck perimeter adjustment.
- 2 Ear height adjustment.
- 3 Height adjustment.
- 4 Sliding removable chin strap.
- 5 Adjustable chin guard.



### Raised view

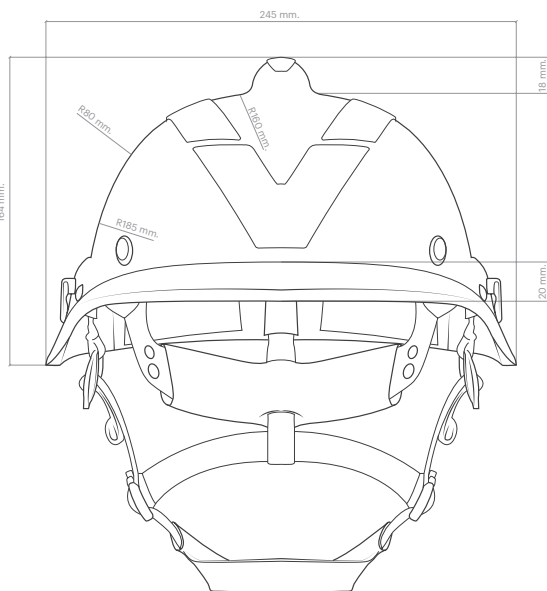

### Profile

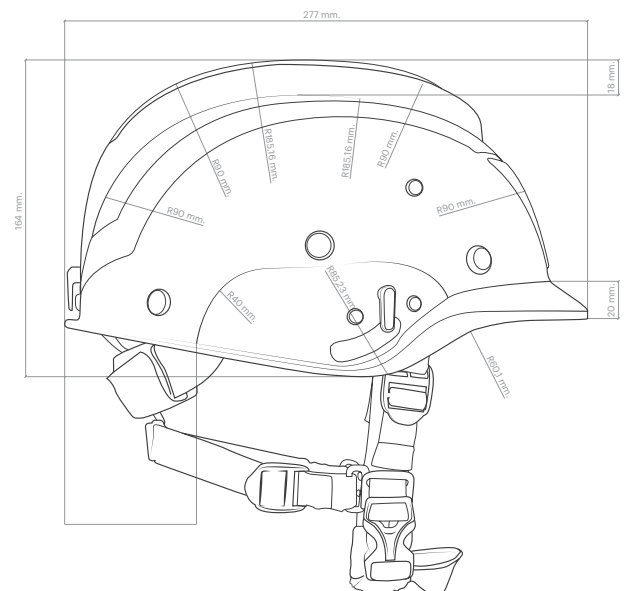

## 4 Compatibility with accessories

The vft3 helmet is compatible with all types of accessories. Noise protection, nape guards, radio systems and video cameras can be included.

### Front mount LED

- Front-guided handsfree lighting.
- Secured to the shell via 4 anchoring points.



### Watertight protective goggles with ventilation.

- Certified goggles with the helmet (vft Goggles).
- Protection against impacts, smoke, high temperatures, dust, wind and UV radiation.
- Inner anti-fog lens treatment and anti-scratch outer finish.



### Chainsaw Kit

- Protective screen against any type of impact caused by the use of a chainsaw.
- Specific anchoring via the anchoring points.
- Noise protection.



### LED flashlight

- Front-guided handsfree lighting.
- Secured to the shell via universal anchoring.
- A variety of flashlights and adaptors available depending on the use.



### Short and long protective screen

- Protective screens of different sizes.
- Protects the eyes and face.



### Nape guard

- Nape guard made of 65% Lenzing® F.R. | 30% Nomex® | 5% Kevlar® for perfect insulation against radiation and high temperatures.
- Light.
- Breathable.
- Velcro® attachment.



\* Useful life: 5 years

\* Warranty: 2 years for the helmet and accessories

Any questions? Contact us: [clientes@vallfirest.com](mailto:clientes@vallfirest.com) | T. +34 938 678 779