

Product Information

Materials of Construction

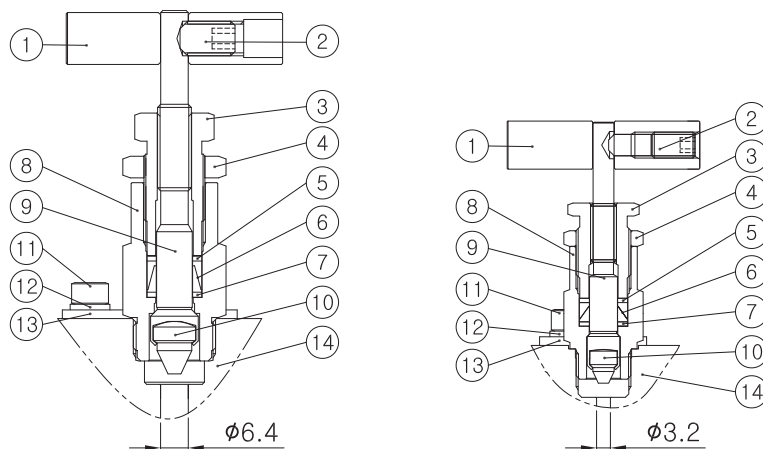

Component	Valve Body Materials	
	Stainless Steel	Carbon Steel
	Bonnet Valve	
	Grade/ASTM Specification	
1.Handle	Stainless steel	Aluminum black anodized
2.Set screw	S316 / A276 or A479	S316 / A276 or A479
3.Packing bolt		C.Steel / A108
4.Lock nut		S316 / A276 or A479
5.Upper gland		
6.Packing	Standard chevron PTFE packing, optional Graphite	
7.Lower gland	S316 / A276 or A479	S316 / A276 or A479
8.Bonnet		C.Steel / A108
9.Stem		S316 / A276 or A479
10.Non-rotating stem tip	S630 / A564	
11.Lock plate bolt	Stainless steel	
12.Spring washer	Stainless steel	
13.Lock plate	Stainless steel	Carbon steel
14.Body	S316 / A276 or A479	C.Steel / A108 or A105 Yellow zinc alvanized
Flange seals (not shown)	PTFE / D1710, optional Graphite and Fluorocarbon FKM O-ring	
Flange bolts (not shown)	Stainless steel / A193	Carbon steel / A193
Lubricant	Fluorinated base with PTFE and tungsten disulfide	
	Hydrocarbon based	

Product Information

Features

- Non-rotating stem tip at closure for long-life and leak-tight shutoff. Blunt VEE tip.
- Exclusive 2-piece, chevron PTFE packing design provides far improved sealing integrity. Grafoil packing optional.
- Isolated Threads : Packing located below the threads prevents media contamination and thread lubricant washout.
- Packing under the stem threads is to isolate the threads from the system fluid and lubricant washout.
- Packing bolt permits stem packing adjustment.

Features

Body Material	Packing Material	Temperature Range	Pressure Rating @100°F	Pressure Rating @Max. Temperature
Stainless Steel	PTFE	-54~232°C (-65~450°F)	413bar (6,000 psig)	4,130psig @450°F (285bar @232°C)
	Graphite	-54~648°C(1) (-65~1,200°F)		1,715psig @1,200°F (118bar @648°C)
Carbon Steel	PTFE	-29~176°C (-20~350°F)	413bar (6,000 psig)	5,230psig @350°F (360bar @176°C)
	Graphite	-29~176°C (-20~350°F)		



(1) Graphite packing rating is limited to 537°C(1,000°F) with flange end connection. In air, Graphite rating is limited 523°C (975°F), in steam it can go up to the maximum temperature of 648°C (1,200°F).

- -28 to 204°C (-18 to 399°F) with optional fluorocarbon FKM flange seal.

Testing

- Each instrument manifold is tested with nitrogen@1,000 psig (69 bar) to max. leak rate of 0.1 (SSCM).
- Hydrostatic shell test is performed at 1.5 times the working pressure as an option.
- Other tests are available upon request

Sour Gas Service

- For the use of valves on sour gas, materials for wetted components are selected in accordance with NACE standard as MR0175, latest revision.

How to Order Manifolds with Options

- To order the optional Grafoil packing, add-GF to the ordering number. SM3V-F-8N-GF-S6
- To order sour gas service valve, add-SG to the ordering number. SM3V-F-8N-GF-SG-S6
- To complete the ordering number, select valve body material designator -S6 for S316, -CS for carbon steel, Example: SM3V-F-8N-S6
- Packing adjustment : Extreme or rapid temperature cycle may require packing adjustment to maintain a leak-free system. Tightening the Locknut on the bonnet is for the packing adjustment.

Product Information

2-Valve	3-Valve	5-Valve
For isolating, calibrating and draining Pressure gauges and transmitters.	For measuring flow or leveling, using a differential pressure transmitter.	For measuring flow or leveling, using a differential pressure transmitter. Gauge with bleeding, calibration and test function.
In operation, the block valve is normally open when the bleed valve is closed. To remove the instrument, close the block valve fist, and open the bleed valve to relieve pressure at the upstream of the block valve. For calibration, connecting a calibration gauge to the bleed port allows checking the calibration of the instrument without removing it from the installation.	In operation, both block valves are open while the equalizer valve is closed to read a differential pressure to the pressure gauge or transmitter. To zero the instrument, close the block valve first then open the equalizer valve which will adjust the instrument to zero. To remove the instrument, close block valves first, then unscrew the bleeding plug to relieve pressure between the manifold and instrument.	In operation, both block valves are open while the equalizer and bleed valves are closed to read a differential pressure to pressure gauge or transmitter. To zero the instrument, close block valves and bleed valve, and open the equalizer valve which will adjust the instrument to zero. For calibration, connect the bleed port to a pressure gauge to check the calibration of the instrument.

Ordering and Technical Information

Manifolds		Basic Ordering Number	End Connection		Orifice mm (in.)	Weight kg (lb.)
			Process	Instrument		
Remote Mount	Block	SM2V-F-8N	1/2 in. Female NPT		3.2 (.126)	0.8(1.8)
		SM3V-F-8N			6.4 (.251)	2.0(4.4)
		SM5V-F-8N				2.2(4.9)
Direct Mount	Single Flange	SM2V1-F-8N	1/2 in. Female NPT to Flange Flange design meets MSS SP-99.		3.2 (.126)	1.0(2.2)
		SM3V1-F-8N			6.4 (.251)	2.2(4.9)
		SM5V1-F-8N				2.7(6.0)
	Double Flange	SM3V2	Flange to Flange. Flange design meets MSS SP-99.		6.4 (.251)	2.5(5.5)
		SM5V2				2.7(6.0)
	Single Flange with slotted feature	SM2V1S-F-8N	1/2 in. Female NPT to Flange. Flange design meets MSS SP-99.		3.2 (.126)	1.0(2.2)
		SM3V1S-F-8N			6.4 (.251)	2.2(4.9)
		SM5V1S-F-8N				2.7(6.0)
	Double Flange with feature	SM3V2S	Flange to Flange. Flange design meets MSS SP-99		6.4 (.251)	2.5(5.5)
		SM5V2S				2.7(6.0)
	Vertical	SM2VD-F-8N	1/2 in. Female NPT to Flange, Flange design meets MSS SP-99.		3.2 (.126)	1.6(3.5)
		SM3VD-F-8N				6.4 (.251)
SM5VD-F-8N		3.3(7.3)				
SM5VDS-F-8N		2.7(6.0)				
SM5VDS-F-8N-CT						

- To complete the ordering number, select valve material designator.
-S6 for S316, -CS for Carbon steel. Example : SM2V-F-8N-GF-S6/CS
- To order optional Graphite packing, add -GF to the ordering number. Example : SM2V-F-8N-GF-S6
- To order sour gas service valve, add -SG to the ordering number. Example : SM2V-F-8N-GF-SG-S6

SM*V Series (Remote Mount)

SM2V-F-8N

