

SCA30 Series For working pressure up to 3000 psig(206bar)

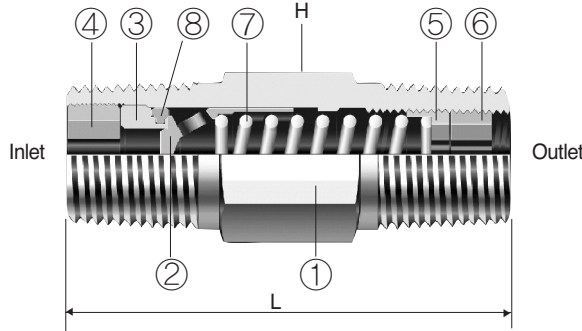

Materials of Construction

Item	Description	Valve Body Materials	
		S316	Brass
1	Body	S316 /A276, A479	Brass
2	Poppet		
3	Insert		
4	Insert Lock Screw		
5	Adjusting Screw		
6	Locking Screw		
7	Spring	S302/A313	
8	O-ring	Viton	NBR

* Silicone-based Lubricant for poppet.
Wetted parts are listed in orange color.

Features

- Pressure rating up to 3,000psig (206bar) @ 70°F(21°C).
- Temperature rating up to 375°F(191°C) with Standard Viton O-ring.
- Choice of materials : Standard S316 and Brass.
- Cracking pressure adjustable from 3 to 600psi (0.2 to 41.4 bar)
- Heat code traceability.
- Every valve is 100% factory tested for cracking and reseal.

• Spring Cracking Pressure Range Designator

Designator	Cracking Pressure	
	psi	bar
3	3 to 50	0.21 to 3.5
50	50 to 150	3.5 to 10.4
150	150 to 350	10.4 to 24.2
350	350 to 600	24.2 to 41.4

Ordering Information and Dimensions

Basic Ordering Number	Cv	End Connections			Dimensions mm (inch)	
		Size	I	Outlet	L	H
SCA1	0.35	1/4"		Female NPT	75.7(2.98)	3 / 4
		1/4"		Male NPT	41.1(1.62)	9 / 16
		1/4"		Male BSPT	41.1(1.62)	9 / 16
SCA2	1.20	1/2"		Male NPT	65.0(2.56)	7 / 8
		1/2"		Male BSPT	65.0(2.56)	7 / 8

To order, add a cracking pressure range designator to the basic ordering number and then specify valve material designator.
Example : SCA1-M-4N-3-S6