

## SBV60 Series High Pressure Ball Valves

### Features

- Pressure rating up to 6,000psig@70°F(21°C).
- Temperature rating from -22°F(-30°C)to 355°F(180°C) with PVDF seat or from -65°F(-54°C) to 500°F(260°C) with PEEK seat.
- Robust body is best suited for high pressure application and allows various pattern including : 2-way straight pattern, 3-way side port inlet, 3-way bottom port inlet.
- Panel mounting and locking devices are available as options.
- Blow out proof design with internally loaded stem.
- Floating ball design ensures leak proof shut-off at high pressure.
- Straight through flow path for minimum pressure drop.
- Variety of end connections include reliable S-LOK tube fittings, male/female NPT & ISO/BSP threads.
- Handle with PVC Color coated allows easy and quick operation with low torque.
- 90 degree actuation.
- Every valve is 100% factory tested with the nitrogen @1000psi (69bar).
- Optional sour gas service to NACE MR 0175.

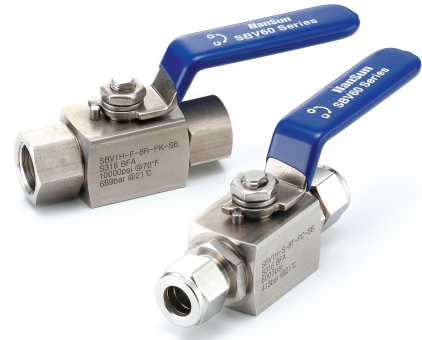

### Operation

- HANSUN SBV60 Series ball valves provide quick 1/4 turn on-off control of fluids in process, power and instrumentation applications.
- All ports are suitable as inlets in full operation pressure of the valve.
- A broad selection of valve body, seat, and seal materials provide a wide range of pressure and temperatures at which the valve may be used.
- Valves that have not been actuated for a period of time may have a higher actuation torque.

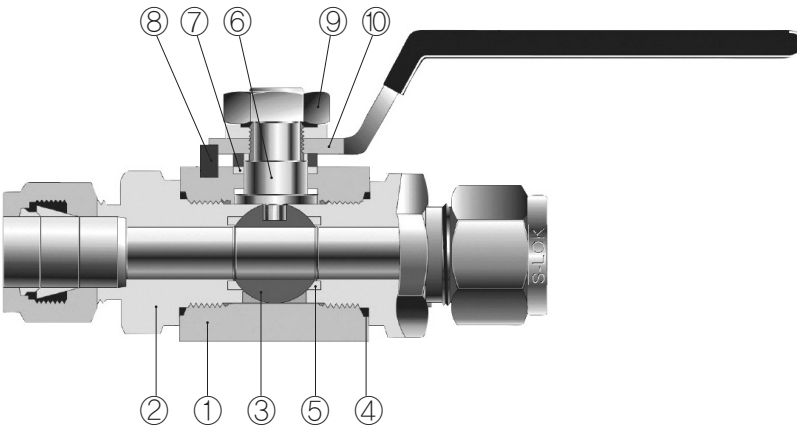

### Materials of Construction

Item	Description	Grade /ASTM Specification
1	Body	S316/A276, A479
2	End Connector	S316/A276, A479
3	Ball	S316/A276, A479
4	End Seals	Fluorocarbon FKM O-ring
5	Seats	PCTFE, optional PEEK
6	Stem	S316/A276, A479
7	Stem Packing	PTFE/D1710
8	Pin	Stainless Steel
9	Lock Nut	Stainless Steel with Washer
10	Handle	S304 with PVC Coating

※ Note : wetted parts are listed in orange color.  
Lubricant is Fluorocarbon based.

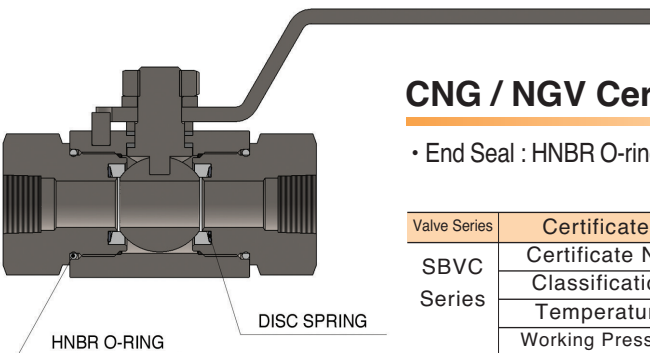

### CNG / NGV Certifications

- End Seal : HNBR O-ring
- Added DISC Spring
- Seat : PEEK

Valve Series	Certificates	ECE R110	ANSI NGV 3.1 - 2012	ISO 15500
SBV60 Series	Certificate No.	110R-010333	126840AUT14	126840MECH103
	Classification	Class 0	Manual valve	Manual valve
	Temperature	-40 to 120°C (-40 to 248°F)	-40 to 120°C (-40 to 248°F)	-40 to 120°C (-40 to 248°F)
	Working Pressure	260 bar @ 120°C	248 bar @ 120°C	260 bar @ 120°C

2-Way

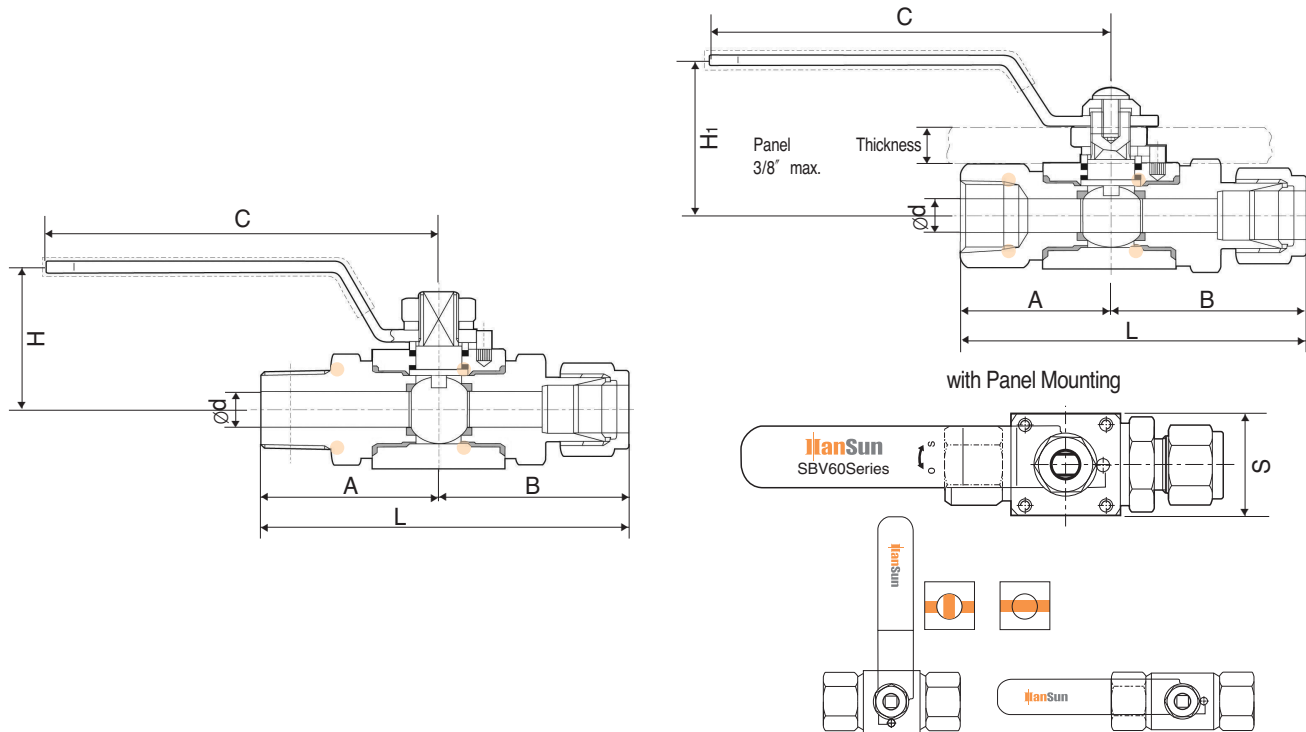

Ordering Information and Dimensions

Basic Ordering Number	Orifice mm (inch)	Cv	End Connections	d mm	Dimensions (mm)								
					A	B	L	H	H <sub>1</sub>	C	S		
SBV1H	S-4T	10.0(0.39)	1.2	1/4" S-LOK	4.8	46	46	92	39	46.7	101	32	
	S-6T		3.7	3/8" S-LOK	7.1	47.5	47.5	95					
	S-8T		7.5	1/2" S-LOK	10.0	50	50	100					
	F-4N	1/4" Female NPT		32.5		32.5	65						
	F-6N	3/8" Female NPT		38		38	76						
	F-8N	1/2" Female NPT		43		43	86						
	M-4N	3.7	1/4" Male NPT	7.1	42	42	84						
	M-6N	7.2	3/8" Male NPT	9.7	42	42	84						
	M-8N	7.5	1/2" Male NPT	10.0	47.5	47.5	95						
SBV2H	F-8N	12.7(0.50)	10.1	1/2" Female NPT	12.7	45.5	45.5	91	51	60.6	135	40	
	F-12N			3/4" Female NPT		47.5	47.5	95					
	M-12N			3/4" Male NPT		54.5	54.5	109					
	S-10T			5/8" S-LOK		55.5	55.5	111					
	S-12T			3/4" S-LOK		55.5	55.5	111					
SBV3H	F-12N	19.0(0.75)	30.0	3/4" Female NPT	20.0	48	48	96	56	65.6	135	50	
	F-16N			1" Female NPT		50	50	100					
	S-12T			3/4" S-LOK		15.8	58.5	58.5					117
	S-16T			1" S-LOK		20.0	65	65					130
	M-12N			3/4" Male NPT		15.8	58	58					116
	M-16N			1" Male NPT		20.0	62.5	62.5					125

All dimensions shown are for reference only and are subject to change. Dimensions with S-LOK nuts are in finger-tight position.

3-Way

**SIDE PORT INLET**

1/4 turn handle  
For flow switching

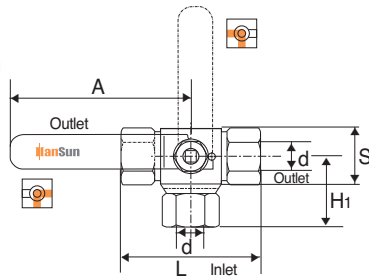

**BOTTOM PORT INLET**

1/2 turn handle  
For flow switching and isolation

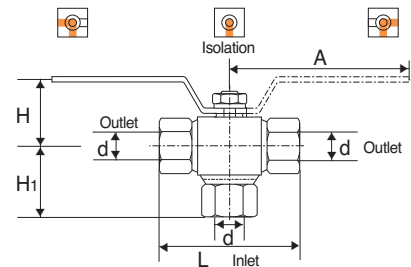

Ordering Information and Dimensions

Basic Ordering Number	End Connections Inlet & Outlet	Orifice mm (inch)	d mm	Dimensions mm				
				A	H	H1	L	S
SBV1H-3*	S-4T 1/4" S-LOK	10.0(0.39)	4.8	101	39	51.5	92	32
	S-6T 3/8" S-LOK		7.1			53.0	95	
	S-8T 1/2" S-LOK		10.0			55.8	100	
	F-4N 1/4" Female NPT		36.7			65		
	F-6N 3/8" Female NPT		40.2			72		
	F-8N 1/2" Female NPT		45.5			86		
SBV2H-3*	F-8N 1/2" Female NPT	12.7(0.50)	12.7	135	51	49.7	91	40
	F-12N 3/4" Female NPT					55.2	95	
	S-10T 5/8" S-LOK					65.5	111	
	S-12T 3/4" S-LOK					65.5	111	
SBV3H-3*	S-12T 3/4" S-LOK	19.0(0.75)	15.8	135	56	70.0	117	50
	S-16T 1" S-LOK		20.0			76.6	130	
	F-12N 3/4" Female NPT		56.7			116		
	F-16N 1" Female NPT		60.8			125		

All dimensions shown are for reference only and are subject to change. Dimensions with S-LOK nuts are in finger-tight position.  
Ordering information : \* "S" for side entry 3-way ordering i.e., SBV1H-3S-S-8T, \* "B" for bottom entry 3-way ordering i.e., SBV1H-3B-S-8T

Handle Turn torque Table (N·m)

Valve Series	Applied Working Pressures – psig(bar)						
	0(0)	69(1000)	137(2000)	206(3000)	275(4000)	344(5000)	413(6000)
SBV1H	0.30(0.22)	0.35(0.25)	0.40(0.29)	0.40(0.29)	0.40(0.29)	0.40(0.29)	0.45(0.33)
SBV2H	1.20(0.88)	1.50(1.10)	1.70(1.25)	1.70(1.25)	1.80(1.32)	1.90(1.40)	2.00(1.47)
SBV3H	1.70(1.25)	1.80(1.32)	1.90(1.40)	2.00(1.47)	2.10(1.55)	2.20(1.62)	2.30(1.69)

Technical Data-Pressure and Temperature Rating

2-way

Valve Series	Sealing Materials			Pressure Rating @ -54°C to 21°C (-65°F to 70°F)	Temperature Rating
	Seat	Stem Packing	End Seal		
SBV1H	PCTFE	PTFE	FKM	6,000psig (413bar)	-30°C to 180°C (-22°F to 355°F)
	PEEK			10,000psig (689bar)	-54°C to 230°C (-65°F to 446°F)
SBV2H	PCTFE	PTFE	FKM	5,000psig (344bar)	-23°C to 160°C (-9°F to 320°F)
SBV3H	PEEK			6,000psig (413bar)	-35°C to 210°C (-31°F to 410°F)

3-way

Valve Series	Sealing Materials			Pressure Rating @ -54°C to 21°C (-65°F to 70°F)	Temperature Rating
	Seat	Stem Packing	End Seal		
SBV1H	PCTFE	PTFE	FKM	4,000psig (275bar)	-30°C to 180°C (-22°F to 355°F)
	PEEK			6,000psig (413bar)	-54°C to 230°C (-65°F to 446°F)
SBV2H	PCTFE	PTFE	FKM	3,000psig (206bar)	-23°C to 160°C (-9°F to 320°F)
SBV3H	PEEK			4,000psig (275bar)	-35°C to 210°C (-31°F to 410°F)

- The above pressure rating is for 2-way In-line pattern valves. 80% of the above rating shall be applicable to 2-way angle pattern valves and 3-way valves.
- The rated pressure shown above is the maximum allowable pressure to the seat. If the system requires higher pressure to test, the valve must be in open position before and during test so as not to damage the seat.
- Pressure ratings of valves are sometimes limited to the maximum working pressure of pipe ends and tubing connected. The working pressure of tubing must be considered in the calculation of total system working pressure.

## Panel Mounting

### Locking nut panel mounting

Ordering designator : PN

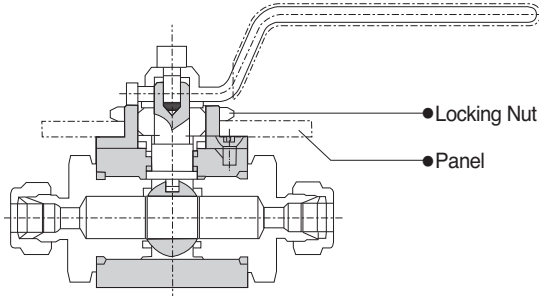

### Screw hole panel mounting

Ordering designator : PS

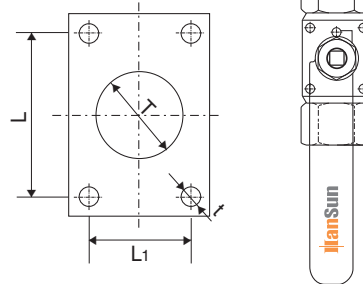

### • PN-Panel Mount Information Unit:mm(inch)

Valve Series	Panel Hole Drill	Panel Thickness
SBV1H	30.0(1.18)	Max. 4.0(0.157)
SBV2H	38.0(1.50)	Max. 4.0(0.157)
SBV3H	38.0(1.50)	Max. 4.0(0.157)

### • PS-Panel Mount Information Unit:mm(inch)

Valve Series	L	L1	t	T
SBV1H	34.0(1.33)	23.0(0.91)	4.0(0.15)	30.0(1.18)
SBV2H	36.0(1.42)	29.0(1.14)	5.0(0.20)	38.0(1.50)
SBV3H	40.0(1.57)	35.0(1.37)	6.0(0.23)	38.0(1.50)

### • Sour Gas Service

Is provided to meet NACE Standard MR 0175.

### Testing

- Every valve is factory tested for bubble-tight leakage at both seat and stem packing with nitrogen at 1000psi (69bar).
- Hydraulic shell test is performed at 1.5 times the working pressure.
- Seats have a maximum allowable leak rate of 0.1 sccm.  
optional tests are available upon request.

### • Ordering Information

Selection the applicable options from designators listed below.

SBV1H	S	4T	PK	PN	LD	OH	SG	S6
Series Designator by Orifice Size	End Connection Designator	Inlet-Outlet Size Designator	Seat Material Designator	Panel Mounting	Locking Device	Handle	Sour Gas Designator	Body Material
			• Nil : Standard PCTFE • PK : PEEK	• PN : Lock nut panel mounting • PS : Screw hole panel mounting	• LD : Locking Device	• Nil : Standard lever handle • OH: Oval Handle (Applicable only for SBV1H)	• Nil : Without(Standard) • SG: Sour Gas Service	• S6 : 316 Stainless Steel

### ※ CNG / NGV Service

- To order CNG / NGV Service, insert the designator "C" to the valve ordering number.
- Material's PEEK standard.  
ex) SBVC1H-S-4T-S6

### SAFETY in VALVE SELECTION

When selecting a valve, the total system design must be considered to ensure safe, trouble-free performance. Valve function, materials compatibility, adequate ratings, proper installation, operation, and maintenance are the responsibility of the system designer and user.