

## MARINE STEAM-IT ELECTRIC PRESSURE COOKER



- SB-ST-E (Three pan electric marine pressure cooker, NSN approval number NSN 7310-01-102-2673)

### OPERATION SHALL BE BY:

Electrically operated Steam-It which shall be rated at 12KW and shall be equipped for operation at:

- 440-480 VAC, 3 Phase (Standard)

Cooking compartment shall have a capacity of:

- (3) 12" x 20" x 2 1/2" Pans  
 (2) 12" x 20" x 4" Pans

### Standard Features

- (4) Flanged Feet
- Spray Hose
- (6) 12 x 20 x 2-1/2" Perforated Pans

### Shipping Weight

- 175 lbs (79 kg)

### OPTIONS & ACCESSORIES AT ADDITIONAL COST

#### Pans & Covers

- |  |  |  |
|--|--|--|
| <input type="checkbox"/> 12" x 20" pan cover           | <input type="checkbox"/> 12" x 20" x 2-1/2" solid pan      | <input type="checkbox"/> 12" x 20" x 6" solid pan      |
| <input type="checkbox"/> 12" x 20" x 1" solid pan      | <input type="checkbox"/> 12" x 20" x 2-1/2" perforated pan | <input type="checkbox"/> 12" x 20" x 6" perforated pan |
| <input type="checkbox"/> 12" x 20" x 1" perforated pan | <input type="checkbox"/> 12" x 20" x 4" solid pan          |  |
|  | <input type="checkbox"/> 12" x 20" x 4" perforated pan     |  |

### STANDARD CONSTRUCTION SPECIFICATIONS

Shall be a Market Forge Counter Model SB-ST-E Marine Electrically Operated Steam-It, 15 PSI 1.1kg/cm<sup>2</sup> Pressure Cooker on adjustable flanged feet.

Steam-It shall have a 3/16" 5mm aluminum welded seamless cooking compartment.

Exterior finish shall be stainless steel.

Door shall be self-sealing inside type which cannot be opened under pressure, 12 gauge stainless steel, removable for cleaning without tools.

Door gasket shall be one piece molded, replaceable without tools or cement.

Unit cooking cycle shall be automatically controlled, requiring only the setting of 0-60 minute timer and the insertion of 5 qts. 4.7 liters of water into the cylinder.

At the end of the cooking cycle, steam shall be exhausted from cooking compartment and a continuous audible signal shall sound.

Unit shall include safety valve, a steam pressure gauge, exhaust valve silencer, low water cut-off, rinse and fill hose and drain connection, and shall be completely serviceable from the front.



Approval Notes: \_\_\_\_\_

\_\_\_\_\_

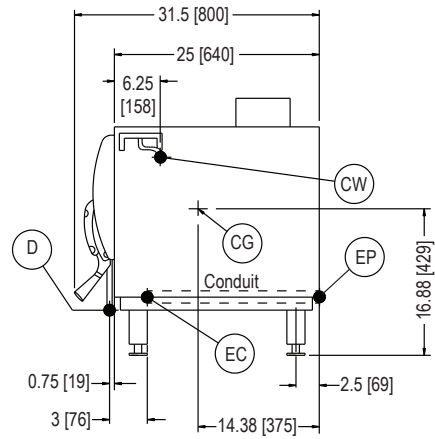
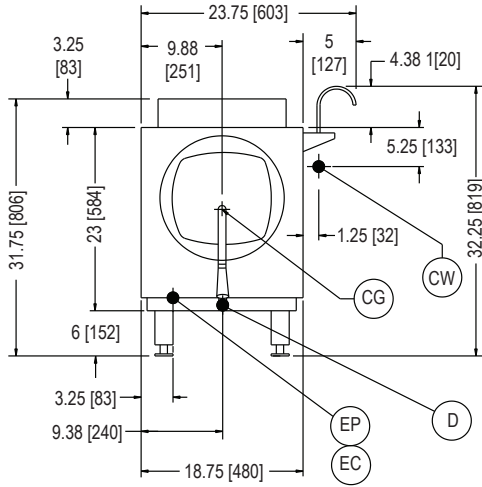

DIMENSIONS ARE IN INCHES [MM]

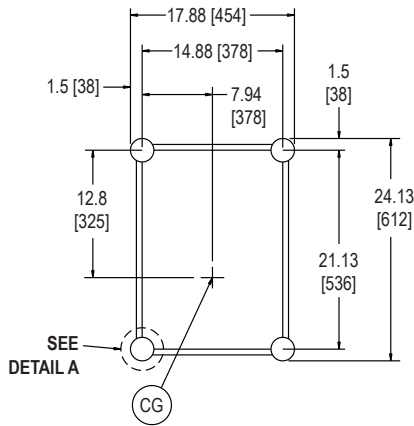

BOTTOM VIEW

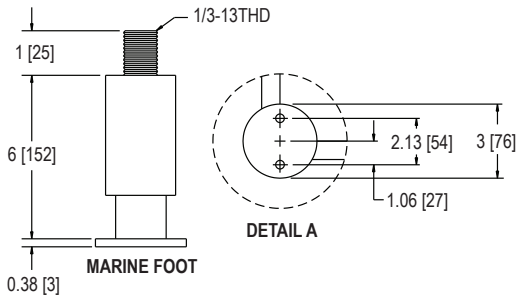

**SERVICE CONNECTIONS**

SYMBOL	DESCRIPTION
EC	Electrical Connection - Connection for incoming power supply wires on terminal block
EP	Power Supply - 1-1/4" threaded access hole for power supply wires. Use wire suitable for at least 90°C. Nominal amps per line.
D	Drain - 1/2" 13mm O.D. tubing. Air break required for drain connection supplied by others
CW	Cold Water - 3/8" 10mm O.D. tubing connection to fill hose. Cold water line shall have a max of 50 PSI 3.5kg/cm2 and a min of 25 PSI 1.7kg/cm2 water pressure
CG	Center of Gravity - with flanged feet

The manufacturer reserves the right to modify materials and specifications without notice.

**WATER SUPPLY AND DRAIN SPECIFICATIONS**

Good quality water feed is the responsibility of the owner. Water quality must be within the following general guidelines.

TDS: 40-125 ppm    Hardness: 35-100 ppm    pH: 7.0 - 8.5    Silica: <13 ppm    Chlorides: <25 ppm    Chlorine: <0.2 ppm    Chloramine: <0.2 ppm

The best defense against poor water quality is a water treatment system designed to meet your water quality conditions.

Appliance to be installed with backflow protection according to federal, state or local codes.

**DISCLAIMER**

**Terry System Cartridge Changes / Installation** – "2-3 gallons of water **MUST** be purged at each cartridge change or new installation prior to water supply being fed to the steamer. Failure to do so can result in component damage within the steamer which is not covered under warranty. For additional guidance on proper installation, refer to install documentation provided with each Terry System and Replacement Cartridge Set."

**INTENDED FOR COMMERCIAL USE ONLY.  
NOT FOR HOUSEHOLD USE.**

