

**I**

# INDIRECT FIRED CK CONVECTION OVEN

JOB NAME: \_\_\_\_\_

ITEM NO.: \_\_\_\_\_

NO. REQUIRED: \_\_\_\_\_

## MODEL

- CKOVEN - Full size indirect fired convection oven (intended to be used with an external heat source that is not supplied)

## DESCRIPTION

- INDIRECT FIRED - does not allow harmful flue gases into the oven cooking cavity
- SMALL FOOTPRINT - 36" Wide x 35" front to back
- TWO SPEED MOTOR - High Speed, 1650 RPM / low speed, 1375 RPM
- MULTIPLE COOK TIMERS - (1) 5 hour timer and (1) 60 minute timer
- INDEPENDENT SOLID DOORS - Allows motor to cool down oven with one door open - could also serve as a secondary heat source when the oven doors are left open
- FULL SIZE OVEN - Capacity allows for (5) full size sheet pans
- COOKING CAVITY - Has coved corners for ease of cleaning
- STAINLESS STEEL CONSTRUCTION - Interior & exterior

## ELECTRICAL CHARACTERISTICS

- 120 VAC, 60 Hz, 1 phase, 3.2 amps

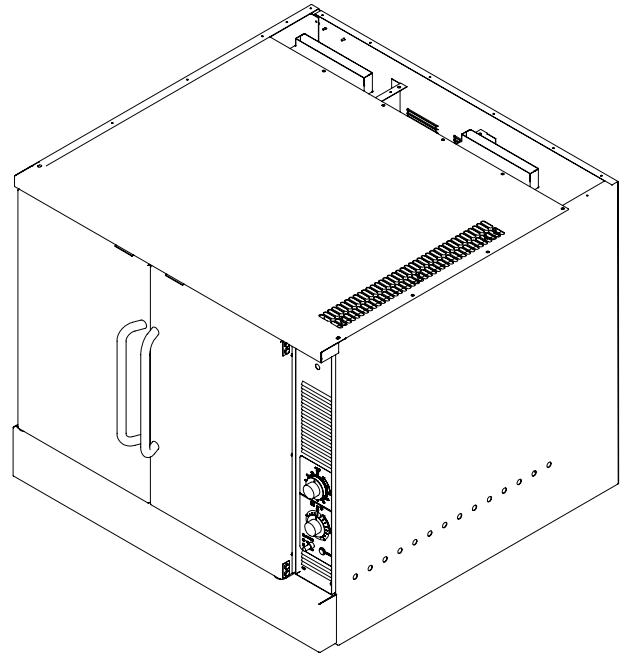
**FOOD SERVICE EQUIPMENT**  
 Indirect Fired Convection Oven

DIMENSIONS ARE IN INCHES [MM]

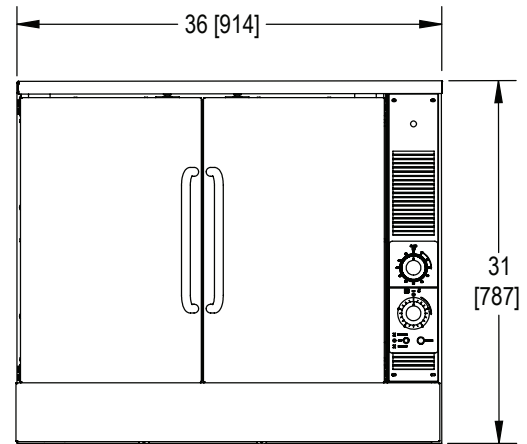
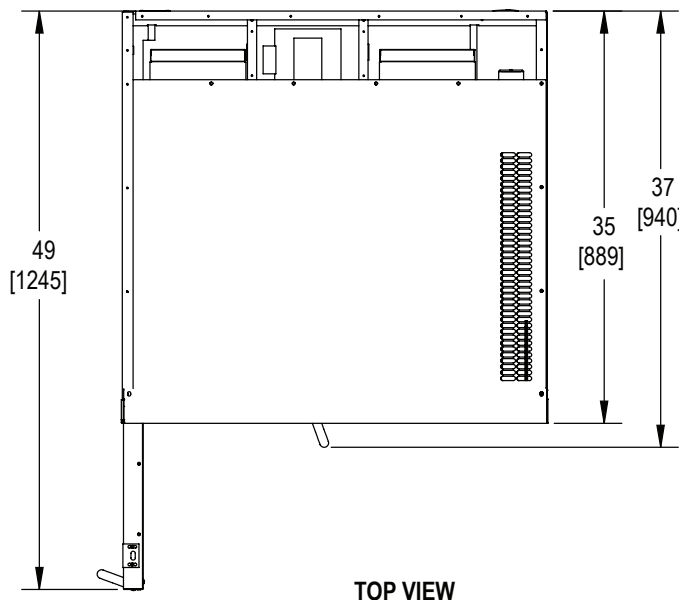

The manufacturer reserves the right to modify materials and specifications without notice.