



BEVERAGE-AIR

Project: _____	AIA#
Item: _____	
Location: _____	SIS#
Approved: _____	

VISTA® BOTTOM MOUNT REACH-IN FREEZER

FB44HC Solid Door Reach-in Freezer
Hydrocarbon Series

MODEL:
FB44HC-1S

FB44HC BOTTOM MOUNT MODELS: VISTA® SERIES

3 Year Parts/Labor Warranty
Additional 4 Year Compressor Warranty

CABINET CONSTRUCTION

- Stainless steel front and doors, gray painted sides
- Gray painted aluminum interior
- Full electronic control
- LED lighting standard
- Anti-microbial door handles
- Door locks, standard
- Self-closing doors with 120° Stay-open feature, on spring-loaded hinges
- Door locks (solid doors only)
- One-piece grille allow easy removal/installation for preventative maintenance
- Three (3) heavy duty epoxy coated wire shelves per door section
- 6" Caster standard with (2) brakes



OPTIONS & ACCESSORIES

- Stainless steel universal tray slide (AC)
- Additional epoxy shelves
- Shelf clips
- 3" caster or 6" legs
- Remote option* (see note on back page)

REFRIGERATION SYSTEM

- Uses environmentally friendly, energy efficient R290 refrigerant, and meets all regulatory requirements for CARB, SNAP, DOE & more
- Hot gas condensate evaporator
- Adaptive defrost
- Epoxy coated evaporator coil
- Maintains product temperatures of 0° F and below



Please verify qualifying units by visiting:
www.energystar.gov/cfs

3779 Champion Blvd., Winston-Salem, NC 27105
1-888-845-9800 Fax: 1-336-245-6453
Beverage-Air.com Sales@bevair.com



BEVERAGE-AIR

MODEL	FB44HC-1S
EXTERNAL DIMENSIONAL DATA	
Width Overall	47"
Depth Overall with Handle	33 3/4"
Height Overall with 6" casters	84 1/4"
Number of Doors	2
Depth with Door Open 90°	53 5/8"
Door Opening	19 3/4" x 51 7/8"
INTERNAL DIMENSIONAL DATA	
NET Capacity (cubic ft.)	44
Internal Width Overall (in)	44"
Internal Depth Overall (in)	25 7/8"
Internal Height Overall (in)	61 5/8"
Internal Height Useable (in)	53"
Number of Shelves	6
ELECTRICAL DATA	
Full Load Amperes 115/60/1	11.0
REFRIGERATION DATA	
Horsepower	3/4
Capacity (BTU/Hr)*	2312
SHIPPING DATA	
Gross Weight - Crated	562 lbs
Height - Crated	85"
Width - Crated	49"
Depth - Crated	36"

*NOTE: Remote units are field wired and come with 6" legs. Refrigerant must be specified at time of order.

Bottom Mount Reach-in Freezer

Model: FB44HC-1S

Model Views

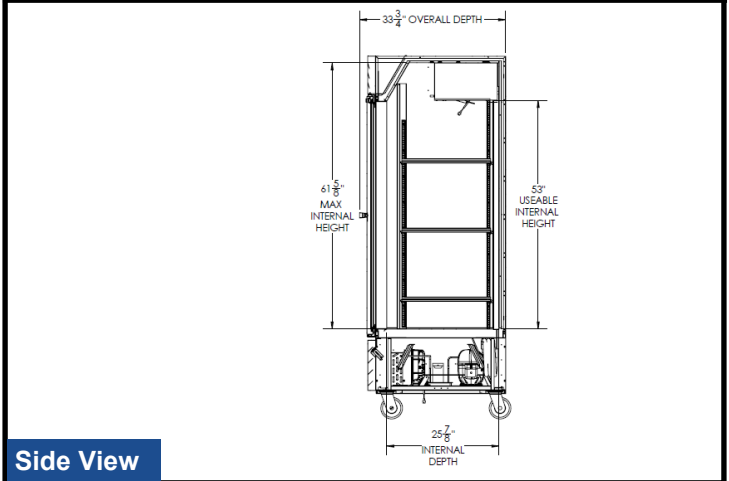
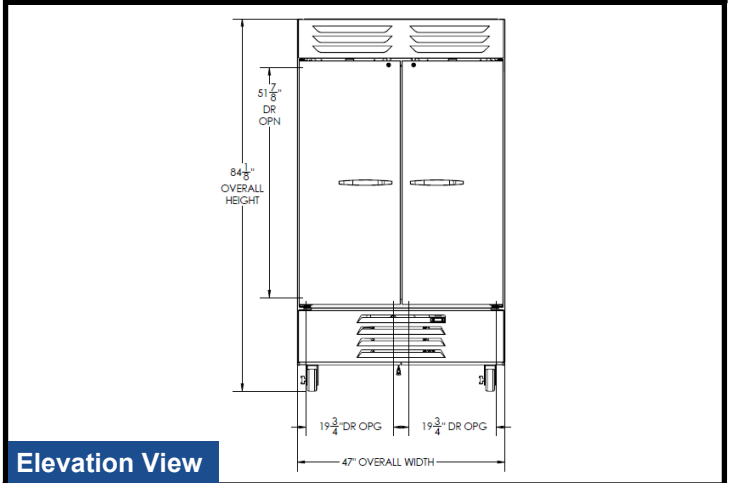
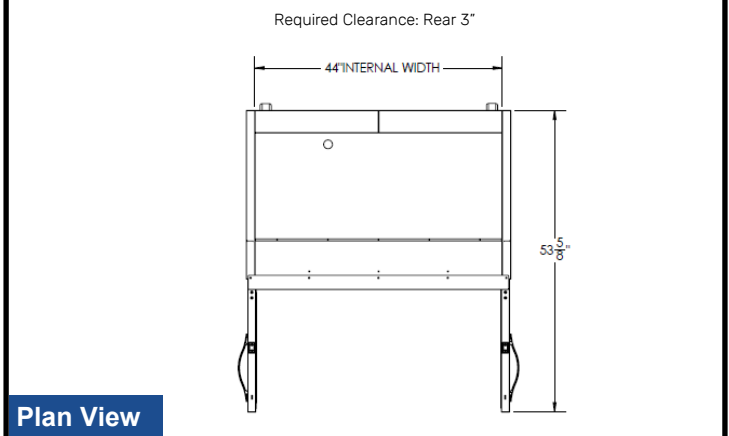

ELECTRICAL CONNECTION



115/60/1
NEMA-5-15P

Units pre-wired at factory and include 8' long cord and plug set.



3779 Champion Blvd., Winston-Salem, NC 27105 1-888-845-9800 Fax: 1-336-245-6453 Beverage-Air.com Sales@beair.com

an Ali Group Company



The Spirit of Excellence